

DIGITAL PROPORTIONAL VALVE CONTROLLER OPERATING INSTRUCTION

SY-DPCA-C-1 : Case with DIN-35 Rail Clamps SY-DPCA-P-1 : PCB Only

MODEL SPEC.

Model	SY-DPCA-C-1, SY-DPCA-P-1
Operating Voltage	9 ~ 32VDC
Voltage Tolerance	5%
Input Signal Options	0~5V, 0~10V, 4~20mA, RS485
Output Current	3A max.
Dither Frequency	70 ~ 350Hz

Model	SY-DPCA-C-1, SY-DPCA-P-1
Ramp Up and Down	0.1 ~ 5.0s
Reference Voltage	5V (max. current 5mA)
Communication Interface	RS485
Communication Protocol	Modbus RTU
Operating Conditions	-20 ~ 60°C

CONNECTIONS AND DIMENSIONS

Wiring Instruction

1	VS-	Power-
2	VS+	Power+
3	Out+	Coil+
4	Out-	Coil-
5	Vi+	Input voltage signal
6	Vi- li-	Signal ground
7	li+	Input current signal
8	Enable	Enable *
9	Vref +5V	+5V reference voltage
10	D+	RS485+ (optional)
11	D-	RS485- (optional)

* Default off. Ground this pin to enable controller when PEA function is on.

► SY-DPCA-P-1

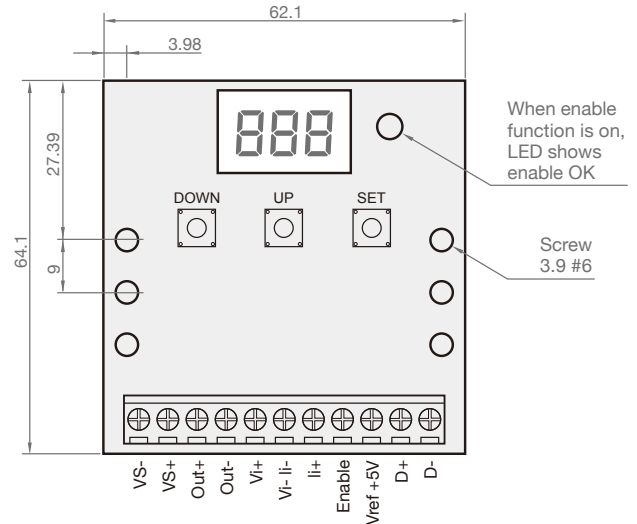

► SY-DPCA-C-1

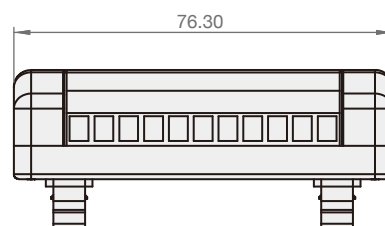
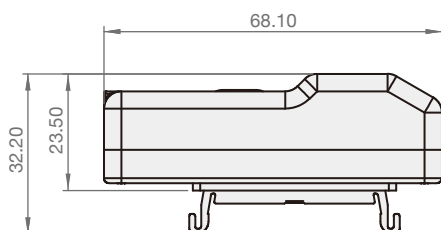
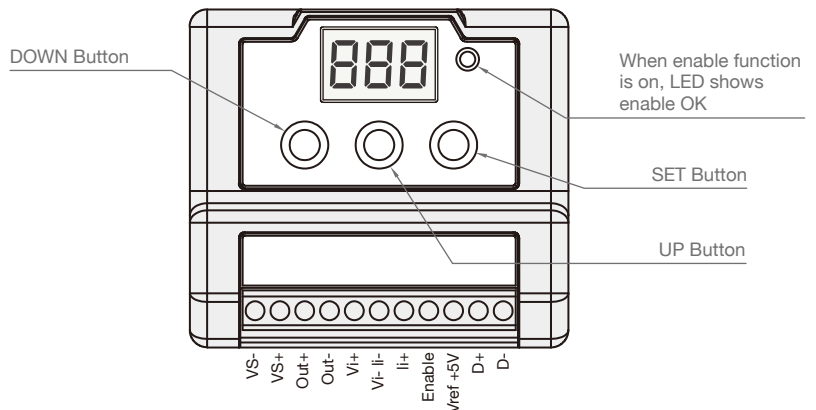
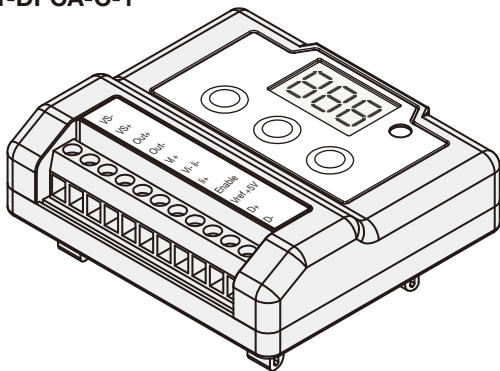

(Unit : mm)

SETTING THE PARAMETERS

- At main screen, push **SET** button for 2s and open function menu.
- At function menu, push **UP** and **DOWN** to select function.
- Push **SET** button to open function value and push **UP** and **DOWN** to adjust it.
- After adjustment, push **SET** button to setup function value and return to function menu.
- Return to main screen by pushing **SET** button for 2s manually or idling for 60s.
- Save setup: select *P5R* function and adjust its value to "5". If no saving all the function value will be reset after reboot.
- Default setup: select *P r F* function and adjust its value to "5".

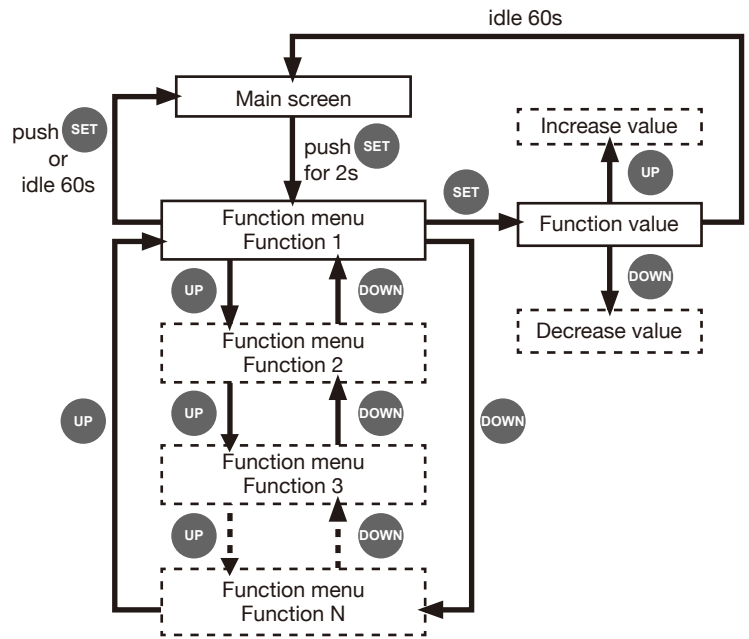

FUNCTION TABLE

No.	Function	Display	Default Value	Adjustment Range	Unit	Description
1	Max. output current	<i>P IH</i>	1.00	0.20~3.00	A	adj. unit 0.01A
2	Min. output current	<i>P IL</i>	0.00	0.00 ~ 1.00	A	adj. unit 0.01A
3	Ramp up time	<i>P r U</i>	0.1	0.1 ~ 5.0	s	adj. unit 0.1s
4	Ramp down time	<i>P r d</i>	0.1	0.1 ~ 5.0	s	adj. unit 0.1s
5	Enable	<i>P E R</i>	0	0 ~ 1		0: function off 1: function on, ground the ENABLE pin to enable controller
6	Input signal type	<i>P R I</i>	10	10/5/420/ 485/PCt		10:0-10V ; 5:0-5V ; 420:4~20mA ; 485:485 control ; PCt:panel control
7	Dither frequency	<i>P d F</i>	140	70 ~ 350	Hz	adj. unit 10Hz
8	Command deadband	<i>P c d</i>	2	0 ~ 5	%	adj. unit 1%
9	Display type	<i>P d S</i>	0	0 ~ 2		0: output current (A) 1: input instruction (V or mA) 2: display off for power saving
10	Save setup	<i>P S R</i>	0	0 ~ 5		When the value = 5, save the parameters instruction
11	Default setup	<i>P r F</i>	0	0 ~ 5		When the value = 5, restore factory setting
12	Clear error code	<i>P c L</i>	0	0 ~ 5		When the value = 5, delete the error code of current overload
13	Device address	<i>A d r</i>	001	001~247		*1
14	Baud rate	<i>b d r</i>	19.2	4.8/9.6/19.2/ 38.4/57.6	K	*1

*1. Modbus user manual and PC software could be downloaded in below link :

FUNCTION CHART

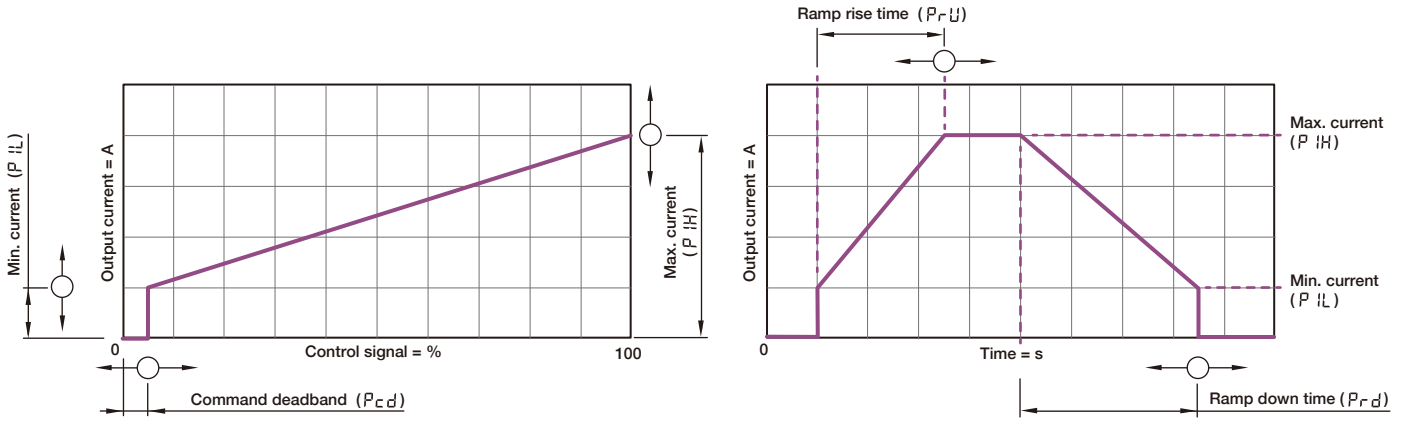

WIRING EXAMPLE

1. Potentiometer control via built-in 5Vref

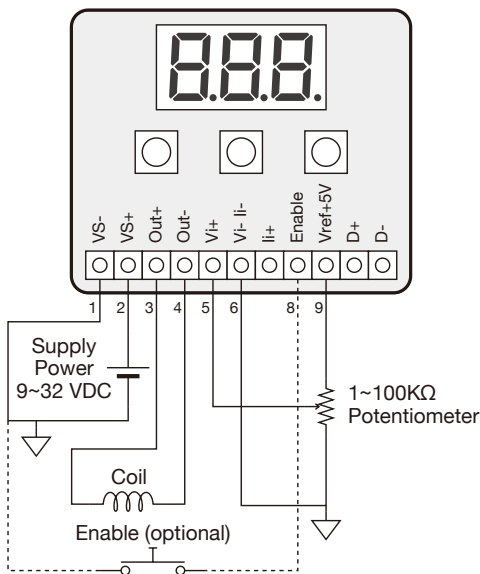

* Adjust PR 1 function value as "5".

2. External command control

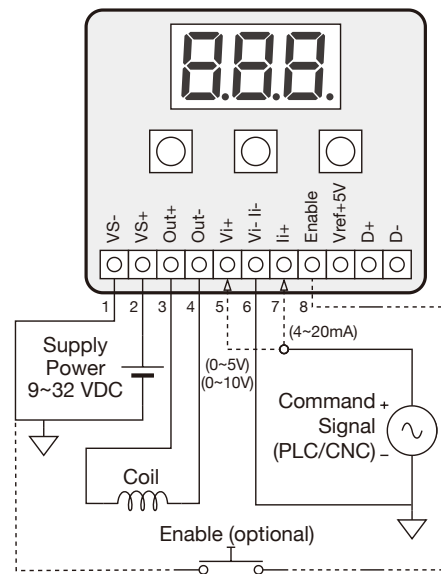

* Adjust PR 1 function value according to the signal source.

3. Modbus control via RS485

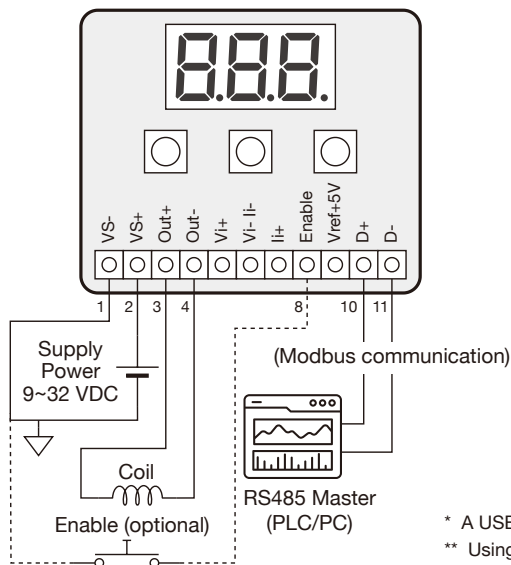

* A USB-RS485 converter (Purchase separately) is necessary to connect PC.

** Using a USB-RS485 converter, you can operate and configure parameters via the PC software provided by our company. Please mail us to get the PC software : info@steadmachinery.com.tw.



ERROR CODE

Error Code	Error Description	Clear Error Code
E 10	4-20mA signal open	For error code E 10, E 11, E 30, controller will detect troubleshooting and clear the error code automatically.
E 11	4-20mA signal overload	
E 30	Coil open	For error code E 31, after troubleshooting, it is necessary to adjust function P c L or reboot to clear the error code.
E 31	Coil short	

WARNING

1. Install the controller and Coil only when the power is off.
2. According to European standards EN-982, the electrical output signal of the controller (e.g. reference voltage) must not be directly used to activate safety functions, like to switch-ON/OFF the machine's safety components.



This product has been designed and tested to meet specific standards outlined in the European Electromagnetic Compatibility Directive (EMC)2014/30/EU.

Emission: EN 61000-6-4:2019

Immunity: EN 61000-6-2:2019; EN 61000-4-2:2009, EN 61000-4-3:2020, EN 61000-4-8:2010

Certificate No. NE1105240044

COMMUNICATION PARAMETERS

The default Modbus RS485 communication parameters are as follows (some can be adjusted via the control panel) :

Parameter	Settings	Remarks
Device Address	1(01h) ~ 247(F7h)	Default : 1
Baud Rate	4800, 9600, 19200, 38400, 57600	Default : 19200
Data Bits	8	Fixed
Parity	None (N)	Fixed
Stop Bits	1	Fixed
Protocol Mode	RTU	Fixed
Supported Function codes	03h (Read), 06h (Write)	Others not supported

REGISTER ADDRESS TABLE

The following Modbus registers are supported :

Register Address	Name	R/W	Description	Example	
				Decimal	HEX
0000H	Output Current	R	Unit: 0.01A (e.g., 67 → 0.67A)	67	0043h
0001H	Input Signal	R	Unit: 0.1% (e.g., 356 → 35.6%)	356	0164h
0002H	Device Status	R	0: Normal; 1: Current Signal Broken; 2: Overload; 3: Coil Open; 4: Coil Short	0	0000h
0003H	Signal Selection	R/W	0:0~10V (Default); 1:0~5V; 2:4~20mA; 3:RS485; 4: Panel Control	2	0002h
0004H	Enable Mode	R/W	0: Disabled (Default); 1: Enabled	0	0000h
0005H	Display Mode	R/W	0: Show Current (Default); 1: Show Input Signal; 2: No Display	0	0000h
0006H	485 Control Signal	R/W	0~100%, Unit: 1% (e.g., 80 → 80%)	80	0050h
0007H	Factory Reset	R/W	Write 5 to reset addresses 0003H~000DH to default values (Device Address and Baud Rate will be reset)	5	0005h
0008H	Max Current Setting	R/W	0~3.00A, Unit: 0.01A (e.g., 300 → 3.00A)	300	012Ch
0009H	Min Current Setting	R/W	0~1.00A, Unit: 0.01A (e.g., 100 → 1.00A)	100	0064h
000AH	Current Rise Time	R/W	0.1~5.0s, Unit: 0.1s (e.g., 50 → 5.0s)	50	0032h
000BH	Current Fall Time	R/W	0.1~5.0s, Unit: 0.1s (e.g., 10 → 1.0s)	10	000Ah
000CH	Dither Frequency	R/W	70~350Hz, Unit: 10Hz (e.g., 35 → 350Hz)	35	0023h
000DH	Dead Zone Setting	R/W	0~5%, Unit: 1% (e.g., 5 → 5%)	5	0005h

ERROR HANDLING

If an error occurs, the controller responds with:

1. Error Types:

- Unsupported function code (e.g., 04h)
- Invalid register address (e.g., 000EH out of range)
- Data value out of range (e.g., writing 400 to 0008H)
- For other errors such as CRC or frame length errors, controller will discard the message without responding.

2. Error Response Format:

- Original function code **+128 (80h)**
- Error code: **01h** (indicates the error type)

3. Example:

- Host request 01 04 0008 0001 (invalid function code 04h)
- Controller response 01 84 01 (84h = 80h + 04h, 01h = error code)

COMMUNICATION EXAMPLES

Example 1: Reading Data

Read "Output Current (0000H)" and "Input Signal (0001H)" from device address 01h.

Host Request

01 03 0000 0002 C40B

- 01: Device address
- 03: Function code (Read)
- 0000: Start address (0000H)
- 0002: Read 2 registers
- C40B: CRC checksum

Controller Response

01 03 04 006E 0212 1A83

- 01: Device address
- 03: Function code (Read)
- 04: Byte count (4 bytes)
- 006E: 0000H value (0x006E = 110 → 1.10A)
- 0212: 0001H value (0x0212 = 530 → 53.0%)
- 1A83: CRC checksum

Example 2: Writing Data

Set "Vibration Frequency (000CH)" to 250Hz for device address 0Eh.

Host Request

0E 06 000C 0019 88FC

- 0E: Device address
- 06: Function code (Write)
- 000C: Target address (0000H)
- 0019: Value (0x0019 = 25 → 250Hz)
- 88FC: CRC checksum

Controller Response

01 03 04 006E 0212 1A83

- Echoes the request to confirm successful write.

PC COMMUNICATION SOFTWARE

Using a USB-RS485 converter, you can operate and configure parameters via the PC software provided by our company.

Installation Guide

- Step 1 : Insert the converter into the USB port on the PC.
- Step 2 : Install the converter driver (only required for the first use).
- Step 3 : Connect the controller and the converter.
- Step 4 : Launch the PC software. Please mail us : info@steedmachinery.com.tw.
- Step 5 : Follow the instructions within the software to proceed.



NOTES

1. **Timeout** : Ensure **>10ms** idle time between messages.
2. **CRC Checksum** : Mandatory for all messages (use standard Modbus RTU CRC calculation).
3. **Address Range** : Only 0000H~000DH registers are valid.
4. All parameters configured through Modbus will be saved automatically.