

Cartridge Valve

- Solenoid Operated
- Pressure Control
- Flow Control
- Directional
- Load Holding
- Logic Element
- Circuit Saver
- Electronic Amplifier P-C Board
- Filter
- Cavity Plug



Contents

Operating Recommendation	7
Index	8
Solenoid Operated	
Solenoid-Operated, 2-posion 2-way, Poppet Valve	DTA 22
Solenoid-Operated, 2-posion 3-way, 1 to 2, Shift to 2 to 3, Poppet Valve DWA 24
Solenoid-Operated, 2-posion 2-way, Spool Valve	DLA 26
Solenoid-Operated, 2-posion 3-way, Spool Valve	DMA 28
Pressure Control	
Pilot Stage, Proportional, Relief	RBP 30
Pilot Stage, Proportional, Inverse Relief	RBN 32
Pilot Stage, Direct-acting Relief Valve - Pilot Capacity	RBC, RBA .. 34
Main Stage, Pilot Operated Relief with Integral T8A Cavity	RPC8 36
Pilot Operated Relief Valve	RPC 38
Fast-acting, Pilot Operated Relief	RPE 40
Direct-acting Relief Valve	RD 42
Kick-down, Pilot-operated, Balanced Piston Relief Valve	RQ 44
Pilot Operated Relief Valve with Vent	RVA 46
Ventable, Pilot-operated, Balanced Piston Relief Valve with Drain to Port 4 RVD 48
Pilot Operated Sequence Valve	RS 50
Kick-down, Pilot-operated, Balanced Piston Sequence Valve	SQ 52
Direct-acting Sequence Valve with Reverse Flow Check	SC 54
Direct-acting Sequence Valve without Reverse Flow Check	SX 56
Pilot Operated Reducing Valve	PB 58
Proportional, Direct Acting Pressure Reducing / Relieving, Low Leakage PRP 60
Proportional, Direct Acting Pressure Reducing / Relieving, Better Dynamic Response PRL 62
Pilot Operated Reducing / Relieving Valve	PP 64
Direct-acting Pressure Reducing / Relieving Valve	PRB 66
Flow Control	
Proportional, Normally Closed, Flow Control Valve	FPC 68
Proportional, Normally Open, Flow Control Valve	FPH 70
Proportional, 3-way, Flow Control Valve	FMA 72
Fully Adjustable Needle Valve	NFC 74
Fully Adjustable and High Capacity Needle Valve	NFD 76
Fully Adjustable Needle Valve (with Free Flow Check Valve)	NCB 78

(continue)

Pressure Compensated Fully Adjustable Flow Control Valve (with Free Flow Check Valve)	FD	80
Normally Closed, Modulating Element with Pilot Source from Port 1 ..	LRA	82
Normally Closed, Modulating Element	LRC	84
Directional		
Pilot-to-Open Check Valve with Standard Pilot & POM Seat.....	CKA	86
Pilot-to-Open Check Valve with Standard Pilot	CKB	88
Pilot-to-Open Check Valve with Sealed Pilot & POM Seat	CKC	90
Pilot-to-Open Check Valve with Sealed Pilot	CKD	92
Vented, Pilot-to-Open Check Valve with External Pilot Port	CKF	94
Vented, Pilot-to-Open Check Valve	CVV	96
Shuttle Valve	CSD, CSB ...	98
Shuttle Valve, with External Port	CSA, CSC	100
Check Valve, Free Flow Port1 to Port2	CXA	102
Check Valve, Free Flow Port2 to Port1 with POM Seat	CXB	104
Check Valve, Free Flow Port2 to Port1	CXD	106
Load Holding		
3:1 Pilot Ratio, Vented Counterbalance Valve - Atmospherically Referenced	CAA	108
5:1 Pilot Ratio, Vented Counterbalance Valve - Atmospherically Referenced	CAG	110
Counterbalance 3:1 Pilot Ratio External Pilot Non-Vented Valve	CBA	112
Counterbalance 4.5:1 Pilot Ratio External Pilot Non-Vented Valve	CBG	114
Counterbalance 10:1 Pilot Ratio External Pilot Non-Vented Valve	CBH	116
3:1 Pilot Ratio, Semi-restrictive Counterbalance Valve	CBC	118
4.5:1 Pilot Ratio, Semi-restrictive Counterbalance Valve	CBD	120
3:1 Pilot Ratio, Restrictive Counterbalance Valve	CBE	122
4.5:1 Pilot Ratio, Restrictive Counterbalance Valve	CBF	124
3:1 Pilot Ratio, Vented, Counterbalance Valve	CWA	126
5:1 Pilot Ratio, Vented, Counterbalance Valve	CWG	128
Logic Element		
Logic Elements.....	LO	130
Normally Open, Logic Modulating	LP	132
Circuit Saver		
Fixed Orifice, Flow Fuse Valve	FQ	134
1.8:1 Pilot Ratio, Pilot to Close Check Valve	COA	136
120:1 Pilot Ratio, Pilot to Close Check Valve	COO	138

(continue)

30%, Accumulator Sense, Pump Unload Valve with Check - Pilot Capacity	QC	140
Cavity Plug		
2 Holes External Port Blocked Cavity Plug	OA2	142
2 Holes All Ports Blocked Cavity Plug	CA2	143
Port 1 to 2 Open, Port 3 Blocked Cavity Plug	OA3	144
3 Holes All Ports Blocked Cavity Plug	CA3	145
Electronic Amplifier P-C Board		
Digital Proportional Controller - Case	SY-DPCA-C-1	146
Digital Proportional Controller - PCB Only	SY-DPCA-P-1	148
Dual Output Proportional Controller	SY-DPCA-C-2	150
Digital Proportional Controller - DIN Plug	SY-DPCA-D-P9-1	152
Filter		
.....	FLA	153
SAE Cavity Cartridge Valve > Pressure Control		
Noiseless Direct Acting Diagonal Area Relief Valve	MH	158
SAE Cavity Cartridge Valve > Flow Control		
Check with Manual Flow Adjustment	CN	160
Fully Adjustable Needle	NV	162
Fully Adjustable Needle with Free Flow Check	NC	164
Flow Divider (Flow Ratio: 1:1)	CP	166
SAE Cavity Cartridge Valve > Directional		
Check Free Flow 1-2, Poppet Type	CV	168
Shuttle Valve	LS	170
SAE Cavity Cartridge Valve > Directional > On/Off Valves 2 Way Valve		
Normally Closed Single Check	HS, JS, LS, PS-2A	172
Normally Closed Single Check Reverse Flow	HS, JS, LS, PS-2B	174
Normally Open Single Check	HS, JS, LS, PS-2C	176
Normally Open Single Check Reverse Flow	HS, JS, LS, PS-2D	178
Normally Closed Double Check	HS, JS, LS, PS-2I	180
Normally Open Double Check	HS, JS, LS, PS-2J	182
SAE Cavity Cartridge Valve > Directional > On/Off Valves 3 Way Valve		
3 Way, 2 Position	HS-3A, JS-3A	184
3 Way, 2 Position	HS-3X, JS-3X	186
Cavities Tooling		
Cavities Tooling (SAE Cavity)		
		188
		192

Operating Recommendation

· **Fluid Viscosity Recommendations**

15 to 380 cSt

· **Fluid Cleanliness Recommendations**

Specified in accordance with ISO 4406:1999; 4µm / 6µm / 14µm

· **Fluid Temperature Recommendations**

Buna N (Nitrile) : -35°C to 90°C

Viton : -20°C to 120°C

CONTROL MANNER

► **L : Standard Screw Adjustment**

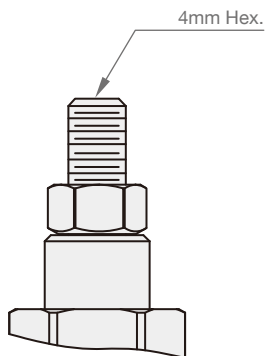

► **K : Hand Knob with Lock Knob**

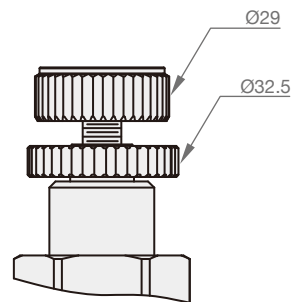

► **C : Tamper Resistant Cover**

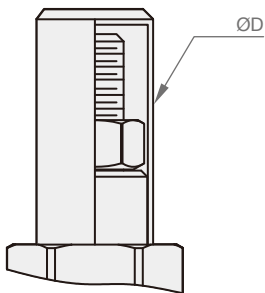

For Line Mount Type

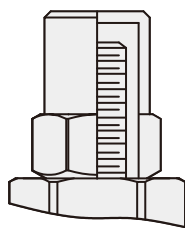

For SAE Cavity Type

ØD	Size	Cavity
Ø19	02	T10, T11, T13
Ø25	03	T2, T3, T5
Ø30	06	T16, T17
Ø40	08	T18, T19

Index

Solenoid Operated

Page No.	Function	Symbols	Model No.	Cavity	Capacity (l/min)	Control Manner			
						L	K	X	M
22	Solenoid-Operated, 2-position 2-way, Poppet Valve		DT2A	T13A	40				✓
24	Solenoid-Operated, 2-position 3-way, 1 to 2, Shift to 2 to 3, Poppet Valve		DW2A	T11A	30				✓
26	Solenoid-Operated, 2-position 2-way, Spool Valve		DL2A	T13A	45				✓
28	Solenoid-Operated, 2-position 3-way, Spool Valve		DM2A	T11A	45				✓

Pressure Control

Page No.	Function	Symbols	Model No.	Cavity	Capacity (l/min)	Control Manner			
						L	K	X	M
30	Pilot Stage, Proportional, Relief		RB1P	T8A	1				✓
32	Pilot Stage, Proportional, Inverse Relief		RB1N	T8A	1				✓

Page No.	Function	Symbols	Model No.	Cavity	Capacity (l/min)	Control Manner		
						L	K	X
34	Pilot Stage, Direct-acting Relief Valve - Pilot Capacity		RB2C	T10A	1	✓	✓	
			RB3A	T3A	2	✓	✓	
36	Main Stage, Pilot Operated Relief with Integral T8A Cavity		RP2C8	T10A	95			
			RP3C8	T3A	200			
			RP6C8	T16A	380			
			RP8C8	T18A	760			
38	Pilot Operated Relief Valve		RP2C	T10A	95	✓	✓	
			RP3C	T3A	200	✓	✓	
			RP6C	T16A	380	✓	✓	
			RP8C	T18A	760	✓	✓	
40	Fast-acting, Pilot Operated Relief		RP2E	T10A	95	✓	✓	
			RP3E	T3A	200	✓	✓	
			RP6E	T16A	380	✓	✓	
			RP8E	T18A	760	✓	✓	
42	Direct-acting Relief Valve		RD1A	T162A	28.4	✓		
			RD2A	T10A	95	✓		
			RD3A	T3A	200	✓		
			RD6A	T16A	380	✓		
44	Kick-down, Pilot-operated, Balanced Piston Relief Valve		RD8A	T18A	760	✓		
			RQ2B	T10A	95	✓	✓	
			RQ3B	T3A	200	✓	✓	
			RQ6B	T16A	380	✓	✓	
46	Pilot Operated Relief Valve with Vent		RQ8B	T18A	760	✓	✓	
			RV1A	T163A	28.4	✓	✓	
			RV2A	T11A	60	✓	✓	
			RV3A	T2A	120	✓	✓	
48	Ventable, Pilot-operated, Balanced Piston Relief Valve with Drain to Port 4		RV6A	T17A	240	✓	✓	
			RV8A	T19A	480	✓	✓	
			RV2D	T21A	60	✓	✓	
			RV3D	T22A	120	✓	✓	
48			RV6D	T23A	240	✓	✓	
			RV8D	T24A	480	✓	✓	

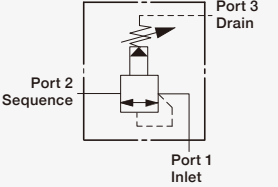
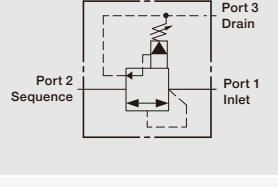
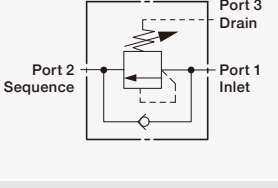
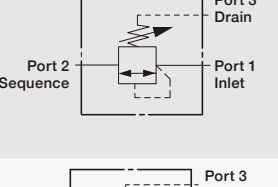
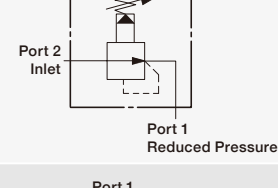
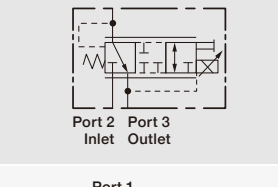
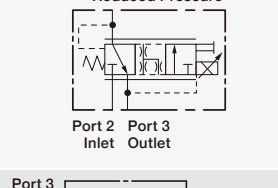
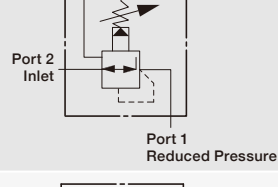
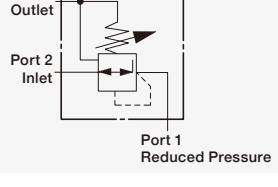
Page No.	Function	Symbols	Model No.	Cavity	Capacity (l/min)	Control Manner			
						L	K	X	M
50	Pilot Operated Sequence Valve		RS2C	T11A	60	✓	✓		
			RS3C	T2A	120	✓	✓		
			RS6C	T17A	240	✓	✓		
			RS8C	T19A	480	✓	✓		
52	Kick-down, Pilot-operated, Balanced Piston Sequence Valve		SQ2B	T11A	60	✓	✓		
			SQ3B	T2A	120	✓	✓		
			SQ6B	T17A	240	✓	✓		
			SQ8B	T19A	480	✓	✓		
54	Direct-acting Sequence Valve with Reverse Flow Check		SC2A	T11A	60	✓	✓		
			SC3A	T2A	120	✓	✓		
			SC6A	T17A	240	✓	✓		
			SC8A	T19A	480	✓	✓		
56	Direct-acting Sequence Valve without Reverse Flow Check		SX2A	T11A	60	✓	✓		
			SX3A	T2A	120	✓	✓		
58	Pilot Operated Reducing Valve		PB2B	T11A	40	✓	✓		
			PB3B	T2A	80	✓	✓		
			PB6B	T17A	160	✓	✓		
			PB8B	T19A	320	✓	✓		
60	Proportional, Direct Acting Pressure Reducing / Relieving, Low Leakage		PR2P	T11A	20				✓
62	Proportional, Direct Acting Pressure Reducing / Relieving, Better Dynamic Response		PR2L	T11A	20				✓
64	Pilot Operated Reducing / Relieving Valve		PP2B	T11A	40	✓	✓		
			PP3B	T2A	80	✓	✓		
			PP6B	T17A	160	✓	✓		
			PP8B	T19A	320	✓	✓		
66	Direct-acting Pressure Reducing / Relieving Valve		PR2B	T11A	40	✓	✓		
			PR3B	T2A	80	✓	✓		
			PR6B	T17A	160	✓	✓		
			PR8B	T19A	320	✓	✓		

Page No.	Function	Symbols	Model No.	Cavity	Capacity (l/min)	Control Manner			
						L	K	X	M
68	Proportional, Normally Closed, Flow Control Valve		FP2C	T13A	40				✓
70	Proportional, Normally Open, Flow Control Valve		FP2H	T13A	28				✓
72	Proportional, 3-way, Flow Control Valve		FM2A	T11A	34				✓
74	Fully Adjustable Needle Valve		NF1C	T162A	18.9	✓	✓		
			NF2C	T13A	25	✓	✓		
			NF3C	T5A	50	✓	✓		
			NF6C	T16A	100	✓	✓		
			NF8C	T18A	200	✓	✓		
76	Fully Adjustable and High Capacity Needle Valve		NF2D	T13A	80	✓	✓		
			NF3D	T5A	160	✓	✓		
			NF6D	T16A	320	✓	✓		
			NF8D	T18A	500	✓	✓		
78	Fully Adjustable Needle Valve (with Free Flow Check Valve)		NC2B	T13A	25	✓	✓		
			NC3B	T5A	50	✓	✓		
			NC6B	T16A	100	✓	✓		
			NC8B	T18A	200	✓	✓		
80	Pressure Compensated Fully Adjustable Flow Control Valve (with Free Flow Check Valve)		FD2A	T13A	23	✓	✓		
			FD3B	T5A	45	✓	✓		
			FD6A	T16A	95	✓	✓		
			FD8A	T18A	200	✓	✓		
82	Normally Closed, Modulating Element with Pilot Source from Port 1		LR2A	T11A	60	✓		✓	
			LR3A	T2A	120	✓		✓	
			LR6A	T17A	240	✓		✓	
			LR8A	T19A	480	✓		✓	
84	Normally Closed, Modulating Element		LR2C	T11A	60	✓		✓	
			LR3C	T2A	120	✓		✓	
			LR6C	T17A	240	✓		✓	
			LR8C	T19A	480	✓		✓	

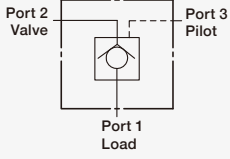
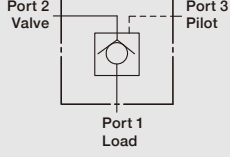
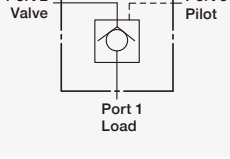
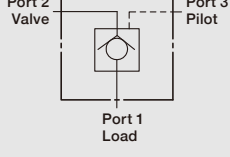
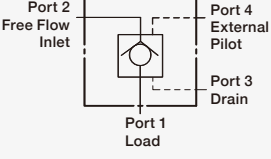
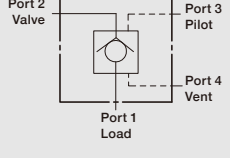
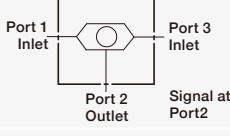
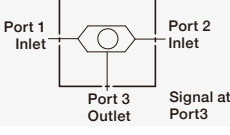
Page No.	Function	Symbols	Model No.	Cavity	Capacity (l/min)	Control Manner				
						L	K	X	V	E
86	Pilot-to-Open Check Valve with Standard Pilot & POM Seat		CK2A	T11A	60	✓		✓		
			CK3A	T2A	120	✓		✓		
			CK6A	T17A	240	✓		✓		
			CK8A	T19A	480	✓		✓		
88	Pilot-to-Open Check Valve with Standard Pilot		CK1B	T163A	28.4	✓		✓		
			CK2B	T11A	60	✓		✓		
			CK3B	T2A	120	✓		✓		
			CK6B	T17A	240	✓		✓		
90	Pilot-to-Open Check Valve with Sealed Pilot & POM Seat		CK2C	T11A	60	✓		✓		
			CK3C	T2A	120	✓		✓		
			CK6C	T17A	240	✓		✓		
			CK8C	T19A	480	✓		✓		
92	Pilot-to-Open Check Valve with Sealed Pilot		CK2D	T11A	60	✓		✓		
			CK3D	T2A	120	✓		✓		
			CK6D	T17A	240	✓		✓		
			CK8D	T19A	480	✓		✓		
94	Vented, Pilot-to-Open Check Valve with External Pilot Port		CK2F	T11A	60				✓	
			CK3F	T2A	120				✓	
			CK6F	T17A	240				✓	
			CK8F	T19A	480				✓	
96	Vented, Pilot-to-Open Check Valve		CV2V	T21A	60	✓		✓		
			CV3V	T22A	120	✓		✓		
			CV6V	T23A	240	✓		✓		
			CV8V	T24A	480	✓		✓		
98	Shuttle Valve		CS2D	T11A	10			✓		
			CS2B	T11A	10			✓		

Page No.	Function	Symbols	Model No.	Cavity	Capacity (l/min)	Control Manner				
						L	K	X	V	E
100	Shuttle Valve, with External Port		CS2A	T13A	10					✓
			CS2C	T13A	10					✓
102	Check Valve, Free Flow Port1 to Port2		CX2A	T13A	80			✓		
			CX3A	T5A	160			✓		
			CX7A	T16A	320			✓		
			CX8A	T18A	640			✓		
104	Check Valve, Free Flow Port2 to Port1 with POM Seat		CX2B	T13A	60			✓		
			CX3B	T5A	120			✓		
			CX6B	T16A	240			✓		
			CX8B	T18A	480			✓		
106	Check Valve, Free Flow Port2 to Port1		CX2D	T13A	60			✓		
			CX3D	T5A	120			✓		
			CX7D	T16A	240			✓		
			CX8D	T18A	480			✓		

Load Holding

Page No.	Function	Symbols	Model No.	Cavity	Capacity (l/min)	Control Manner		
						L	K	X
108	3:1 Pilot Ratio, Vented Counterbalance Valve - Atmospherically Referenced		CA2A	T11A	60	✓		
			CA3A	T2A	120	✓		
			CA6A	T17A	240	✓		
			CA8A	T19A	480	✓		
110	5:1 Pilot Ratio, Vented Counterbalance Valve - Atmospherically Referenced		CA2G	T11A	60	✓		
			CA3G	T2A	120	✓		
			CA6G	T17A	240	✓		
			CA8G	T19A	480	✓		
112	Counterbalance 3:1 Pilot Ratio External Pilot Non-Vented Valve		CB2A	T11A	60	✓		
			CB3A	T2A	120	✓		
			CB6A	T17A	240	✓		
			CB8A	T19A	480	✓		

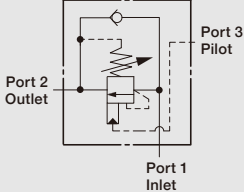
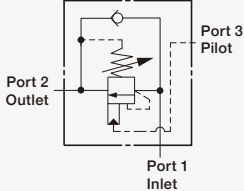
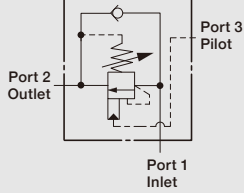
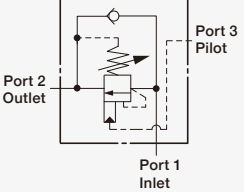
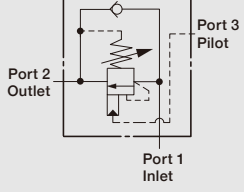
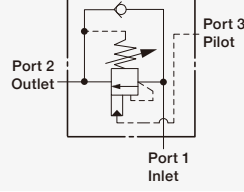
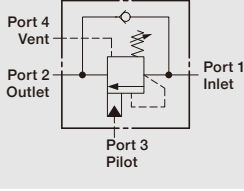
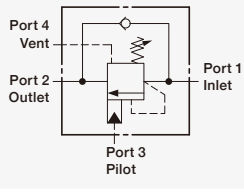
Page No.	Function	Symbols	Model No.	Cavity	Capacity (l/min)	Control Manner		
						L	K	X
114	Counterbalance 4.5:1 Pilot Ratio External Pilot Non-Vented Valve		CB2G	T11A	60	✓		
			CB3G	T2A	120	✓		
			CB6G	T17A	240	✓		
			CB8G	T19A	480	✓		
116	Counterbalance 10:1 Pilot Ratio External Pilot Non-Vented Valve		CB2H	T11A	60	✓		
			CB3H	T2A	120	✓		
			CB6H	T17A	240	✓		
			CB8H	T19A	480	✓		
118	3:1 Pilot Ratio, Semi-restrictive Counterbalance Valve		CB2C	T11A	40	✓		
			CB3C	T2A	80	✓		
			CB6C	T17A	160	✓		
120	4.5:1 Pilot Ratio, Semi-restrictive Counterbalance Valve		CB2D	T11A	40	✓		
			CB3D	T2A	80	✓		
			CB6D	T17A	160	✓		
122	3:1 Pilot Ratio, Restrictive Counterbalance Valve		CB2E	T11A	15	✓		
			CB3E	T2A	30	✓		
			CB6E	T17A	60	✓		
			CB8E	T19A	80	✓		
124	4.5:1 Pilot Ratio, Restrictive Counterbalance Valve		CB2F	T11A	15	✓		
			CB3F	T2A	30	✓		
			CB6F	T17A	60	✓		
			CB8F	T19A	80	✓		
126	3:1 Pilot Ratio, Vented, Counterbalance Valve		CW2A	T21A	60	✓		
			CW3A	T22A	120	✓		
			CW6A	T23A	240	✓		
			CW8A	T24A	480	✓		
128	5:1 Pilot Ratio, Vented, Counterbalance Valve		CW2G	T21A	60	✓		
			CW3G	T22A	120	✓		
			CW6G	T23A	240	✓		
			CW8G	T24A	480	✓		

Page No.	Function	Symbols	Model No.	Cavity	Capacity (l/min)	Control Manner		
						L	K	X
130	Logic Elements (Spring biased closed, pilot source from port 1)		LO2A	T11A	80	✓		✓
			LO3A	T2A	160	✓		✓
			LO6A	T17A	320	✓		✓
			LO8A	T19A	640	✓		✓
130	Logic Elements (Spring biased closed, pilot source from port 2)		LO2B	T11A	80	✓		✓
			LO3B	T2A	160	✓		✓
			LO6B	T17A	320	✓		✓
			LO8B	T19A	640	✓		✓
130	Logic Elements (Spring biased closed, pilot source from port 3)		LO2C	T11A	80	✓		✓
			LO3C	T2A	160	✓		✓
			LO6C	T17A	320	✓		✓
			LO8C	T19A	640	✓		✓
130	Logic Elements (Spring biased closed, higher of port 1 or 2 pilot source)		LO2D	T11A	80	✓		✓
			LO3D	T2A	160	✓		✓
			LO6D	T17A	320	✓		✓
			LO8D	T19A	640	✓		✓
130	Logic Elements (Spring biased open, pilot source from port 3)		LO2O	T11A	80	✓		✓
			LO3O	T2A	160	✓		✓
			LO6O	T17A	320	✓		✓
			LO8O	T19A	640	✓		✓
132	Normally Open, Logic Modulating, Internal Pilot		LP2A	T11A	60	✓		✓
			LP3A	T2A	120	✓		✓
			LP6A	T17A	240	✓		✓
			LP8A	T19A	480	✓		✓
132	Normally Open, Logic Modulating, External Pilot		LP2C	T11A	60	✓		✓
			LP3C	T2A	120	✓		✓
			LP6C	T17A	240	✓		✓
			LP8C	T19A	480	✓		✓

Page No.	Function	Symbols	Model No.	Cavity	Capacity (l/min)	Control Manner		
						L	K	X
134	Fixed Orifice, Flow Fuse Valve		FQ2A	T13A	23			✓
			FQ3A	T5A	60			✓
			FQ6A	T16A	95			✓
			FQ8A	T18A	200			✓
136	1.8:1 Pilot Ratio, Pilot to Close Check Valve		CO1A	T163A	40			✓
			CO2A	T11A	80			✓
			CO3A	T2A	160			✓
			CO6A	T17A	320			✓
			CO8A	T19A	640			✓
138	120:1 Pilot Ratio, Pilot to Close Check Valve		CO3O	T2A	4			✓
140	30%, Accumulator Sense, Pump Unload Valve with Check - Pilot Capacity		QC2A	T21A	60	✓	✓	
			QC2B	T21A	60	✓	✓	
			QC2C	T21A	60	✓	✓	

Page No.	Function	Symbols	Model No.	Cavity	Thread
142	2 Holes External Port Blocked Cavity Plug		X10A2	T162A	M16 P15
			X20A2	T10A	M20 P1.5
			X20A2	T13A	M20 P1.5
			X30A2	T3A	1"-14UNS-2B
			X30A2	T5A	1"-14UNS-2B
			X60A2	T16A	M36 P2
			X80A2	T18A	M48 P2
143	2 Holes All Ports Blocked Cavity Plug		X1CA2	T162A	M16 P15
			X2CA2	T10A	M20 P1.5
			X2CA2	T13A	M20 P1.5
			X3CA2	T3A	1"-14UNS-2B
			X3CA2	T5A	1"-14UNS-2B
			X6CA2	T16A	M36 P2
			X8CA2	T18A	M48 P2
144	Port 1 to 2 Open, Port 3 Blocked Cavity Plug		X10A3	T163A	M16 P1.5
			X20A3	T11A	M20 P1.5
			X30A3	T2A	1"-14UNS-2B
			X60A3	T17A	M36 P2
			X80A3	T19A	M48 P2
145	3 Holes All Ports Blocked Cavity Plug		X1CA3	T163A	M16 P1.5
			X2CA3	T13A	M20 P1.5
			X3CA3	T2A	1"-14UNS-2B
			X6CA3	T17A	M36 P2
			X8CA3	T19A	M48 P2

Electronic Amplifier P-C Board

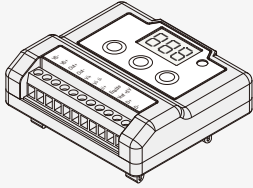
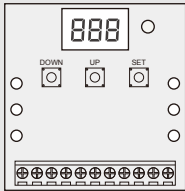
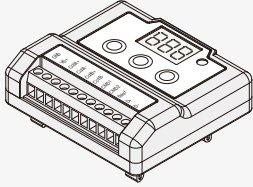
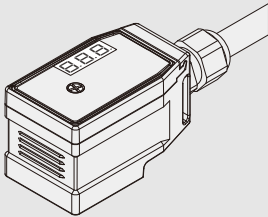
Page No.	Function	Appearance	Model No.	Type
146	Digital Proportional Controller - Case		SY-DPCA-C-1	Case with DIN-35 rail clamps
148	Digital Proportional Controller - PCB Only		SY-DPCA-P-1	PCB only
150	Dual Output Proportional Controller		SY-DPCA-C-2	Case with DIN-35 rail clamps
152	Digital Proportional Controller - DIN Plug		SY-DPCA-D-P9-1	DIN43650A plug

Filter

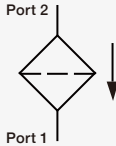
Page No.	Function	Symbols	Model No.	Cavity	Capacity (l/min)	Control Manner		
						L	K	X
154	Filter		FL2A	T13A	37.9			✓
			FL3A	T5A	75.7			✓
			FL6A	T16A	151.4			✓
			FL8A	T18A	302.8			✓

SAE Cavity Cartridge Valve > Flow Control

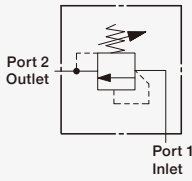
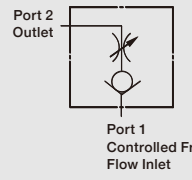
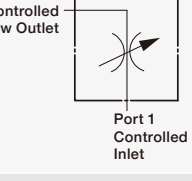
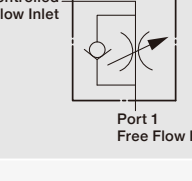
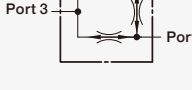
Page No.	Function	Symbols	Model No.	Cavity	Capacity (l/min)	Control Manner			
						L	K	X	C
158	Noiseless Direct Acting Diagonal Area Relief Valve		MH-082	T082	25	✓	✓		✓
			MH-092	T092	45	✓	✓		✓
			MH-102	T102	45	✓	✓		✓
			MH-122	T122	85	✓	✓		✓
160	Check with Manual Flow Adjustment		CN-082	T082	30	✓	✓		
			CN-102	T102	50	✓	✓		
			CN-122	T122	80	✓	✓		
			CN-162	T162	150	✓	✓		
162	Fully Adjustable Needle		NV-082	T082	30	✓	✓		
			NV-102	T102	50	✓	✓		
			NV-122	T122	80	✓	✓		
			NV-162	T162	150	✓	✓		
164	Fully Adjustable Needle with Free Flow Check		NC-082	T082	30	✓	✓		
			NC-102	T102	50	✓	✓		
			NC-122	T122	80	✓	✓		
			NC-162	T162	150	✓	✓		
166	Flow Divider (Flow Ratio: 1:1)		CP-104	T104	45			✓	
			CP-124	T124	75			✓	
			CP-164	T164	150			✓	

SAE Cavity Cartridge Valve > Directional

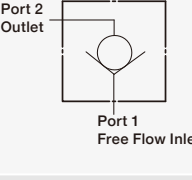
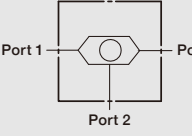
Page No.	Function	Symbols	Model No.	Cavity	Capacity (l/min)	Control Manner		
						L	K	X
168	Check Free Flow 1-2, , Poppet Type		CV-082	T082	30			✓
			CV-102	T102	50			✓
			CV-122	T122	80			✓
			CV-162	T162	150			✓
170	Shuttle Valve		LS-083	T083	15			✓
			LS-103	T103	30			✓

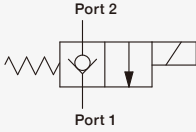
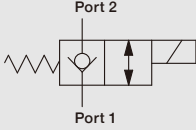
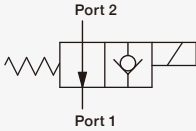
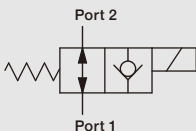
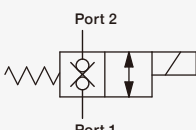
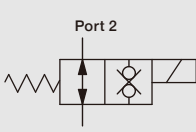
Page No.	Function	Symbols	Model No.	Cavity	Capacity (l/min)	Control Manner		
						L	K	X
172	Normally Closed Single Check		HS-2A	T082	28			✓
			JS-2A	T102	50			✓
			LS-2A	T122	100			✓
			PS-2A	T162	150			✓
174	Normally Closed Single Check Reverse Flow		HS-2B	T082	28			✓
			JS-2B	T102	50			✓
			LS-2B	T122	100			✓
			PS-2B	T162	150			✓
176	Normally Open Single Check		HS-2C	T082	28			✓
			JS-2C	T102	50			✓
			LS-2C	T122	100			✓
			PS-2C	T162	150			✓
178	Normally Open Single Check Reverse Flow		HS-2D	T082	28			✓
			JS-2D	T102	50			✓
			LS-2D	T122	100			✓
			PS-2D	T162	150			✓
180	Normally Closed Double Check		HS-2I	T082	28			✓
			JS-2I	T102	50			✓
			LS-2I	T122	100			✓
			PS-2I	T162	150			✓
182	Normally Open Double Check		HS-2J	T082	28			✓
			JS-2J	T102	50			✓
			LS-2J	T122	100			✓
			PS-2J	T162	150			✓

Page No.	Function	Symbols	Model No.	Cavity	Capacity (l/min)	Control Manner		
						L	K	X
184	3 Way, 2 Position		HS-3A	T082	15			✓
			JS-3A	T102				✓
186	3 Way, 2 Position		HS-3X	T082	13			✓
			JS-3X	T102	38			✓

DTA



SYMBOLS

normally closed

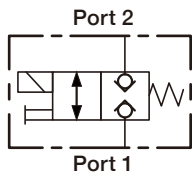

normally open

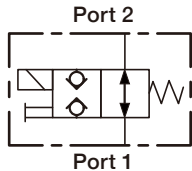

ORDER CODES

DT **2** **A** - **T13A** - **M** **C** **N** - **DG** **24**

1 2 3 4 5 6 7 8

1	Model Name	DT	
2	Capacity (l/min)	2	40
3	Cavity	T13A	
4	Control Manner	M	manual override
5	Type	C	normally closed
		H	normally open
6	Material of Seal	N	buna-N
		V	viton
		E	EPDM
		H	HNBR
		U	polyurethane
7	Connector (coil)	DG	ISO/DIN43650
		DR	Deutsch DT04-2P
8	Voltage (coil)	12	12 VDC
		24	24 VDC

MODEL SPEC.

Model	Cavity	Capacity (l/min)	Max. Pressure (bar)	Leakage	Installation Torque (Nm)
DT2A	T13A	40	350	less than 0.7 cc/min	45/50
Model	Max. Current	Power Consumption (watts)	Body's Weight (kg)	Coil's Weight (kg)	
DT2A	1820mA@12VDC 910mA@24VDC	22	0.24	0.23	

PERFORMANCE CURVES

► Pressure Differential vs. Flow

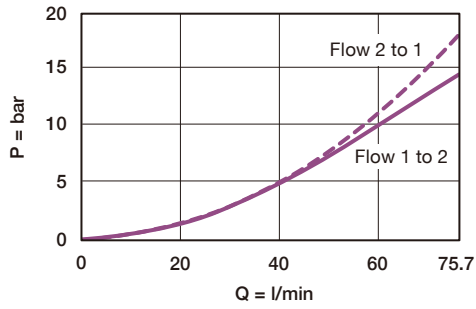

► Valve Performance Limits @ 10% Undervoltage & Stabilized Coil Temperature

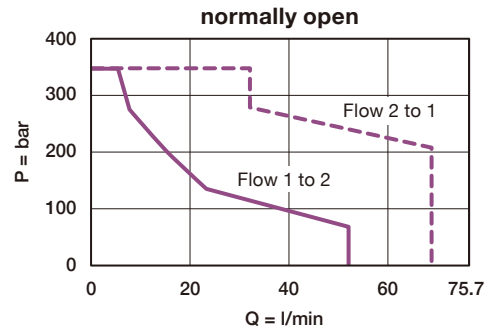
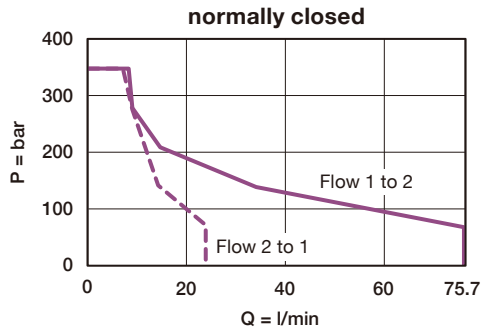

DIMENSION

(UNIT : mm)

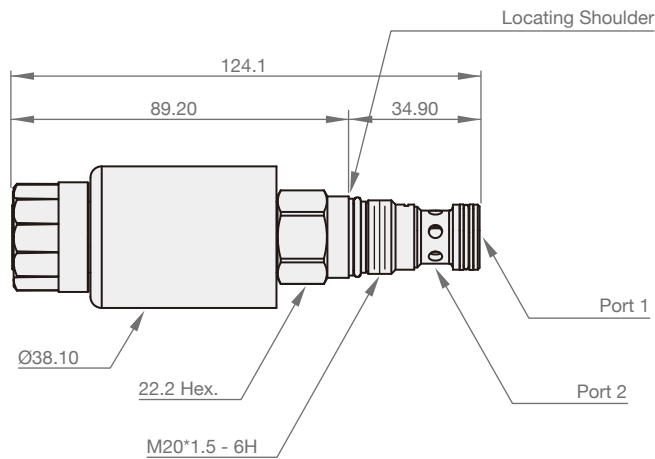

DWA



SYMBOLS

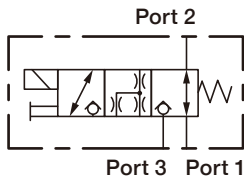

ORDER CODES

DW **2** **A** - **T11A** - **M** **A** **N** - **DR** **24**

1 2 3 4 5 6 7 8

1	▶ Model Name	DW	
2	▶ Capacity (l/min)	2	30
3	▶ Cavity	T11A	
4	▶ Control Manner	M	manual override
5	▶ Type	A	1-2 normally open, 2-3 closed
6	▶ Material of Seal	N	buna-N
		V	viton
		E	EPDM
		H	HNBR
		U	polyurethane
7	▶ Connector (coil)	DG	ISO/DIN43650
		DR	Deutsch DT04-2P
8	▶ Voltage (coil)	12	12 VDC
		24	24 VDC

MODEL SPEC.

Model	Cavity	Capacity (l/min)	Max. Pressure (bar)	Leakage	Installation Torque (Nm)
DW2A	T11A	30	350	less than 0.7 cc/min	45/50
Model	Max. Current	Power Consumption (watts)	Body's Weight (kg)	Coil's Weight (kg)	
DW2A	1820mA@12VDC 910mA@24VDC	22	0.28	0.23	

PERFORMANCE CURVES

► Pressure Differential vs. Flow

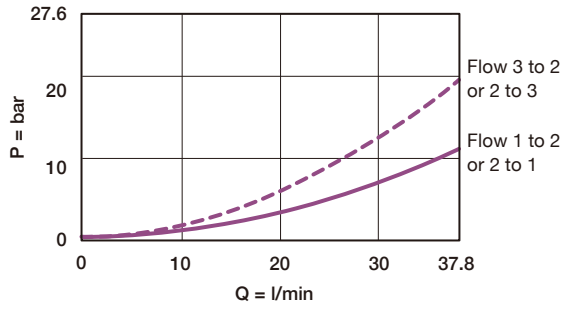

► Valve Performance Limits @ 10% Undervoltage & Stabilized Coil Temperature

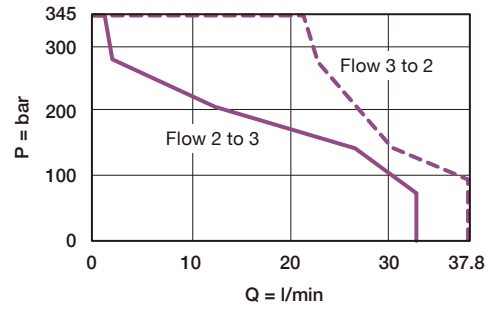
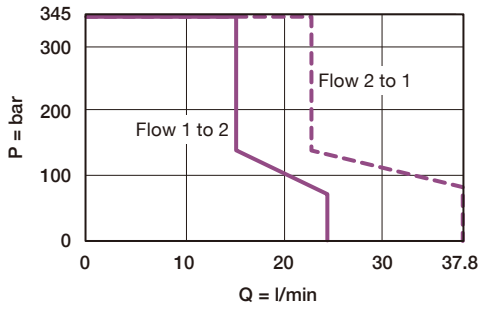

DIMENSION

(UNIT : mm)

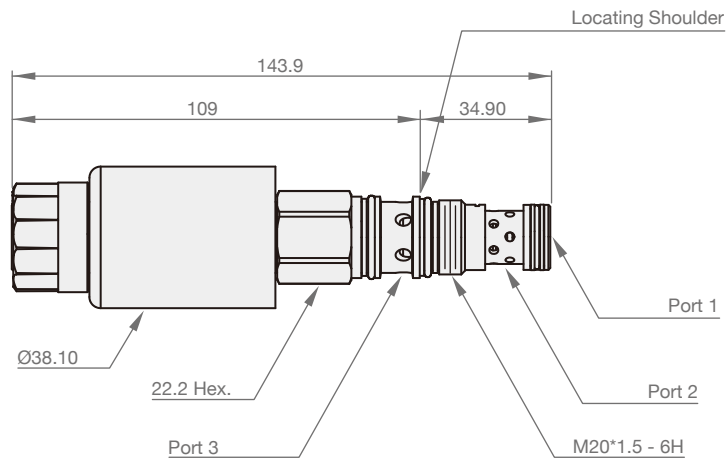

DLA



SYMBOLS

normally closed

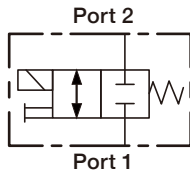

normally open

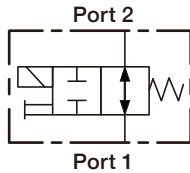

ORDER CODES

DL 2 A - T13A - M C N - DG 24

1 2 3 4 5 6 7 8

1	Model Name	DL	
2	Capacity (l/min)	2	45
3	Cavity	T13A	
4	Control Manner	M	manual override
5	Type	C	normally closed
		H	normally open
6	Material of Seal	N	buna-N
		V	viton
		E	EPDM
		H	HNBR
		U	polyurethane
7	Connector (coil)	DG	ISO/DIN43650
		DR	Deutsch DT04-2P
8	Voltage (coil)	12	12 VDC
		24	24 VDC

MODEL SPEC.

Model	Cavity	Capacity (l/min)	Max. Pressure (bar)	Leakage	Installation Torque (Nm)
DL2A	T13A	45	350	less than 100 cc/min	40/50
Model	Max. Current	Power Consumption (watts)	Body's Weight (kg)	Coil's Weight (kg)	
DL2A	1820mA@12VDC 910mA@24VDC	22	0.24	0.23	

PERFORMANCE CURVES

► Typical Pressure Differential vs. Flow

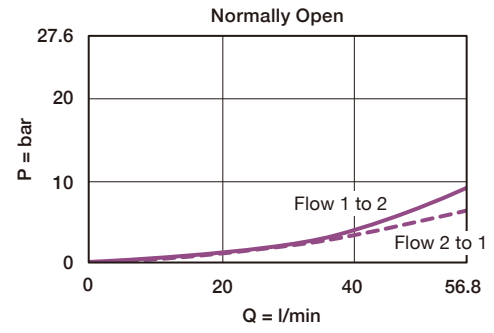
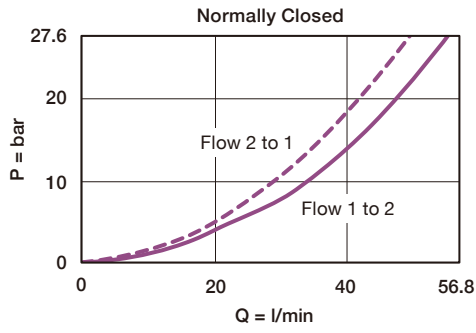

► Valve Performance Limits @ 10% Undervoltage & Stabilized Coil Temperature

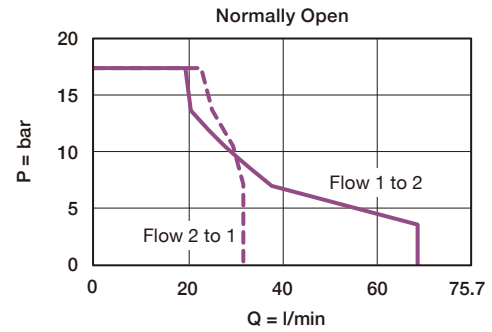
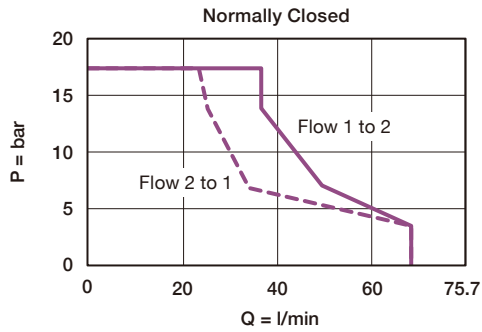

DIMENSION

(UNIT : mm)

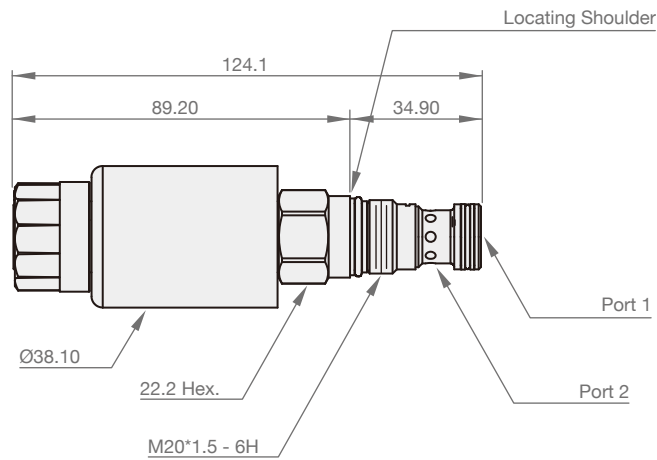

DMA



SYMBOLS

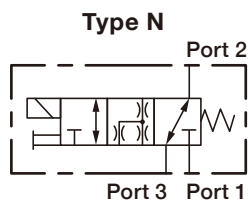
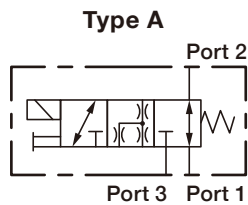

ORDER CODES

DM 2 A - T11A - M A N - DR 24

1 2 3 4 5 6 7 8

1	▶ Model Name	DM
2	▶ Capacity (l/min)	2 45
3	▶ Cavity	T11A
4	▶ Control Manner	M manual override
5	▶ Type	A 1-2 normally open, 2-3 closed N 2-3 normally open, 1-2 closed
6	▶ Material of Seal	N buna-N V viton E EPDM H HNBR U polyurethane
7	▶ Connector (coil)	DG ISO/DIN43650 DR Deutsch DT04-2P
8	▶ Voltage (coil)	12 12 VDC 24 24 VDC

MODEL SPEC.

Model	Cavity	Capacity (l/min)	Max. Pressure (bar)	Leakage	Installation Torque (Nm)
DM2A	T11A	45	350	less than 100 cc/min	40/50
Model	Max. Current	Power Consumption (watts)	Body's Weight (kg)	Coil's Weight (kg)	
DM2A	1820mA@12VDC 910mA@24VDC	22	0.28	0.23	

PERFORMANCE CURVES

► Typical Pressure Differential vs. Flow

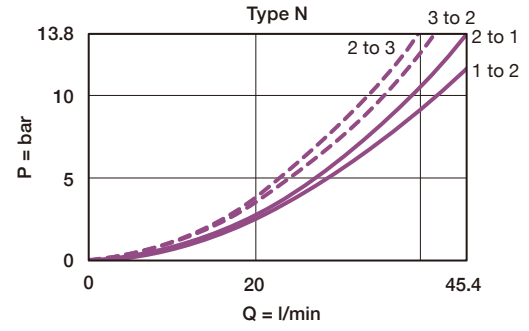
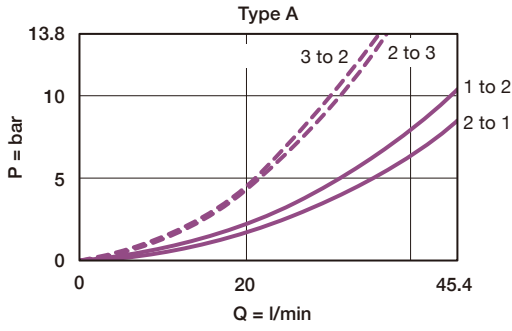

► Valve Performance Limits @ 10% Undervoltage & Stabilized Coil Temperature

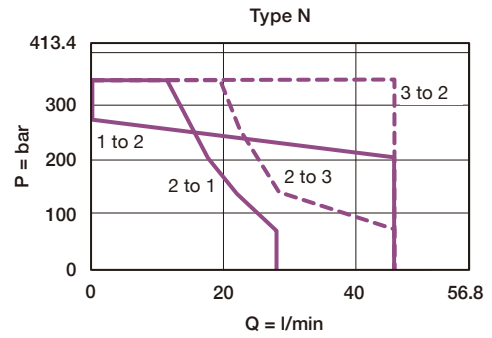
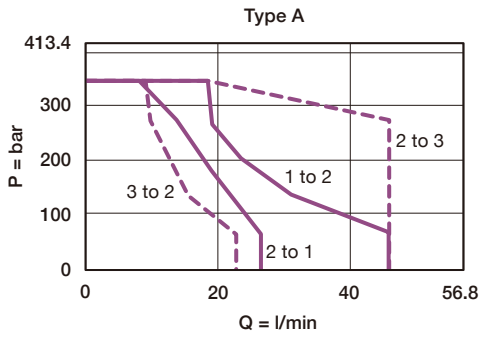

DIMENSION

(UNIT : mm)

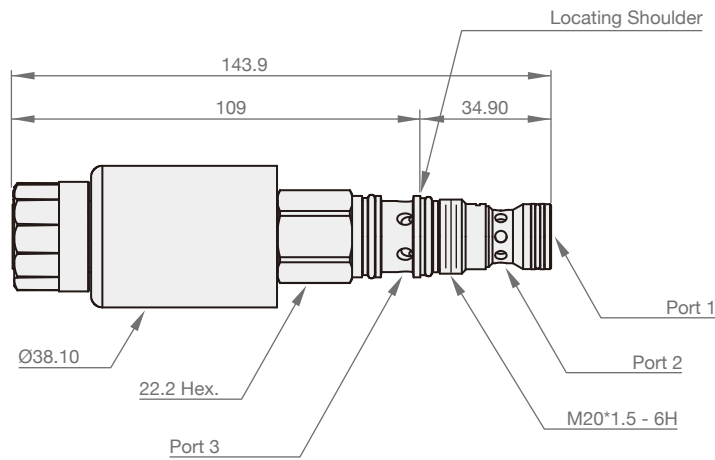

RBP



SYMBOLS

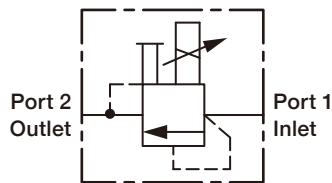

ORDER CODES

RB 1 P - T8A - M A N - DG 24

1 2 1 3 4 5 6 7 8

1	▶ Model Name	RBP	
2	▶ Capacity (l/min)	1	1
3	▶ Cavity	T8A	
4	▶ Control Manner	M	manual override
5	▶ Adjustment Range (bar)	A	20 ~ 210
		B	10.5 ~ 105
		D	3.5 ~ 50
		W	35 ~ 350
6	▶ Material of Seal	N	buna-N
		V	viton
		E	EPDM
		H	HNBR
		U	polyurethane
7	▶ Connector (coil)	DG	ISO/DIN43650
		DR	Deutsch DT04-2P
8	▶ Voltage (coil)	12	12 VDC
		24	24 VDC

MODEL SPEC.

Model	Cavity	Capacity (l/min)	Max. Pressure (bar)	Leakage	Installation Torque (Nm)
RB1P	T8A	1	350	less than 25 cc/min	9/10
Model	Hysteresis	Max. Current	Power Consumption (watts)	Body's Weight (kg)	Coil's Weight (kg)
RB1P	5%	1820mA@12VDC 910mA@24VDC	22	0.26	0.23

PERFORMANCE CURVES

► Pressure vs. Command (Range A)

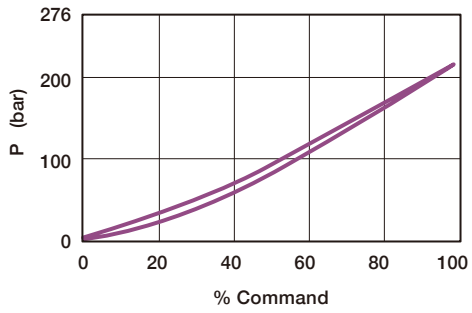

► Typical Pressure Rise

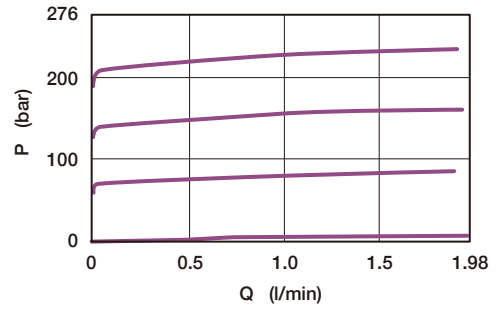

DIMENSION

(UNIT : mm)

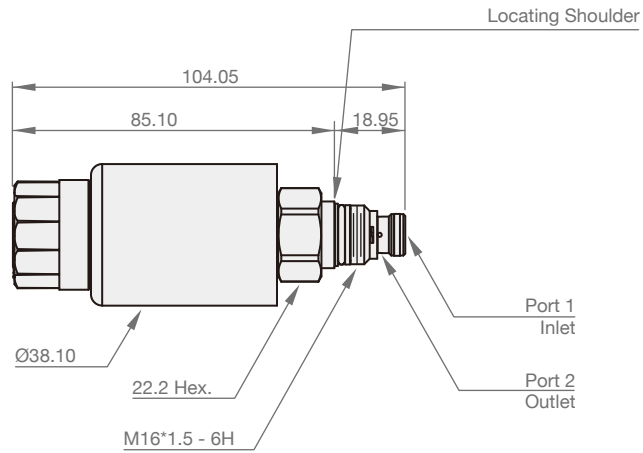

RBN



SYMBOLS

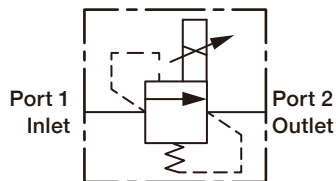

ORDER CODES

RB 1 N - T8A - M A N - DR 24

1 2 1 3 4 5 6 7 8

1	▶ Model Name	RBN	
2	▶ Capacity (l/min)	1	1
3	▶ Cavity	T8A	
4	▶ Control Manner	M	manual override
5	▶ Adjustment Range (bar)	A	105 ~ 210
		B	55 ~ 105
		D	20 ~ 55
		W	210 ~ 350
6	▶ Material of Seal	N	buna-N
		V	viton
		E	EPDM
		H	HNBR
		U	polyurethane
7	▶ Connector (coil)	DG	ISO/DIN43650
		DR	Deutsch DT04-2P
8	▶ Voltage (coil)	12	12 VDC
		24	24 VDC

MODEL SPEC.

Model	Cavity	Capacity (l/min)	Max. Pressure (bar)	Leakage	Installation Torque (Nm)
RB1N	T8A	1	350	less than 25 cc/min	9/10
Model	Hysteresis	Max. Current	Power Consumption (watts)	Body's Weight (kg)	Coil's Weight (kg)
RB1N	5%	1820mA@12VDC 910mA@24VDC	22	0.45	0.23

PERFORMANCE CURVES

► Pressure vs. Command (Range A)

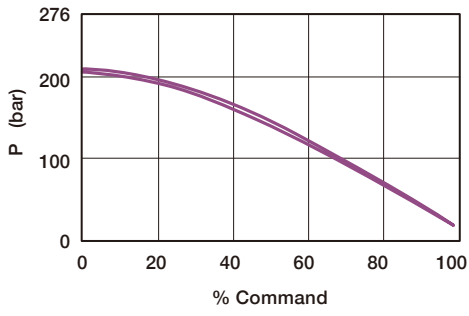

► Pressure Differential vs. Flow (Range A)

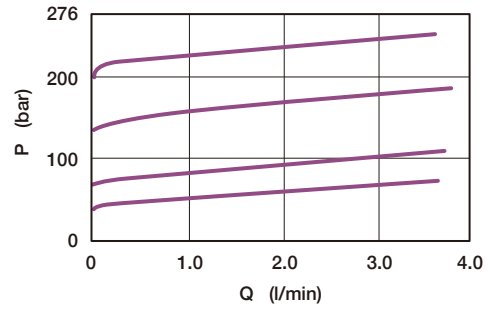

DIMENSION

(UNIT : mm)

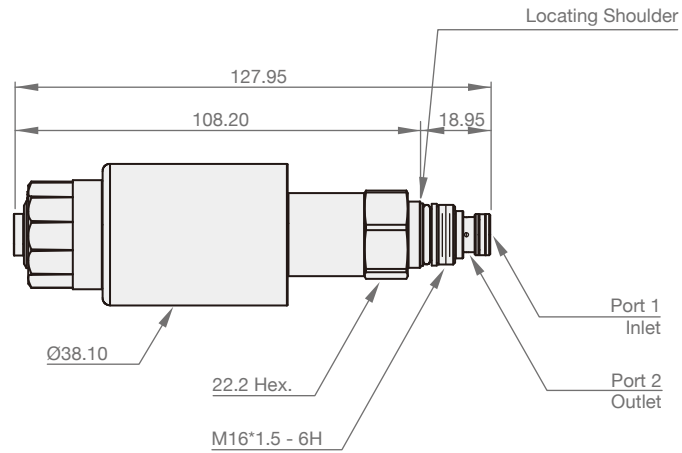

RBC, RBA



SYMBOLS

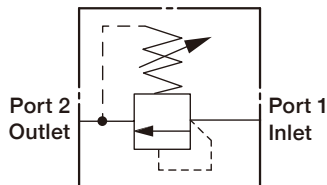

ORDER CODES

RB **2C** - **T10A** - **L** **A** **N**

① ② ③ ④ ⑤ ⑥

①	Model Name	RB	
②	Capacity	2C	1 l/min
		3A	2 l/min
③	Cavity	T10A, T3A	
④	Control Manner	L	standard screw adjustment
		K	hand knob with lock knob
⑤	Adjustable Range	A	7 ~ 210 bar
		B	3.5 ~ 105 bar
		C	10.5 ~ 400 bar
		N	5 ~ 55 bar
		⑥	Material of Seal
		V	viton
		E	EPDM
		H	HNBR
		U	polyurethane

MODEL SPEC.

Model	Cavity	Capacity (l/min)	Max. Pressure (bar)	Installation Torque (Nm)	Operating Temperature	Weight (kg)
RB2C	T10A	1	350	45/50	-35 ~ 100°C (-31 ~ 212°F)	0.15
RB3A	T3A	2	350	60/70		0.25

PERFORMANCE CURVES

► Typical Pressure Rise

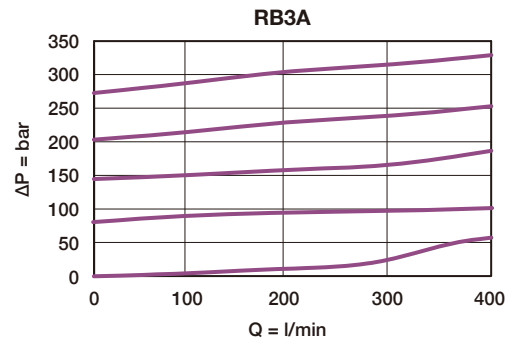
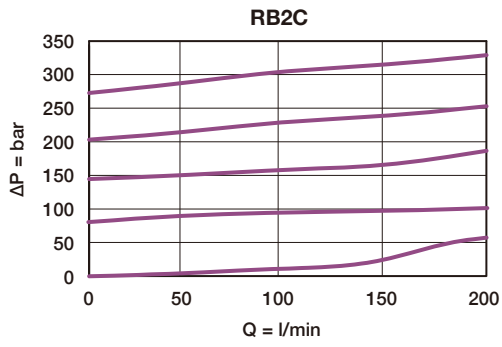

DIMENSION

(UNIT : mm)

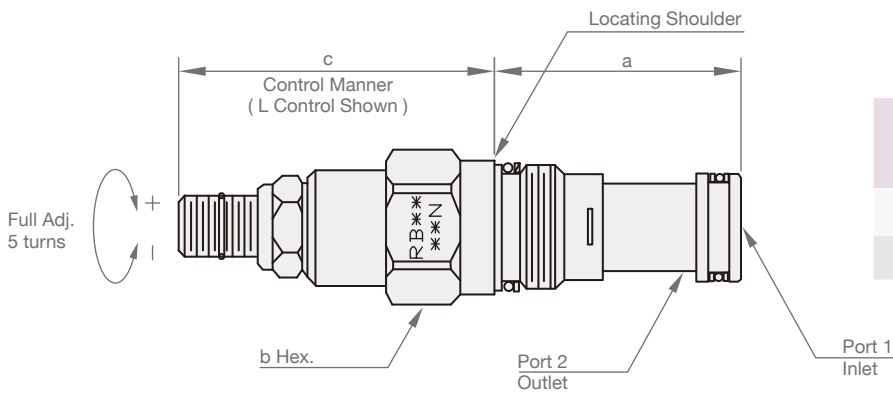

Model	a	b	c	
			L	K
RB2C	39.7	22.2	51	58
RB3A	47.8	28.6	54	61

RPC8



SYMBOLS

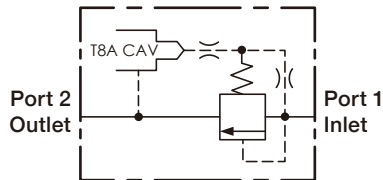

ORDER CODES

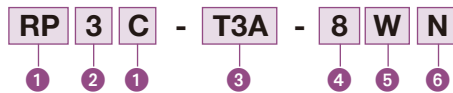

1	▶ Model Name	RPC	
2	▶ Valve Size	2, 3, 6, 8	
3	▶ Cavity	T10A, T3A, T16A, T18A	
4	▶ Control Manner	8	integral cavity T8A
5	▶ Cracking Pressure (bar)	W	7
		D	1.7
6	▶ Material of Seal	N	buna-N
		V	viton
		E	EPDM
		H	HNBR
		U	polyurethane

MODEL SPEC.

Model	Cavity	Capacity (l/min)	Max. Pressure (bar)	Installation Torque (Nm)	Operating Temperature	Weight (kg)
RP2C8	T10A	95	350	40/50	-35 ~ 100°C (-31 ~ 212°F)	0.09
RP3C8	T3A	200	350	60/70		0.17
RP6C8	T16A	380	350	200/215		0.43
RP8C8	T18A	760	350	465/500		0.59

PERFORMANCE CURVES

► Typical Pressure Rise

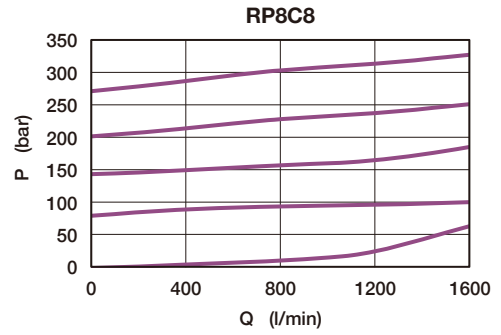
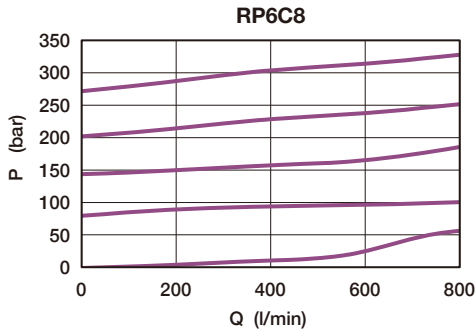
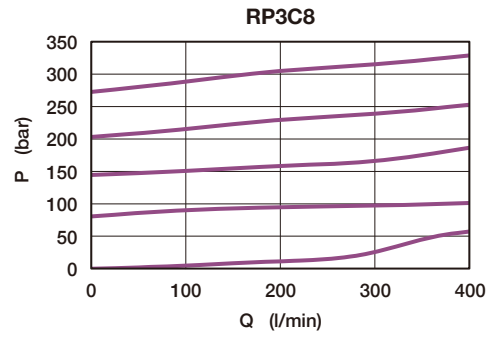
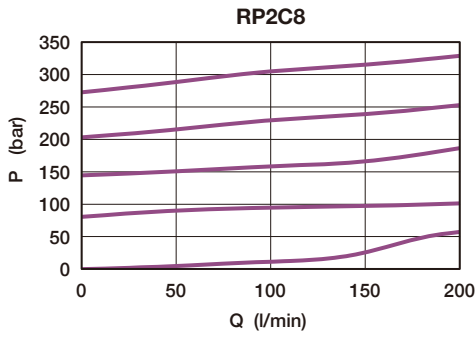

DIMENSION

(UNIT : mm)

T8A pilot capacity relief is not included and has to be ordered separately. Refer to RB1P

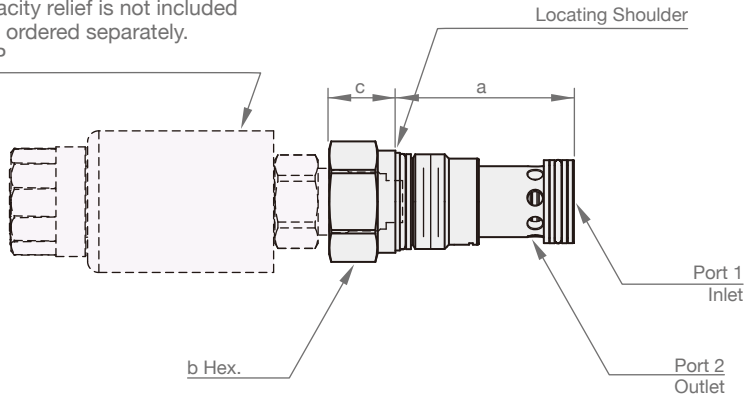

Model	a	b	c
RP2C8	39.7	22.2	19
RP3C8	47.8	28.6	17.5
RP6C8	61.9	31.8	24.6
RP8C8	79.4	41.3	30.2

RPC



SYMBOLS

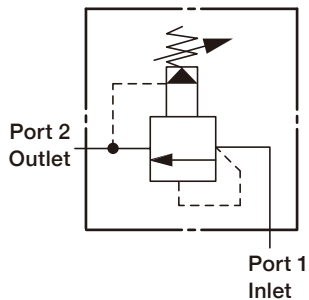

ORDER CODES

RP 2 C - T10A - L A N

1 2 1 3 4 5 6

1	▶ Model Name	RPC	
2	▶ Valve Size	2, 3, 6, 8	
3	▶ Cavity	T10A, T3A, T16A, T18A	
4	▶ Control Manner	L	standard screw adjustment
		K	hand knob with lock knob
		▶ Adjustable Range	
		A	7 ~ 210 bar
5	▶ Adjustable Range	B	3.5 ~ 105 bar
		C	10.5 ~ 400 bar
		N	5 ~ 55 bar
		W	10.5~315 bar
6	▶ Material of Seal	N	buna-N
		V	viton
		E	EPDM
		H	HNBR
		U	polyurethane

MODEL SPEC.

Model	Cavity	Capacity (l/min)	Max. Pressure (bar)	Installation Torque (Nm)	Operating Temperature	Weight (kg)
RP2C	T10A	95	350	40/50	-35 ~ 100°C (-31 ~ 212°F)	0.15
RP3C	T3A	200	350	60/70		0.25
RP6C	T16A	380	350	200/215		0.55
RP8C	T18A	760	350	465/500		1.17

PERFORMANCE CURVES

► Typical Pressure Rise

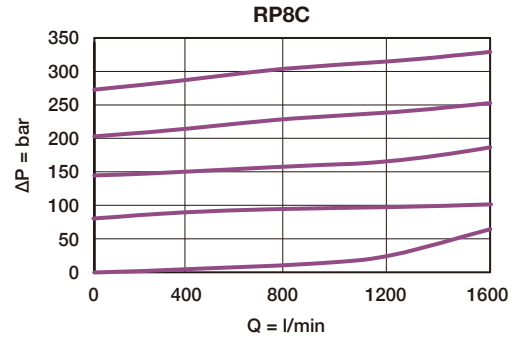
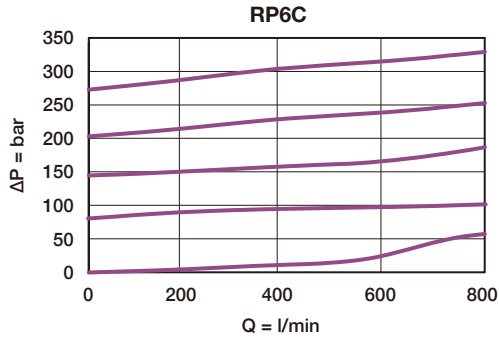
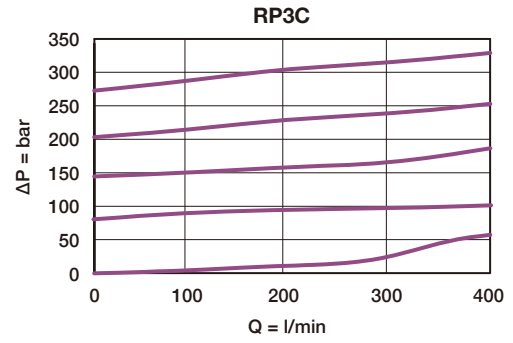
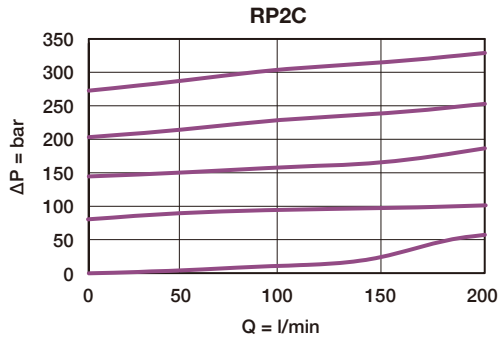

DIMENSION

(UNIT : mm)

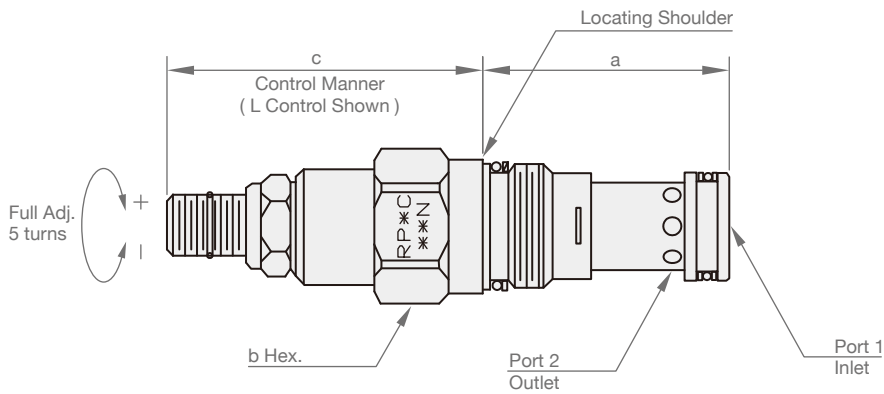

Model	a	b	c	
			L	K
RP2C	39.7	22.2	51	58
RP3C	47.8	28.6	54	61
RP6C	61.9	31.8	62	69
RP8C	79.4	41.3	71	78

RPE



SYMBOLS

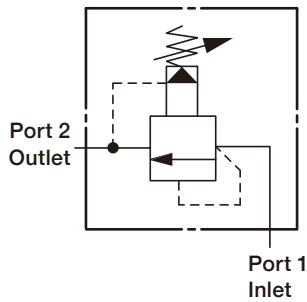

ORDER CODES

RP 2 E - T10A - L A N

1 2 1 3 4 5 6

1	Model Name	RPE	
2	Valve Size	2, 3, 6, 8	
3	Cavity	T10A, T3A, T16A, T18A	
4	Control Manner	L	standard screw adjustment
		K	hand knob with lock knob
5	Adjustable Range	A	7 ~ 210 bar
		B	3.5 ~ 105 bar
		C	10.5 ~ 400 bar
		N	5 ~ 55 bar
6	Material of Seal	N	buna-N
		V	viton
		E	EPDM
		H	HNBR
		U	polyurethane

MODEL SPEC.

Model	Cavity	Capacity (l/min)	Max. Pressure (bar)	Installation Torque (Nm)	Operating Temperature	Weight (kg)
RP2E	T10A	95	350	40/50	-35 ~ 100°C (-31 ~ 212°F)	0.15
RP3E	T3A	200	350	60/70		0.25
RP6E	T16A	380	350	200/215		0.55
RP8E	T18A	760	350	465/500		1.17

PERFORMANCE CURVES

► Typical Pressure Rise

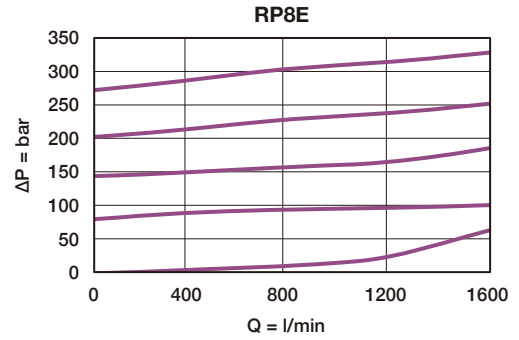
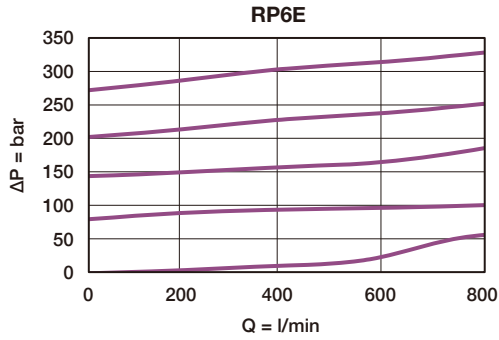
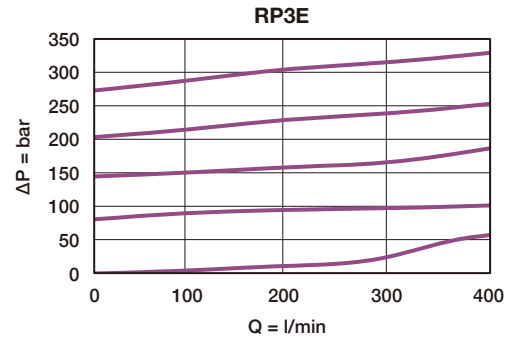
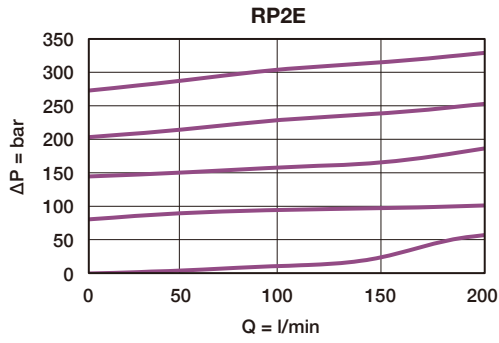

DIMENSION

(UNIT : mm)

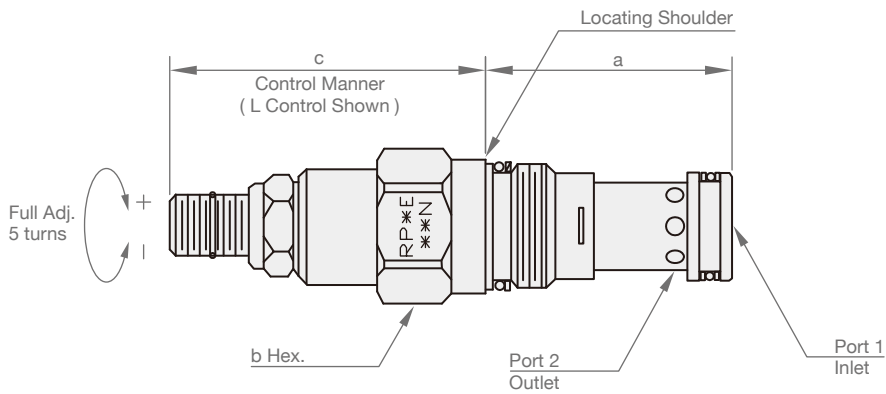

Model	a	b	c	
			L	K
RP2E	39.7	22.2	51	58
RP3E	47.8	28.6	54	61
RP6E	61.9	31.8	62	69
RP8E	79.4	41.3	71	78

RD



SYMBOLS

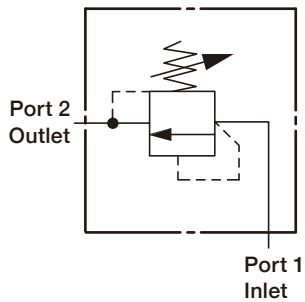

ORDER CODES

RD 2A - T10A - L A N

1 2 3 4 5 6

1	Model Name	RD	
2	Valve Size	1A, 2A, 3A, 6A, 8A	
3	Cavity	T162A, T10A, T3A, T16A, T18A	
4	Control Manner	L	standard screw adjustment
5	Adjustable Range	A	35 ~ 210 bar
		B	20 ~ 105 bar
		C	70 ~ 420 bar
		D	14 ~ 55 bar
6	Material of Seal	N	buna-N
		V	viton
		E	EPDM
		H	HNBR
		U	polyurethane

MODEL SPEC.

Model	Cavity	Capacity (l/min)	Max. Pressure (bar)	Installation Torque (Nm)	Operating Temperature	Weight (kg)
RD1A	T162A	28.4	350	27/33	-35 ~ 100°C (-31 ~ 212°F)	0.1
RD2A	T10A	95	350	40/50		0.155
RD3A	T3A	200	350	60/70		0.295
RD6A	T16A	380	350	200/215		0.670
RD8A	T18A	760	350	465/500		1.450

PERFORMANCE CURVES

► Typical Pressure Rise

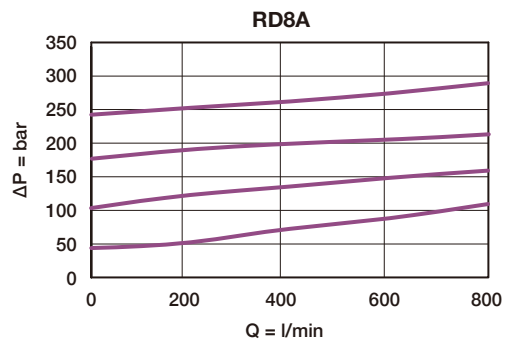
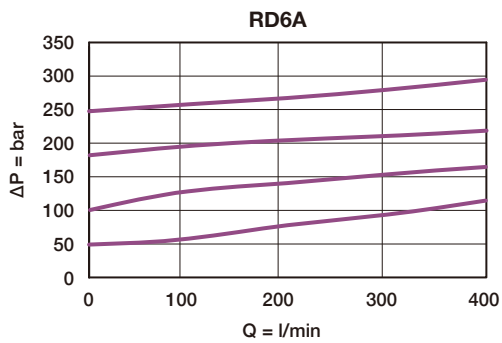
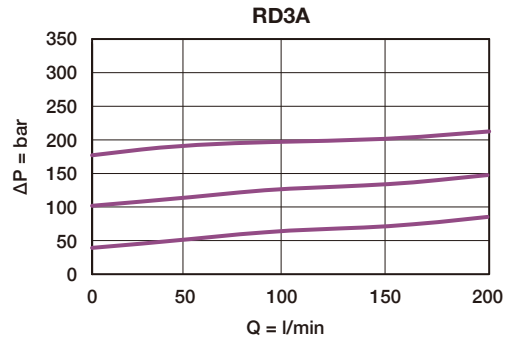
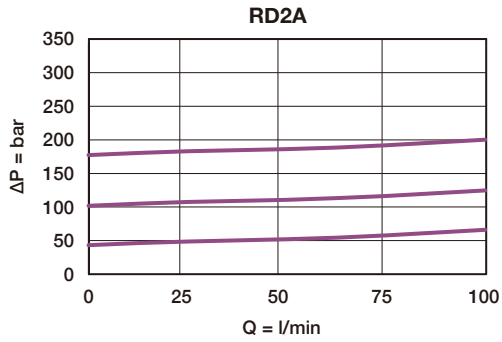
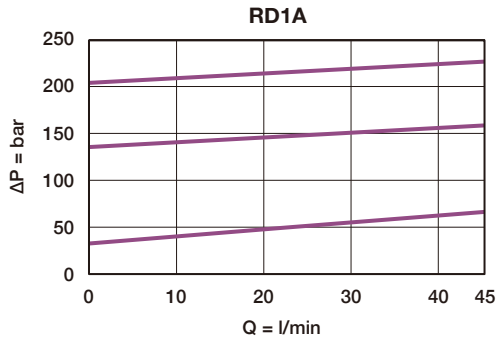

DIMENSION

(UNIT : mm)

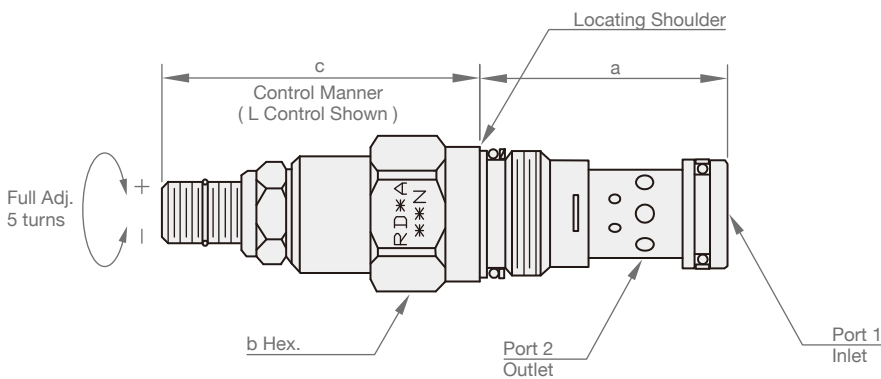

Model	a	b	c
			L
RD1A	30.2	18.62	54.1
RD2A	39.7	22.2	61
RD3A	47.8	28.6	64
RD6A	61.9	31.8	83
RD8A	79.4	41.3	100

RQ



SYMBOLS

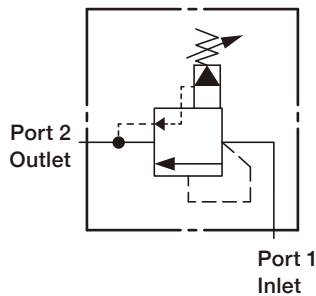

ORDER CODES

RQ **2B** - **T10A** - **L** **A** **N**

1 2 3 4 5 6

1	▶ Model Name	RQ	
2	▶ Valve Size	2B, 3B, 6B, 8B	
3	▶ Cavity	T10A, T3A, T16A, T18A	
4	▶ Control Manner	L	standard screw adjustment
		K	hand knob with lock knob
5	▶ Adjustable Range	A	7 ~ 210 bar
		B	3.5 ~ 105 bar
		C	10.5 ~ 420 bar
		N	5 ~ 55 bar
6	▶ Material of Seal	N	buna-N
		V	viton
		E	EPDM
		H	HNBR
		U	polyurethane

MODEL SPEC.

Model	Cavity	Capacity (l/min)	Max. Pressure (bar)	Installation Torque (Nm)	Operating Temperature	Weight (kg)
RQ2B	T10A	95	350	45/50	-35 ~ 100°C (-31 ~ 212°F)	0.14
RQ3B	T3A	200	350	60/70		0.26
RQ6B	T16A	380	350	200/215		0.54
RQ8B	T18A	760	350	465/500		1.17

PERFORMANCE CURVES

► Unloaded Pressure Drop

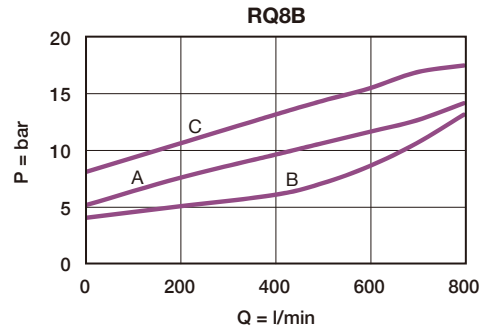
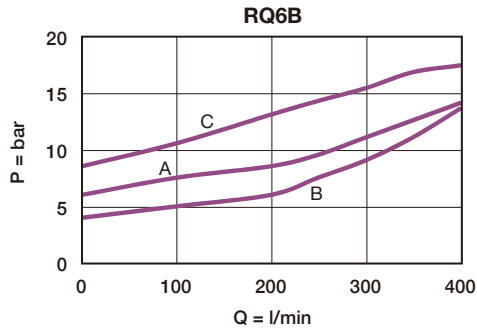
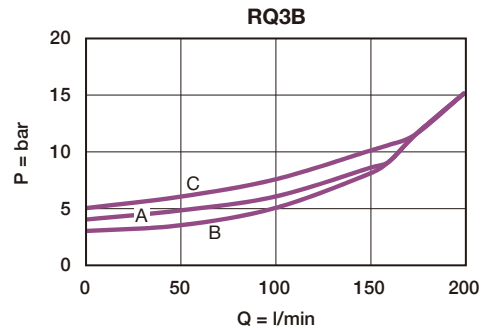
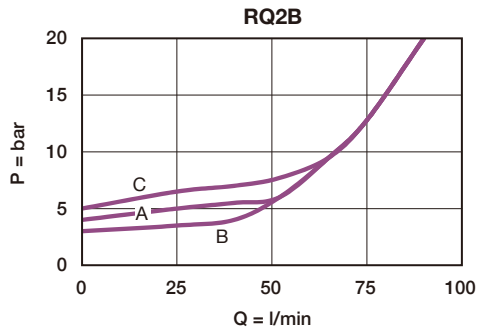

DIMENSION

(UNIT : mm)

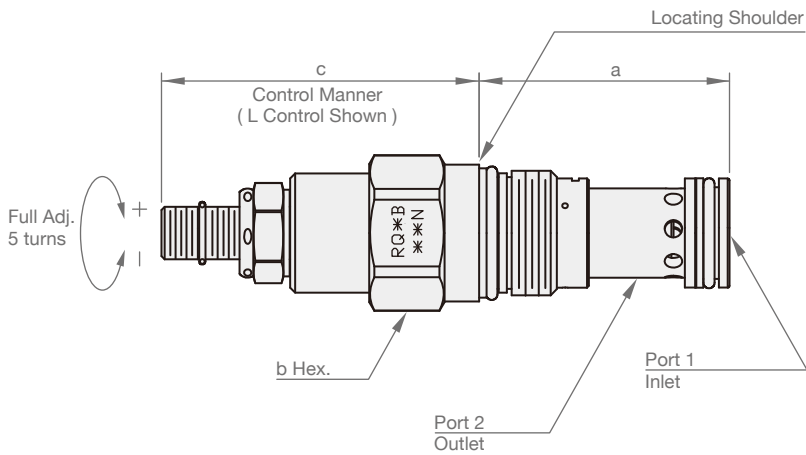

Model	a	b	c	
			L	K
RQ2B	39.6	22.2	50.8	57.2
RQ3B	47.8	28.6	53.8	60.5
RQ6B	62.0	31.8	62.0	68.3
RQ8B	79.5	41.3	71.4	77.7

RVA



SYMBOLS

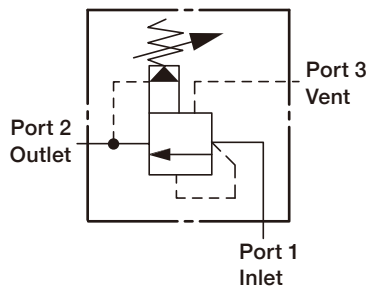

ORDER CODES

RV **2A** - **T11A** - **L** **A** **N**

① ② ③ ④ ⑤ ⑥

①	▶ Model Name	RV
②	▶ Valve Size	1A, 2A, 3A, 6A, 8A
③	▶ Cavity	T163A, T11A, T2A, T17A, T19A
④	▶ Control Manner	L standard screw adjustment
		K hand knob with lock knob
⑤	▶ Adjustable Range	A 7 ~ 210 bar
		B 3.5 ~ 105 bar
		C 10.5 ~ 420 bar
		N 5 ~ 55 bar
⑥	▶ Material of Seal	N buna-N
		V viton
		E EPDM
		H HNBR
		U polyurethane

MODEL SPEC.

Model	Cavity	Capacity (l/min)	Max. Pressure (bar)	Installation Torque (Nm)	Operating Temperature	Weight (kg)
RV1A	T163A	28.4	350	40/48	-35 ~ 100°C (-31 ~ 212°F)	0.12
RV2A	T11A	60	350	40/50		0.17
RV3A	T2A	120	350	60/70		0.30
RV6A	T17A	240	350	200/215		0.64
RV8A	T19A	480	350	465/500		1.43

PERFORMANCE CURVES

► Vented Pressure Drop

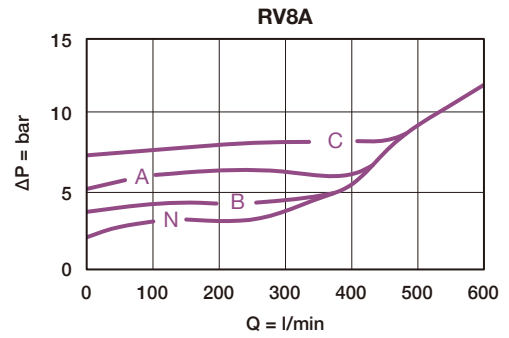
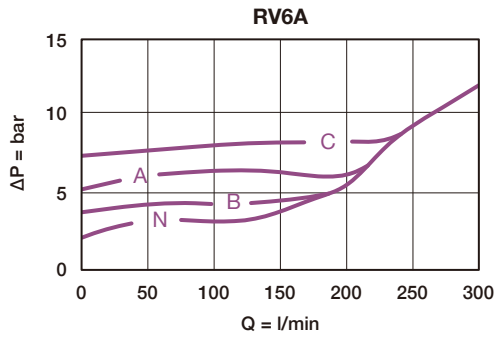
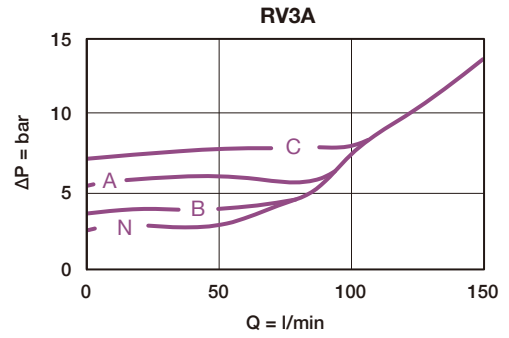
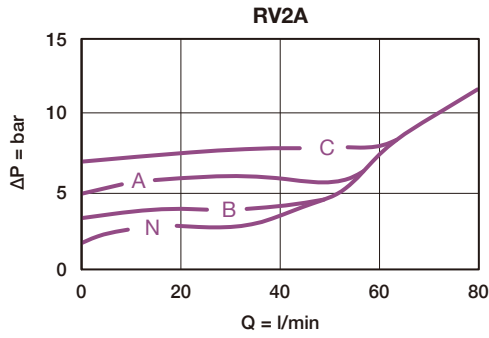
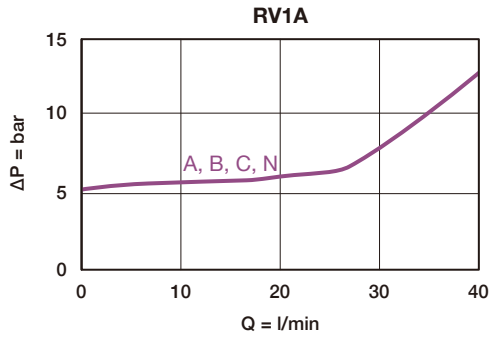

DIMENSION

(UNIT : mm)

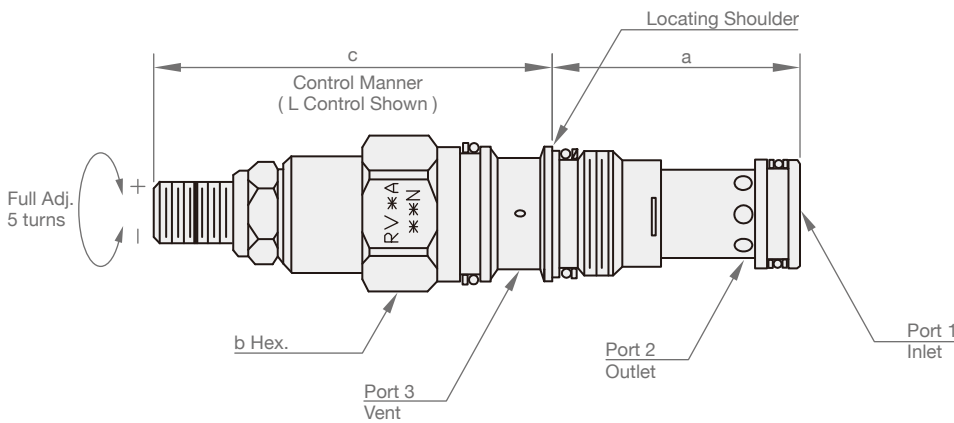

Model	a	b	c	
			L	K
RV1A	29.9	19	66	72
RV2A	34.9	22.2	64	70
RV3A	34.9	28.6	72	78
RV6A	46.0	31.8	84	90
RV8A	63.5	41.3	100	107

RVD



SYMBOLS

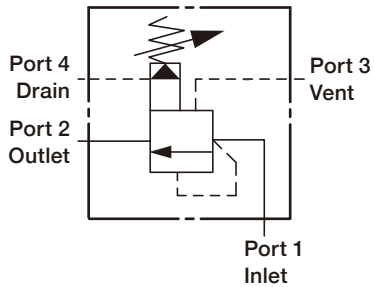

ORDER CODES

RV **2D** - **T21A** - **L** **A** **N**

1 2 3 4 5 6

1	▶ Model Name	RV
2	▶ Valve Size	2D, 3D, 6D, 8D
3	▶ Cavity	T21A, T22A, T23A, T24A
4	▶ Control Manner	L standard screw adjustment
		K hand knob with lock knob
5	▶ Adjustable Range	A 7 ~ 210 bar
		B 3.5 ~105 bar
		C 10.5 ~ 420 bar
		N 5 ~ 55 bar
6	▶ Material of Seal	N buna-N
		V viton
		E EPDM
		H HNBR
		U polyurethane

MODEL SPEC.

Model	Cavity	Capacity (l/min)	Max. Pressure (bar)	Installation Torque (Nm)	Operating Temperature	Weight (kg)
RV2D	T21A	60	350	45/50	-35 ~ 100°C (-31 ~ 212°F)	0.20
RV3D	T22A	120	350	60/70		0.35
RV6D	T23A	240	350	200/215		0.75
RV8D	T24A	480	350	465/500		1.75

PERFORMANCE CURVES

► Vented Pressure Drop

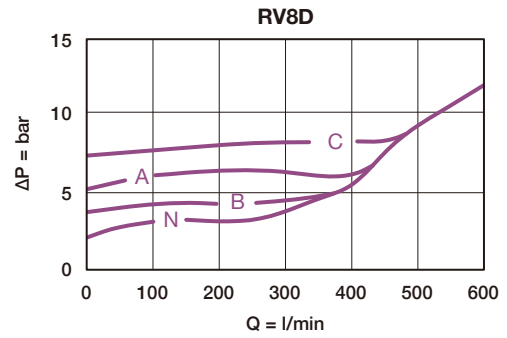
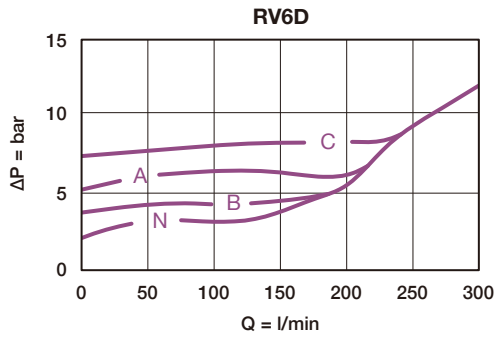
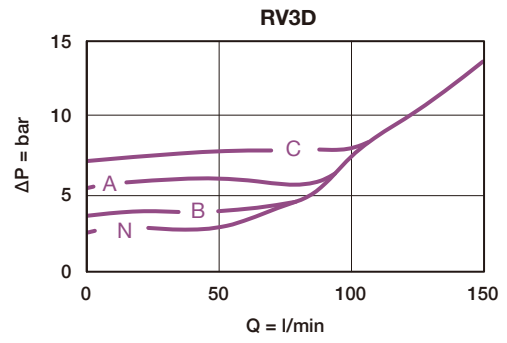
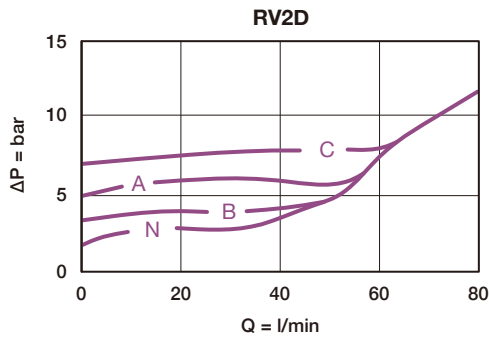

DIMENSION

(UNIT : mm)

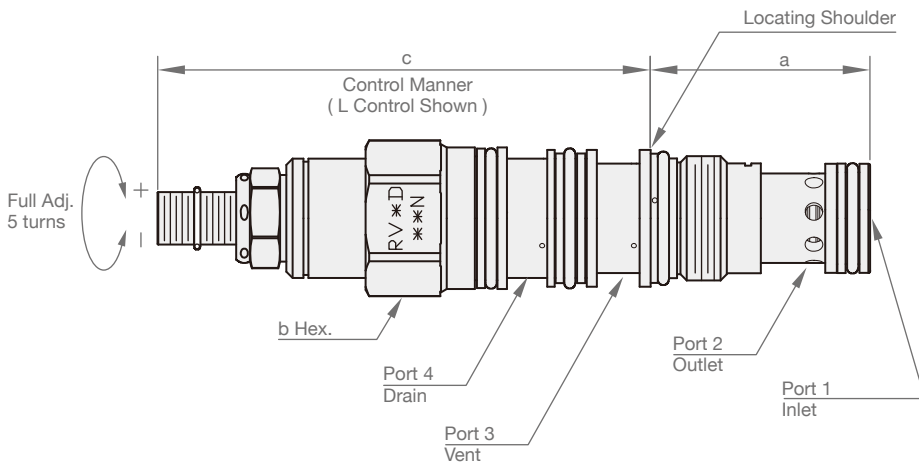

Model	a	b	c	
			L	K
RV2D	35.1	22.2	78.5	84.8
RV3D	35.1	28.6	87.4	93.7
RV6D	46.0	31.8	99.8	106.4
RV8D	63.5	41.3	121.4	127.8

RS



SYMBOLS

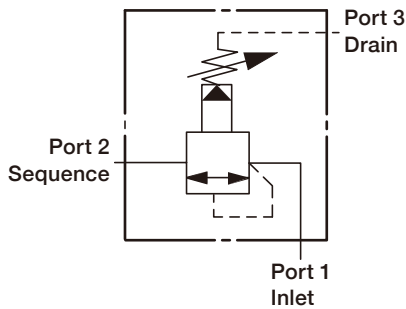

ORDER CODES

RS **2C** - **T11A** - **L** **A** **N**

1 2 3 4 5 6

1	Model Name	RS	
2	Valve Size	2C, 3C, 6C, 8C	
3	Cavity	T11A, T2A, T17A, T19A	
4	Control Manner	L	standard screw adjustment
		K	hand knob with lock knob
5	Adjustable Range	A	7 ~ 210 bar
		B	3.5 ~ 105 bar
		C	10.5 ~ 420 bar
		E	1.7 ~ 28 bar
		N	5 ~ 55 bar
		6	Material of Seal
		V	viton
		E	EPDM
		H	HNBR
		U	polyurethane

MODEL SPEC.

Model	Cavity	Capacity (l/min)	Max. Pressure (bar)	Installation Torque (Nm)	Operating Temperature	Weight (kg)
RS2C	T11A	60	350	40/50	-35 ~ 100°C (-31 ~ 212°F)	0.17
RS3C	T2A	120	350	60/70		0.30
RS6C	T17A	240	350	200/215		0.64
RS8C	T19A	480	350	465/500		1.43

PERFORMANCE CURVES

► Pressure Drop Fully Sequence

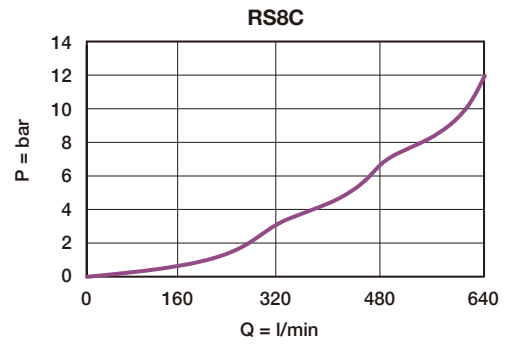
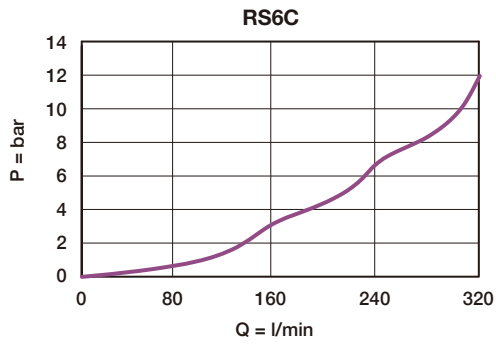
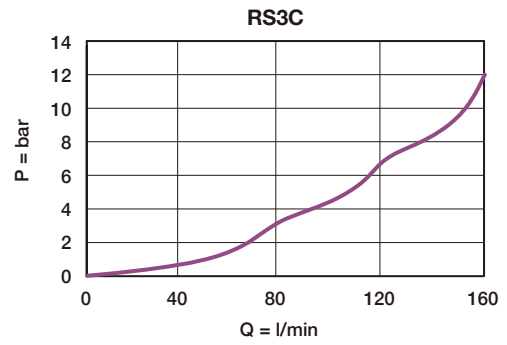
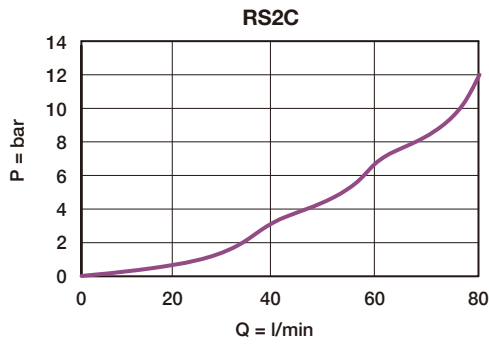

DIMENSION

(UNIT : mm)

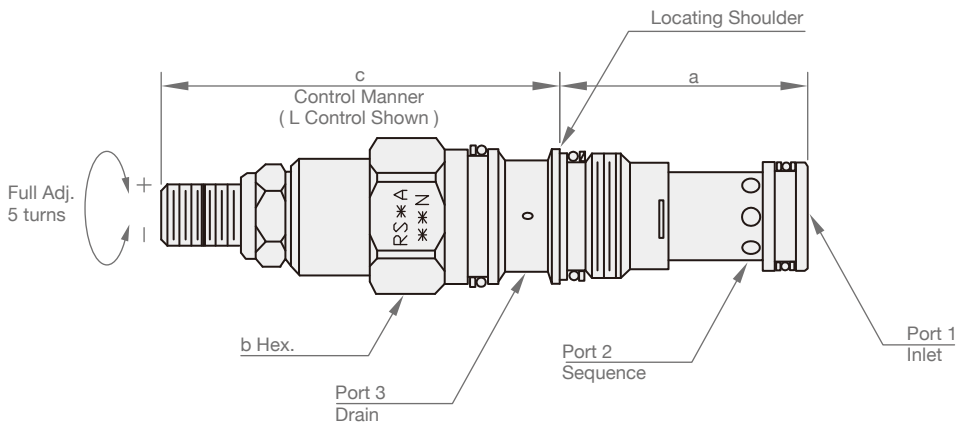

Model	a	b	c	
			L	K
RS2C	34.9	22.2	64	70
RS3C	34.9	28.6	72	78
RS6C	46.0	31.8	84	90
RS8C	63.5	41.3	100	107

SQ



SYMBOLS

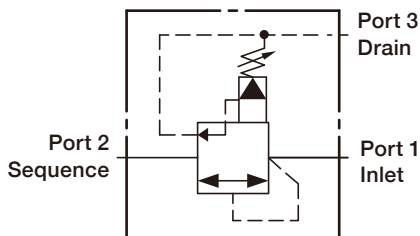

ORDER CODES

SQ **2B** - **T11A** - **L** **A** **N**

1 2 3 4 5 6

1	Model Name	SQ	
2	Valve Size	2C, 3C, 6C, 8C	
3	Cavity	T11A, T2A, T17A, T19A	
4	Control Manner	L	standard screw adjustment
		K	hand knob with lock knob
5	Adjustable Range	A	7 ~ 210 bar
		B	3.5 ~ 105 bar
		C	10 ~ 400 bar
		N	5 ~ 55 bar
6	Material of Seal	N	buna-N
		V	viton
		E	EPDM
		H	HNBR
		U	polyurethane

MODEL SPEC.

Model	Cavity	Capacity (l/min)	Max. Pressure (bar)	Installation Torque (Nm)	Operating Temperature	Weight (kg)
SQ2B	T11A	60	350	40/50	-35 ~ 100°C (-31 ~ 212°F)	0.17
SQ3B	T2A	120	350	60/70		0.30
SQ6B	T17A	240	350	200/215		0.64
SQ8B	T19A	480	350	465/500		1.43

PERFORMANCE CURVES

► Pressure Drop After Opening

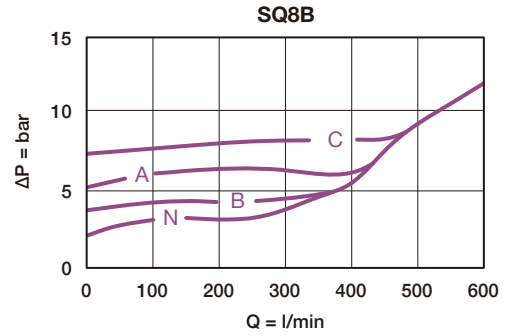
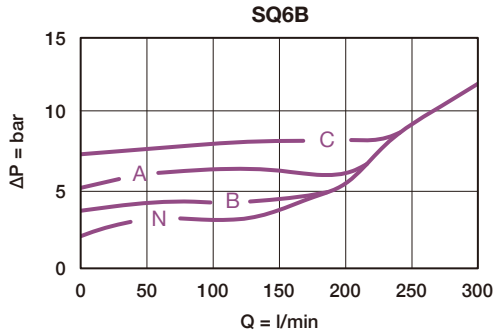
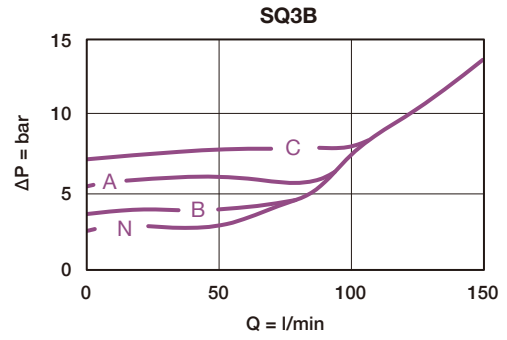
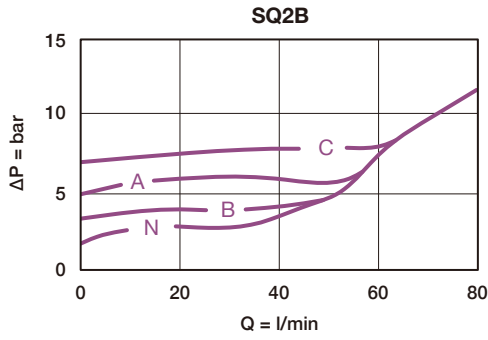

DIMENSION

(UNIT : mm)

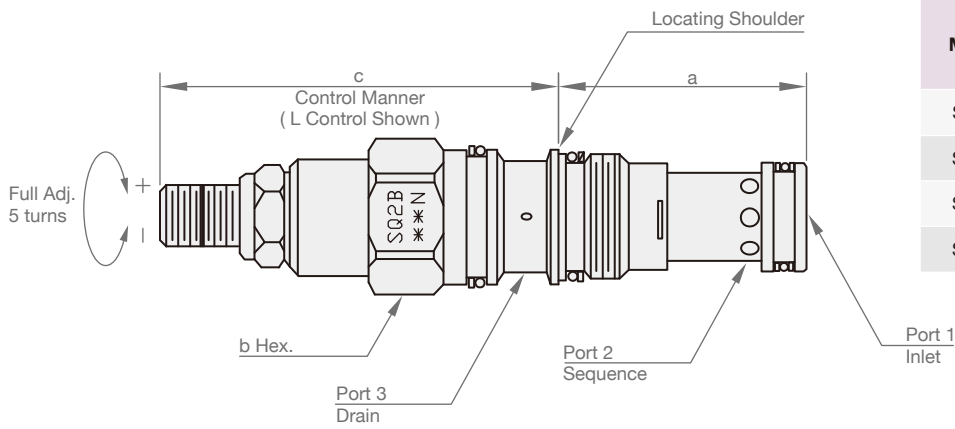

Model	a	b	c	
			L	K
SQ2B	34.9	22.2	64	70
SQ3B	34.9	28.6	72	78
SQ6B	46.0	31.8	84	90
SQ8B	63.5	41.3	100	107

SC



SYMBOLS

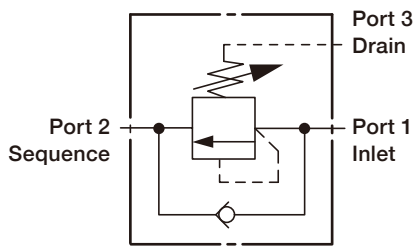

ORDER CODES

SC **2A** - **T11A** - **L** **A** **N**

1 2 3 4 5 6

1	Model Name	SC	
2	Valve Size	2A, 3A, 6A, 8A	
3	Cavity	T11A, T2A, T17A, T19A	
4	Control Manner	L	standard screw adjustment
		K	hand knob with lock knob
5	Adjustable Range	A	35 ~ 210 bar
		B	20 ~ 105 bar
		C	140 ~ 420 bar
		D	14 ~ 55 bar
6	Material of Seal	N	buna-N
		V	viton
		E	EPDM
		H	HNBR
		U	polyurethane

MODEL SPEC.

Model	Cavity	Capacity (l/min)	Max. Pressure (bar)	Installation Torque (Nm)	Operating Temperature	Weight (kg)
SC2A	T11A	60	350	45/50	-35 ~ 100°C (-31 ~ 212°F)	0.20
SC3A	T2A	120	350	60/70		0.38
SC6A	T17A	240	350	200/215		0.74
SC8A	T19A	480	350	465/500		1.62

PERFORMANCE CURVES

► Free Flow & Pressure Drop Fully Sequenced

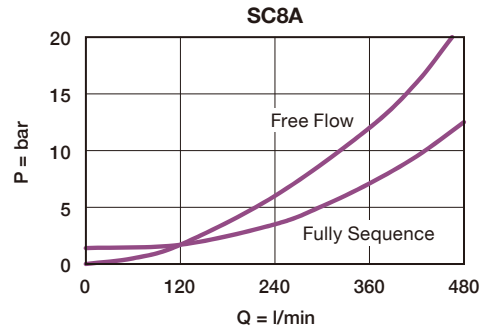
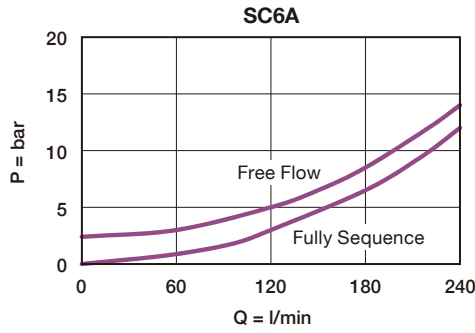
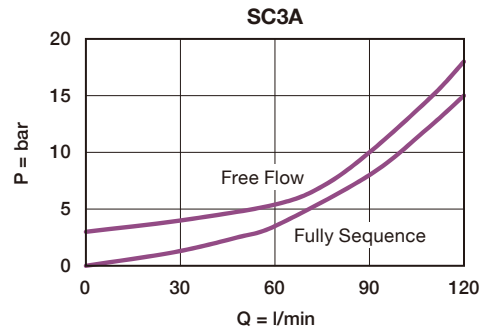
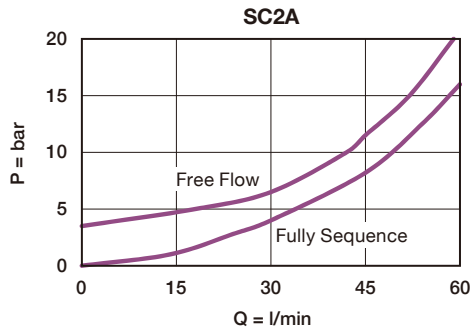

DIMENSION

(UNIT : mm)

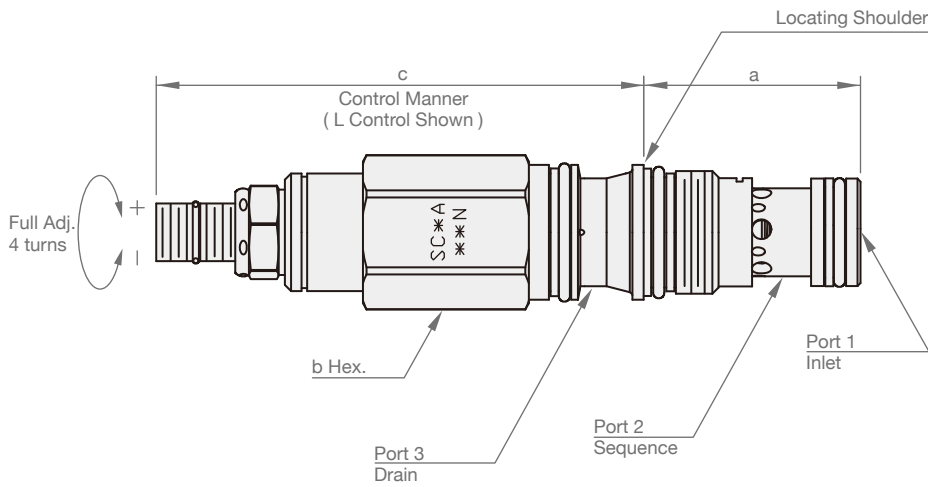

Model	a	b	c	
			L	K
SC2A	35.1	22.2	78.5	84.8
SC3A	35.1	28.6	88.1	94.0
SC6A	46.0	31.8	100.0	-
SC8A	63.5	41.3	122.9	-

SX



SYMBOLS

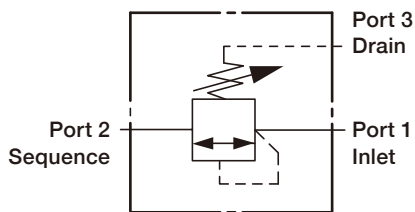

ORDER CODES

SX **3A** - **T11A** - **L** **A** **N**

1 2 3 4 5 6

1	▶ Model Name	SX	
2	▶ Valve Size	2A, 3A	
3	▶ Cavity	T11A, T2A	
4	▶ Control Manner	L	standard screw adjustment
		K	hand knob with lock knob
5	▶ Adjustable Range	A	35 ~ 210 bar
		B	20 ~105 bar
		C	140 ~ 420 bar
		D	14 ~ 55 bar
6	▶ Material of Seal	N	buna-N
		V	viton
		E	EPDM
		H	HNBR
		U	polyurethane

MODEL SPEC.

Model	Cavity	Capacity (l/min)	Max. Pressure (bar)	Installation Torque (Nm)	Operating Temperature	Weight (kg)
SX2A	T11A	60	350	45/50	-35 ~ 100°C (-31 ~ 212°F)	0.20
SX3A	T2A	120	350	60/70		0.36

PERFORMANCE CURVES

► Pressure Drop Fully Sequenced

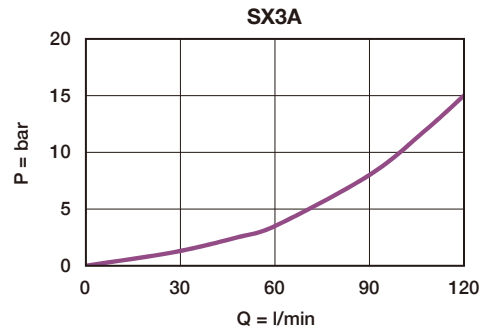
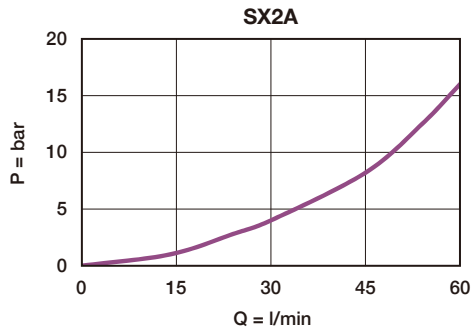

DIMENSION

(UNIT : mm)

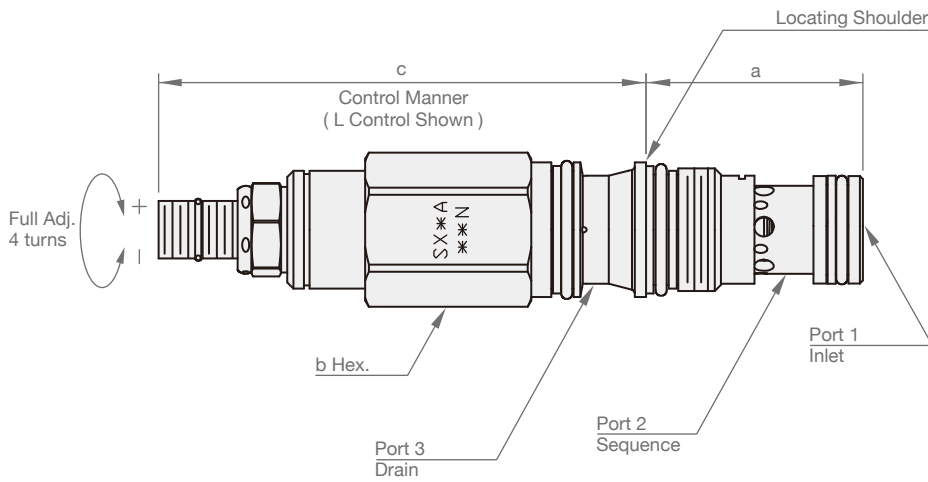

Model	a	b	c	
			L	K
SX2A	35.1	22.2	78.5	84.8
SX3A	35.1	28.6	88.1	94.0

PB



SYMBOLS

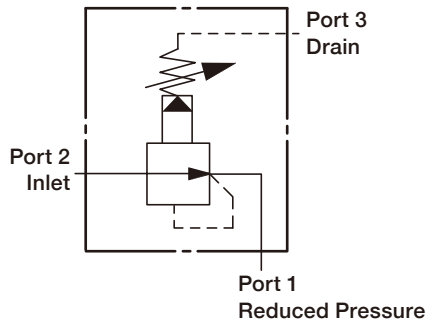

ORDER CODES

PB **2B** - **T11A** - **L** **A** **N**

① ② ③ ④ ⑤ ⑥

① ▶	Model Name	PB	
② ▶	Valve Size	2B, 3B, 6B, 8B	
③ ▶	Cavity	T11A, T2A, T17A, T19A	
④ ▶	Control Manner	L	standard screw adjustment
		K	hand knob with lock knob
⑤ ▶	Adjustable Range	A	7 ~ 210 bar
		B	3.5 ~105 bar
		C	10.5~420 bar
		N	4~55 bar
⑥ ▶	Material of Seal	N	buna-N
		V	viton
		E	EPDM
		H	HNBR
		U	polyurethane

MODEL SPEC.

Model	Cavity	Capacity (l/min)	Max. Pressure (bar)	Installation Torque (Nm)	Operating Temperature	Weight (kg)
PB2B	T11A	40	350	40/50	-35 ~ 100°C (-31 ~ 212°F)	0.17
PB3B	T2A	80	350	60/70		0.30
PB6B	T17A	160	350	200/215		0.64
PB8B	T19A	320	350	465/500		1.43

PERFORMANCE CURVES

► No Load Pressure Drop

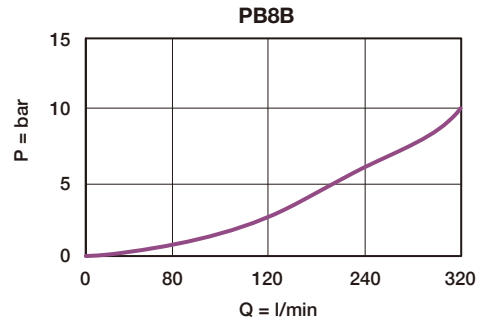
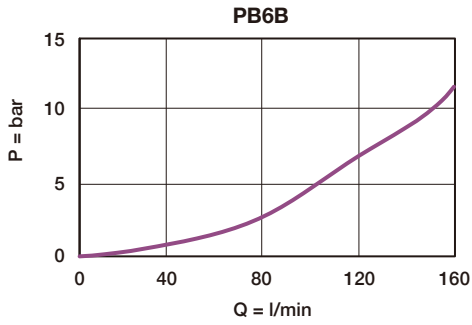
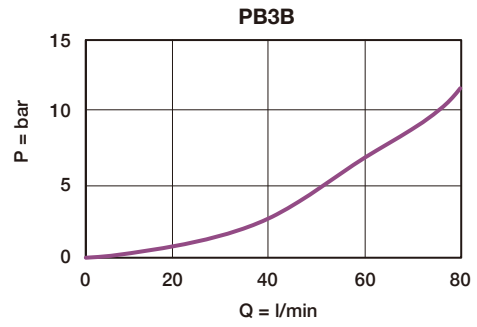
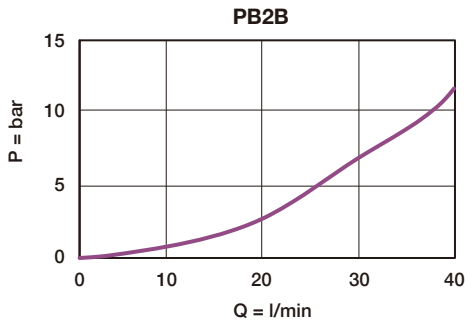

DIMENSION

(UNIT : mm)

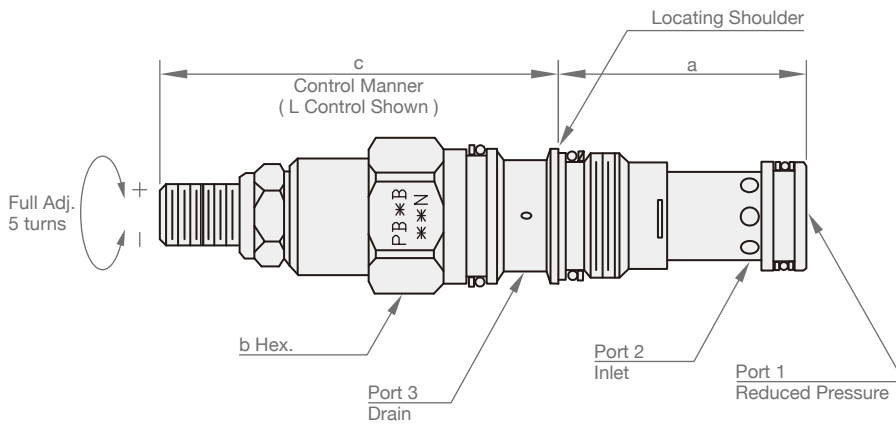

Model	a	b	c	
			L	K
PB2B	34.9	22.2	64	70
PB3B	34.9	28.6	72	78
PB6B	46.0	31.8	84	90
PB8B	63.5	41.3	100	107

PRP



SYMBOLS

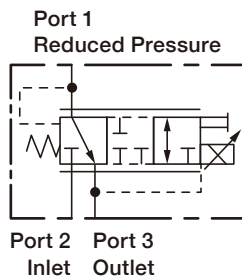

ORDER CODES

PR 2 P - T11A - M D N - DR 24

1 2 1 3 4 5 6 7 8

1	▶ Model Name	PRP	
2	▶ Capacity (l/min)	2	20
3	▶ Cavity	T11A	
4	▶ Control Manner	M	manual override
5	▶ Adjustment Range (bar)	D	3.5 ~ 33.5
6	▶ Material of Seal	N	buna-N
		V	viton
		E	EPDM
		H	HNBR
		U	polyurethane
7	▶ Connector (coil)	DG	ISO/DIN43650
		DR	Deutsch DT04-2P
8	▶ Voltage (coil)	12	12 VDC
		24	24 VDC

MODEL SPEC.

Model	Cavity	Capacity (l/min)	Max. Pressure (bar)	Leakage	Installation Torque (Nm)
PR2P	T11A	20	350	less than 45 cc/min	40/50
Model	Max. Current	Power Consumption (watts)	Body's Weight (kg)	Coil's Weight (kg)	
PR2P	1820mA@12VDC 910mA@24VDC	22	0.33	0.23	

PERFORMANCE CURVES

► Pressure vs. Command

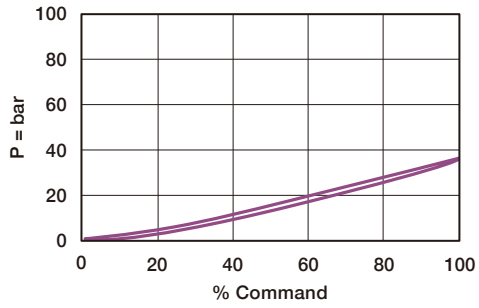

DIMENSION

(UNIT : mm)

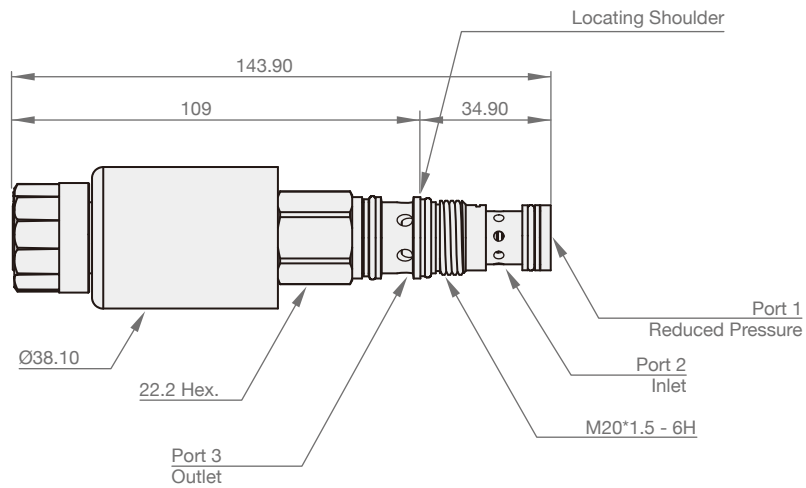

PRL



SYMBOLS

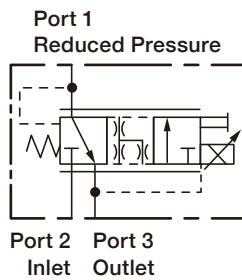

ORDER CODES

PR 2 L - T11A - M D N - DG 24

1 2 1 3 4 5 6 7 8

1	▶ Model Name	PRL	
2	▶ Capacity (l/min)	2	20
3	▶ Cavity	T11A	
4	▶ Control Manner	M	manual override
5	▶ Adjustment Range (bar)	D	3.5 ~ 33.5
6	▶ Material of Seal	N	buna-N
		V	viton
		E	EPDM
		H	HNBR
		U	polyurethane
7	▶ Connector (coil)	DG	ISO/DIN43650
		DR	Deutsch DT04-2P
8	▶ Voltage (coil)	12	12 VDC
		24	24 VDC

MODEL SPEC.

Model	Cavity	Capacity (l/min)	Max. Pressure (bar)	Leakage	Installation Torque (Nm)
PR2L	T11A	20	350	less than 330 cc/min	40/50
Model	Max. Current	Power Consumption (watts)	Body's Weight (kg)	Coil's Weight (kg)	
PR2L	1820mA@12VDC 910mA@24VDC	22	0.33	0.23	

PERFORMANCE CURVES

► Pressure vs. Command

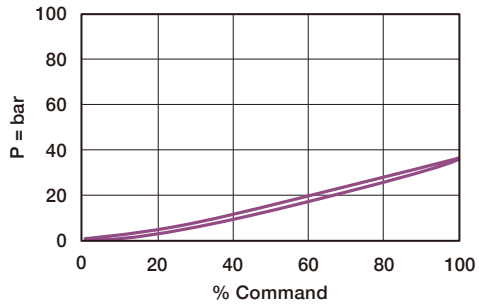

DIMENSION

(UNIT : mm)

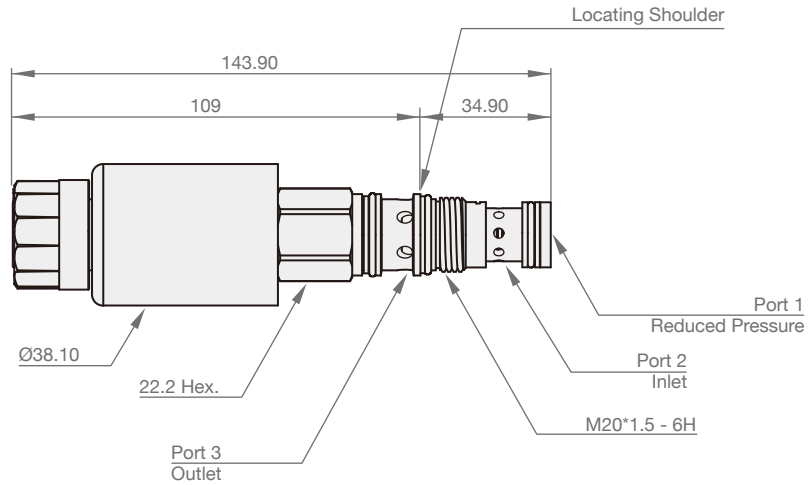

PP



SYMBOLS

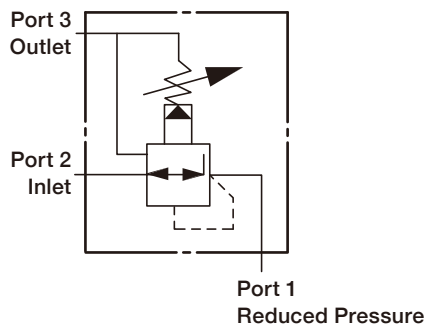

ORDER CODES

PP **2B** - **T11A** - **L** **A** **N**

① ② ③ ④ ⑤ ⑥

① ▶	Model Name	PP	
② ▶	Valve Size	2B, 3B, 6B, 8B	
③ ▶	Cavity	T11A, T2A, T17A, T19A	
④ ▶	Control Manner	L	standard screw adjustment
		K	hand knob with lock knob
		A	7 ~ 210 bar
⑤ ▶	Adjustable Range	B	3.5 ~105 bar
		C	10.5 ~ 420 bar
		N	4 ~ 55 bar
		N	4 ~ 55 bar
⑥ ▶	Material of Seal	N	buna-N
		V	viton
		E	EPDM
		H	HNBR
		U	polyurethane

MODEL SPEC.

Model	Cavity	Capacity (l/min)	Max. Pressure (bar)	Installation Torque (Nm)	Operating Temperature	Weight (kg)
PP2B	T11A	40	350	40/50	-35 ~ 100°C (-31 ~ 212°F)	0.17
PP3B	T2A	80	350	60/70		0.30
PP6B	T17A	160	350	200/215		0.64
PP8B	T19A	320	350	465/500		1.43

PERFORMANCE CURVES

► Regulated Pressure

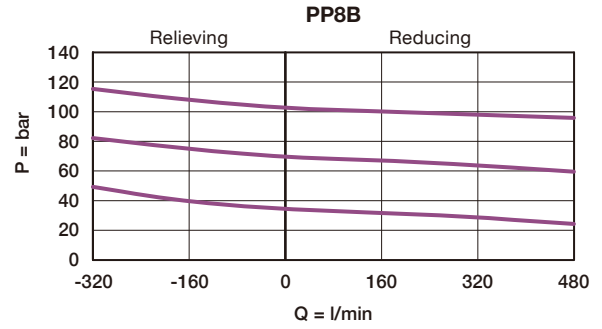
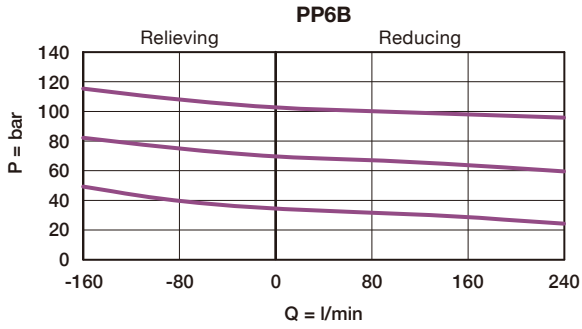
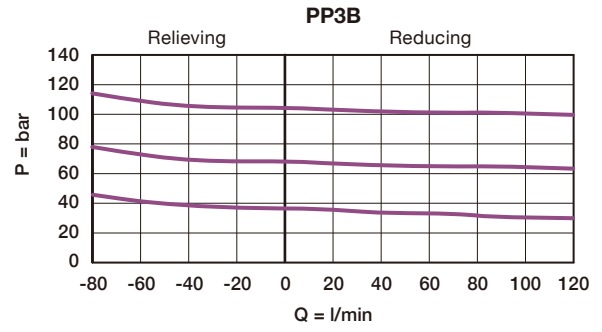
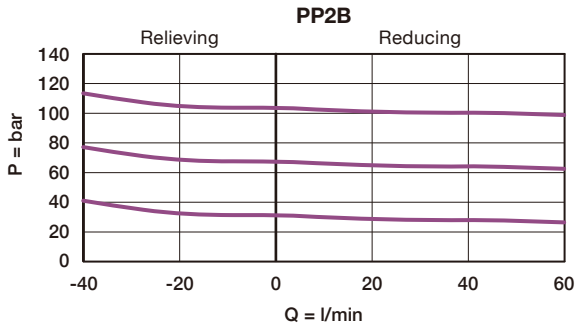

DIMENSION

(UNIT : mm)

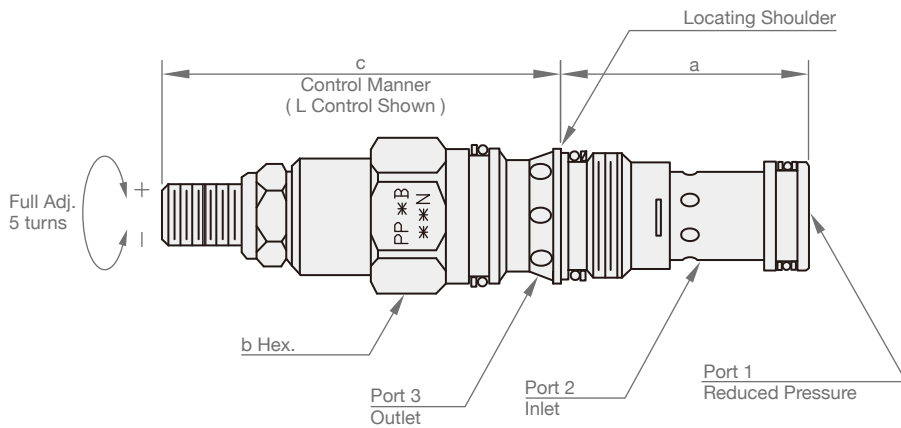

Model	a	b	c	
			L	K
PP2B	34.9	22.2	64	70
PP3B	34.9	28.6	72	78
PP6B	46.0	31.8	84	90
PP8B	63.5	41.3	100	107

PRB



SYMBOLS

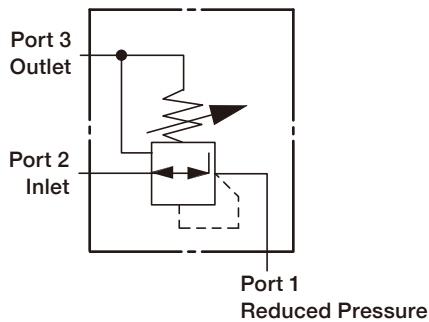

ORDER CODES

PR 2 B - T11A - L A N

1 2 1 3 4 5 6

1	▶ Model Name	PRB	
2	▶ Valve Size	2, 3, 6, 8	
3	▶ Cavity	T11A, T2A, T17A, T19A	
4	▶ Control Manner	L	standard screw adjustment
		K	hand knob with lock knob
5	▶ Adjustable Range	A	35 ~ 210 bar
		B	3.5 ~ 105 bar
		D	1.7 ~ 55 bar
		W	50 ~ 315 bar
6	▶ Material of Seal	N	buna-N
		V	viton
		E	EPDM
		H	HNBR
		U	polyurethane

MODEL SPEC.

Model	Cavity	Capacity (l/min)	Max. Pressure (bar)	Installation Torque (Nm)	Operating Temperature	Weight (kg)
PR2B	T11A	40	350	40/50	-35 ~ 100°C (-31 ~ 212°F)	0.20
PR3B	T2A	80	350	60/70		0.36
PR6B	T17A	160	350	200/215		0.76
PR8B	T19A	320	350	465/500		1.58

PERFORMANCE CURVES

► Regulated Pressure

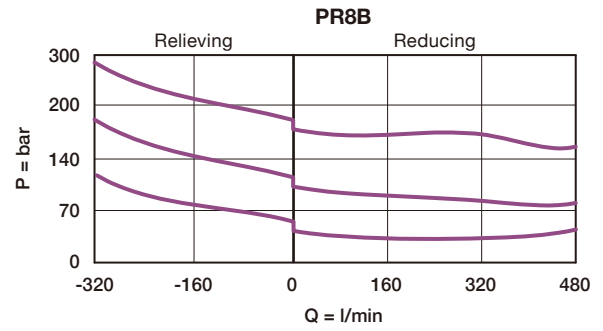
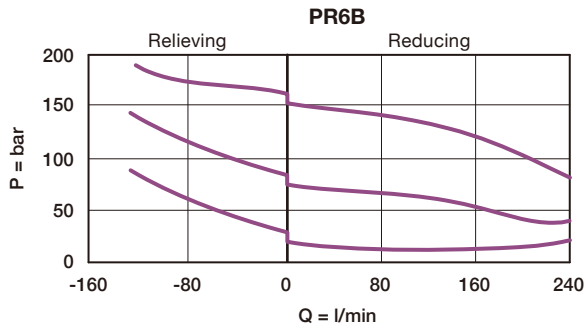
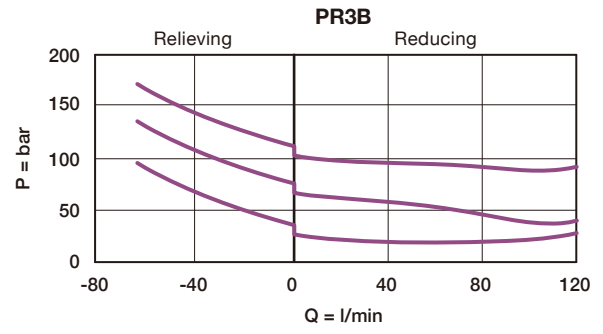
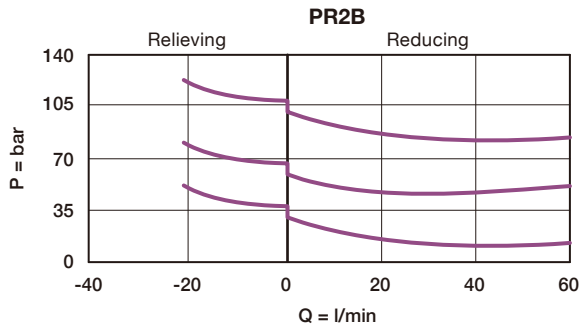

DIMENSION

(UNIT : mm)

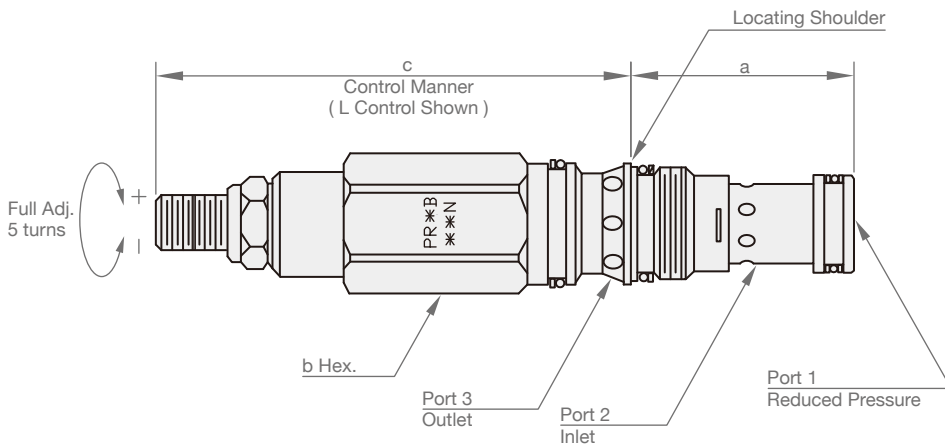

Model	a	b	c	
			L	K
PR2B	34.9	22.2	79	85
PR3B	34.9	28.6	89	96
PR6B	46.0	31.8	100	107
PR8B	63.5	41.3	124	130

FPC



SYMBOLS

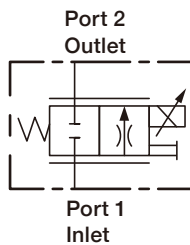

ORDER CODES

FP 2 C - T13A - M C N - DR 24

① ② ③ ④ ⑤ ⑥ ⑦ ⑧

① ▶ Model Name	FPC	normally closed
② ▶ Capacity (l/min)	2	40
③ ▶ Cavity	T13A	
④ ▶ Control Manner	M	manual override
⑤ ▶ Flow Range (l/min)	C	1 ~ 28
⑥ ▶ Material of Seal	N	buna-N
	V	viton
	E	EPDM
	H	HNBR
	U	polyurethane
⑦ ▶ Connector (coil)	DG	ISO/DIN43650
	DR	Deutsch DT04-2P
⑧ ▶ Voltage (coil)	12	12 VDC
	24	24 VDC

MODEL SPEC.

Model	Cavity	Capacity (l/min)	Max. Pressure (bar)	Leakage	Installation Torque (Nm)
FP2C	T13A	40	350	less than 100 cc/min	45/50
Model	Hysteresis	Max. Current	Power Consumption (watts)	Body's Weight (kg)	Coil's Weight (kg)
FP2C	5%	1820mA@12VDC 910mA@24VDC	22	0.27	0.23

PERFORMANCE CURVES

► Flow vs. Command @14bar

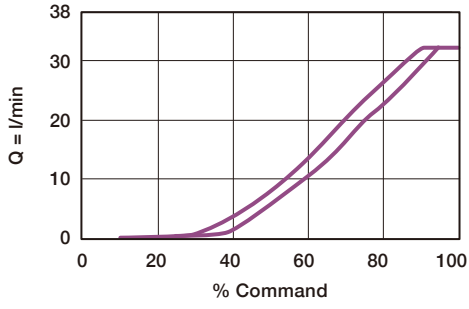

► Flow vs. Pressure Differential

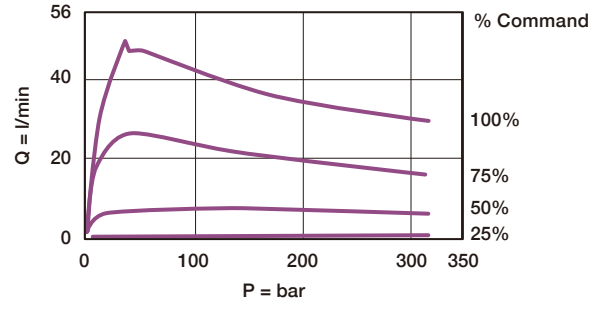

DIMENSION

(UNIT : mm)

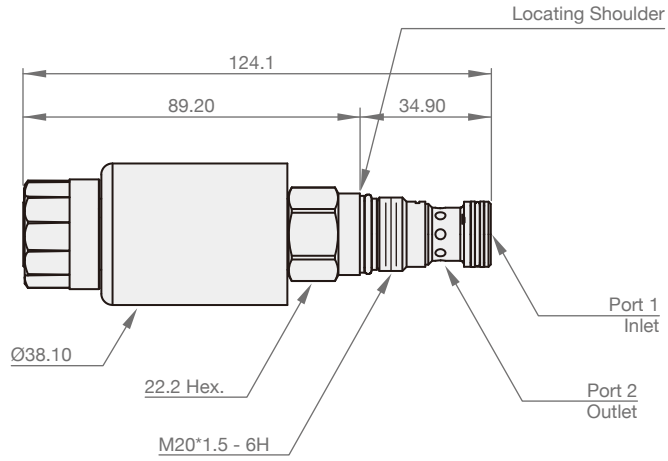

FPH



SYMBOLS

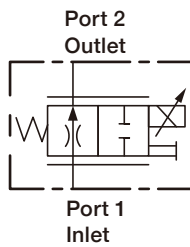

ORDER CODES

FP 2 H - T13A - M C N - DG 24

1 2 1 3 4 5 6 7 8

1	▶ Model Name	FPH	normally open
2	▶ Capacity (l/min)	2	28
3	▶ Cavity	T13A	
4	▶ Control Manner	M	manual override
5	▶ Flow Range (l/min)	C	1 ~ 28
6	▶ Material of Seal	N	buna-N
		V	viton
		E	EPDM
		H	HNBR
		U	polyurethane
7	▶ Connector (coil)	DG	ISO/DIN43650
		DR	Deutsch DT04-2P
8	▶ Voltage (coil)	12	12 VDC
		24	24 VDC

MODEL SPEC.

Model	Cavity	Capacity (l/min)	Max. Pressure (bar)	Leakage	Installation Torque (Nm)
FP2H	T13A	28	350	less than 100 cc/min	45/50
Model	Hysteresis	Max. Current	Power Consumption (watts)	Body's Weight (kg)	Coil's Weight (kg)
FP2H	5%	1820mA@12VDC 910mA@24VDC	22	0.27	0.23

PERFORMANCE CURVES

► Flow vs. Command @14bar

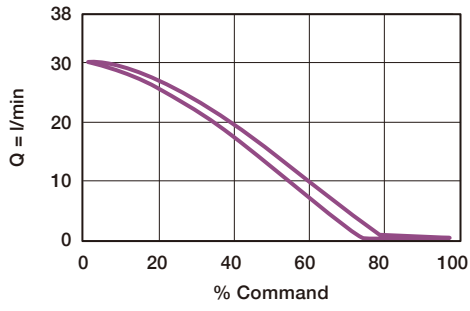

► Flow vs. Pressure Differential

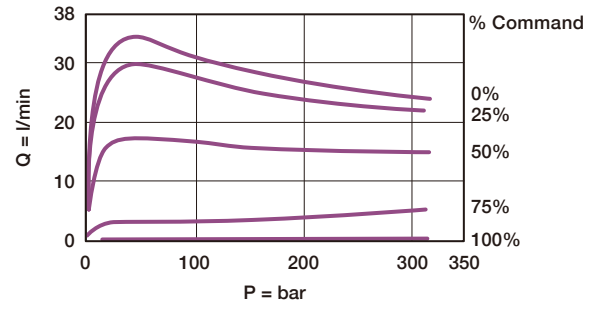

DIMENSION

(UNIT : mm)

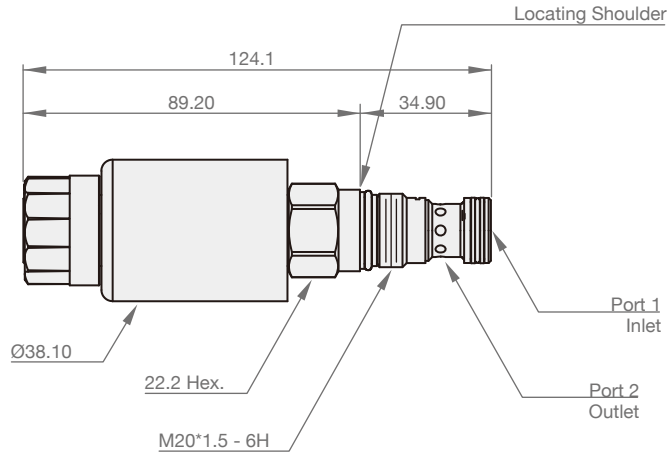

FMA



SYMBOLS

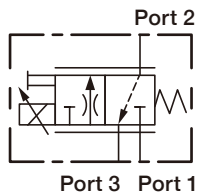

ORDER CODES

FM **2** **A** - **T11A** - **M** **D** **N** - **DG** **24**

1 2 1 3 4 5 6 7 8

1	▶ Model Name	FMA	
2	▶ Capacity (l/min)	2	34
3	▶ Cavity	T11A	
4	▶ Control Manner	M	manual override
5	▶ Flow Range (l/min)	D	0.4 ~ 34
6	▶ Material of Seal	N	buna-N
		V	viton
		E	EPDM
		H	HNBR
		U	polyurethane
7	▶ Connector (coil)	DG	ISO/DIN43650
		DR	Deutsch DT04-2P
8	▶ Voltage (coil)	12	12 VDC
		24	24 VDC

MODEL SPEC.

Model	Cavity	Capacity (l/min)	Max. Pressure (bar)	Leakage	Installation Torque (Nm)
FM2A	T11A	34	350	less than 100 cc/min	40/50
Model	Hysteresis	Max. Current	Power Consumption (watts)	Body's Weight (kg)	Coil's Weight (kg)
FM2A	5%	1820mA@12VDC 910mA@24VDC	22	0.28	0.23

PERFORMANCE CURVES

► Flow vs. Command

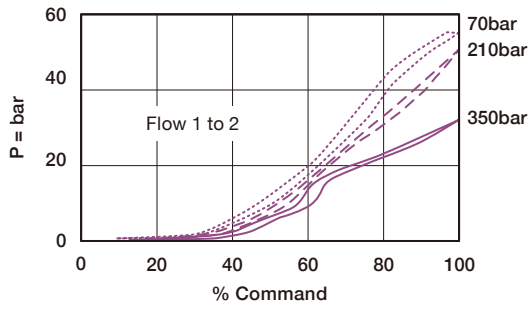

► Pressure vs. Flow

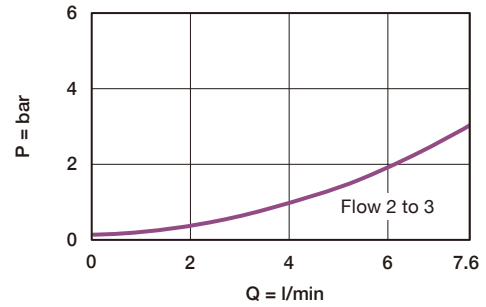
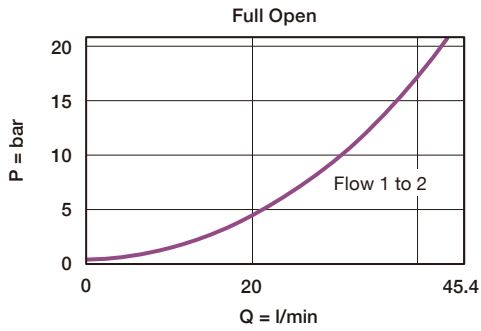

DIMENSION

(UNIT : mm)

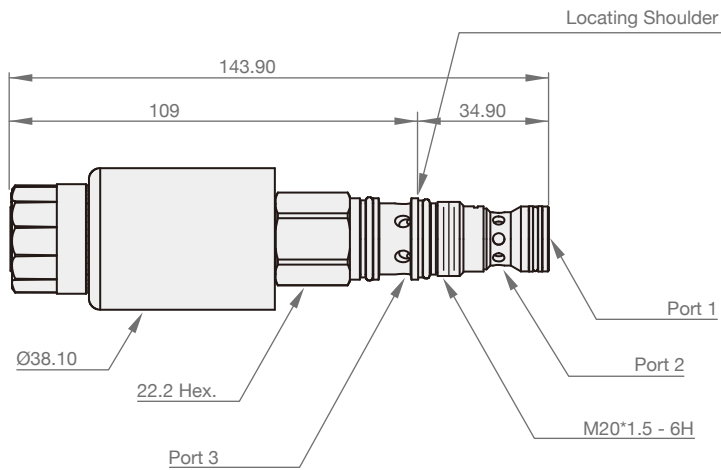

NFC



SYMBOLS

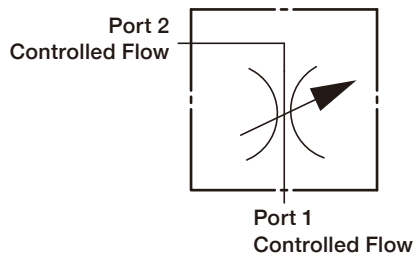

ORDER CODES

NF **2C** - **T13A** - **L** **C** **N**

1 2 3 4 5 6

1	▶ Model Name	NF	
2	▶ Valve Size	1C, 2C, 3C, 6C, 8C	
3	▶ Cavity	T162A, T13A, T5A, T16A, T18A	
4	▶ Control Manner	L	standard screw adjustment
		K	hand knob with lock knob
5	▶ Max. Orifice	C	T162A : 4mm, T13A : 4.8mm
		A	T5A : 6.3mm
		E	T16A : 9.6mm
		G	T18A : 14.2mm
6	▶ Material of Seal	N	buna-N
		V	viton
		E	EPDM
		H	HNBR
		U	polyurethane

MODEL SPEC.

Model	Cavity	Capacity (l/min)	Max. Pressure (bar)	Installation Torque (Nm)	Operating Temperature	Weight (kg)
NF1C	T162A	18.9	350	40/50	-35 ~ 100°C (-31 ~ 212°F)	0.07
NF2C	T13A	25	350	40/50		0.14
NF3C	T5A	50	350	60/70		0.26
NF6C	T16A	100	350	200/215		0.55
NF8C	T18A	200	350	465/500		1.21

PERFORMANCE CURVES

► Adjustment Sensitivity at 7 bar Differential

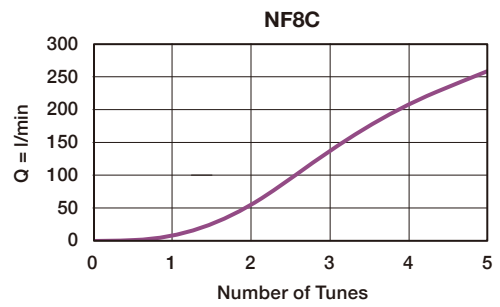
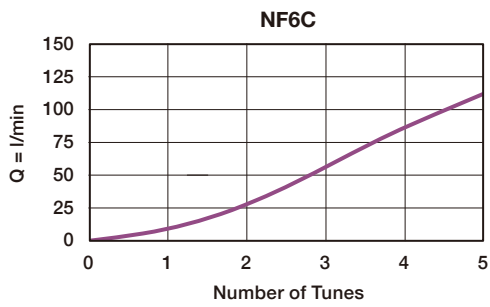
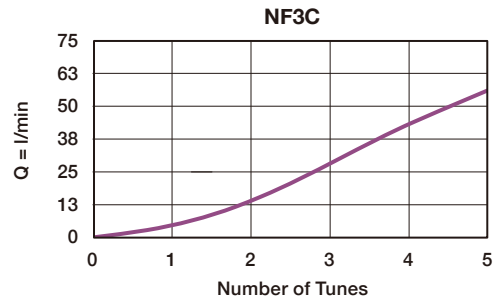
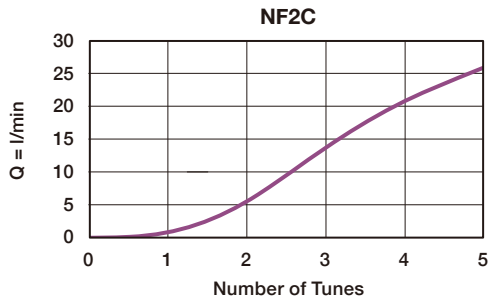
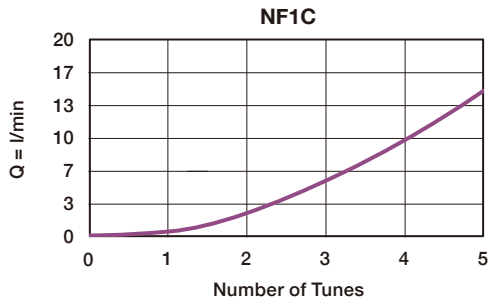

DIMENSION

(UNIT : mm)

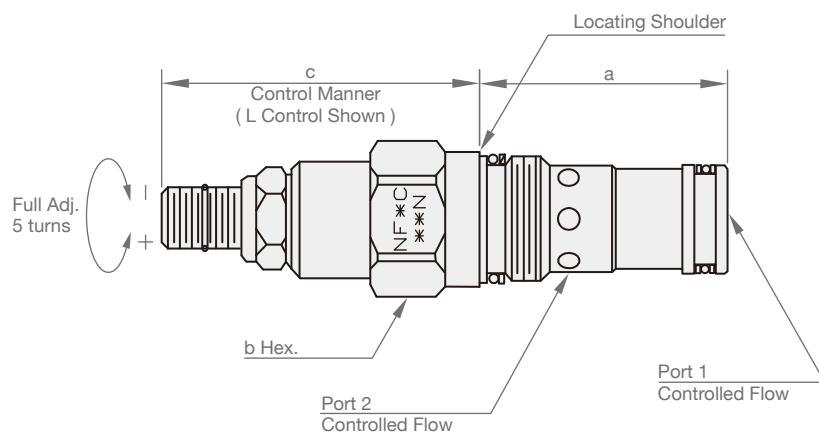

Model	a	b	c	
			L	K
NF1C	30	19	24.8	30.8
NF2C	34.9	22.2	58	64
NF3C	41.1	28.6	67	73
NF6C	61.9	31.8	73	79
NF8C	79.4	41.3	84	90

NFD



SYMBOLS

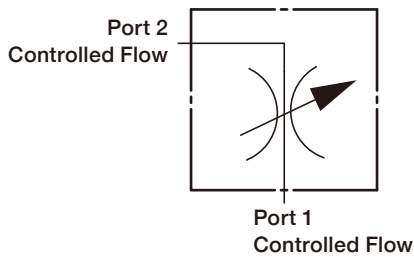

ORDER CODES

NF 2 D - T13A - L F N

1 2 3 4 5 6 7

1	▶ Model Name	NF	
2	▶ Valve Size	2, 3, 6, 8	
3	▶ Operation	D	high capacity
4	▶ Cavity	T13A, T5A, T16A, T18A	
5	▶ Control Manner	L	standard screw adjustment
		K	hand knob with lock knob
6	▶ Max. Orifice	F	T13A : 8.4mm
		G	T5A : 12.7mm
		H	T16A : 17.5mm
		I	T18A : 21.6mm
7	▶ Material of Seal	N	buna-N
		V	viton
		E	EPDM
		H	HNBR
		U	polyurethane

MODEL SPEC.

Model	Cavity	Capacity (l/min)	Max. Pressure (bar)	Installation Torque (Nm)	Operating Temperature	Weight (kg)
NF2D	T13A	80	350	40/50	-35 ~ 100°C (-31 ~ 212°F)	0.15
NF3D	T5A	160	350	60/70		0.28
NF6D	T16A	320	350	200/215		0.57
NF8D	T18A	500	350	465/500		1.24

PERFORMANCE CURVES

► Adjustment Sensitivity at 7 bar Differential

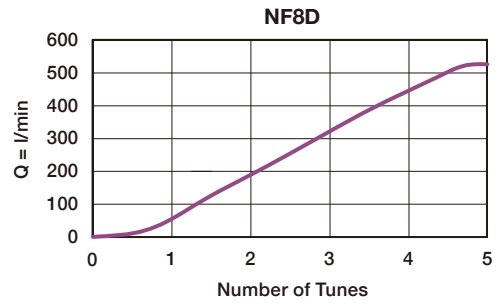
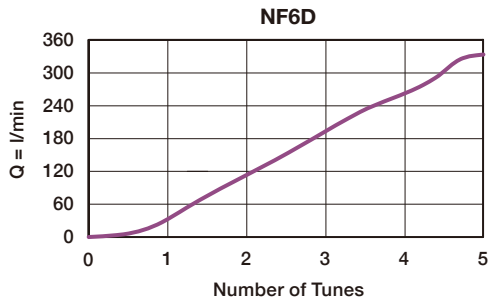
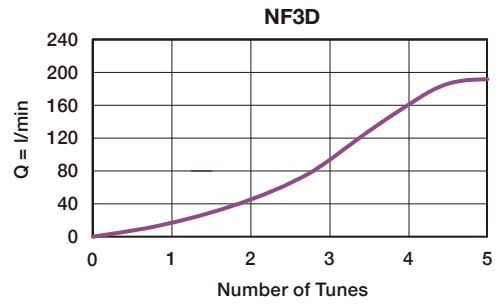
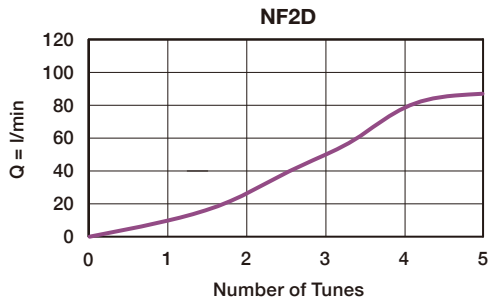

DIMENSION

(UNIT : mm)

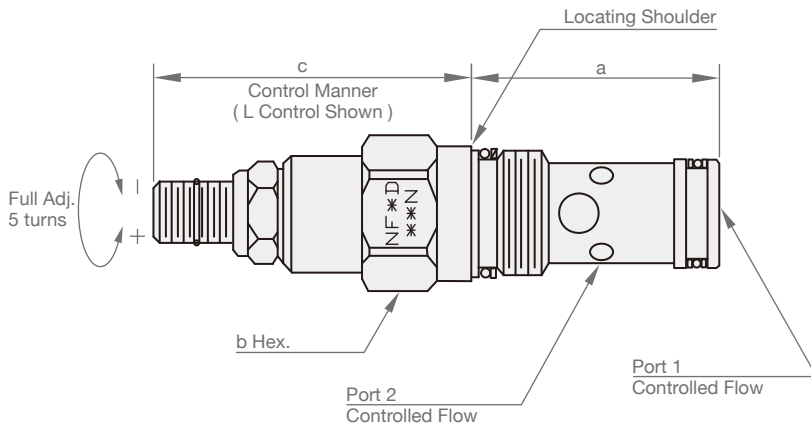

Model	a	b	c	
			L	K
NF2D	34.9	22.2	58	64
NF3D	41.1	28.6	67	73
NF6D	61.9	31.8	73	79
NF8D	79.4	41.3	84	90

NCB



SYMBOLS

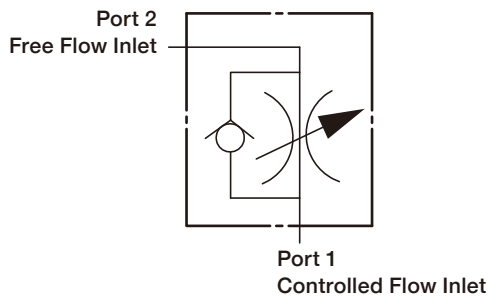

ORDER CODES

NC **2B** - **T13A** - **L** **C** **N**

① ② ③ ④ ⑤ ⑥

①	Model Name	NC	
②	Valve Size	2B, 3B, 6B, 8B	
③	Cavity & Max. Orifice	T13A	4.8mm
		T5A	6.3mm
		T16A	9.6mm
		T18A	14.2mm
④	Control Manner	L	standard screw adjustment
		K	hand knob with lock knob
⑤	Cracking Pressure	A	0.3 bar
		C	2.0 bar
		E	5.0 bar
⑥	Material of Seal	N	buna-N
		V	viton
		E	EPDM
		H	HNBR
		U	polyurethane

MODEL SPEC.

Model	Cavity	Capacity (l/min)	Max. Pressure (bar)	Installation Torque (Nm)	Operating Temperature	Weight (kg)
NC2B	T13A	25	350	40/50	-35 ~ 100°C (-31 ~ 212°F)	0.14
NC3B	T5A	50	350	60/70		0.26
NC6B	T16A	100	350	200/215		0.58
NC8B	T18A	200	350	465/500		1.23

PERFORMANCE CURVES

► Adjustment Sensitivity at 7 bar Differential

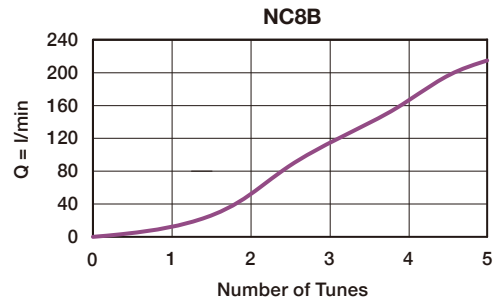
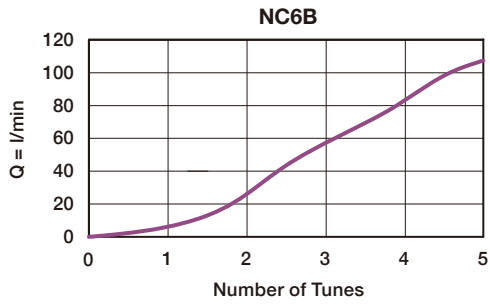
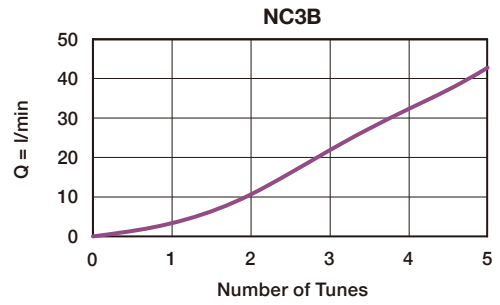
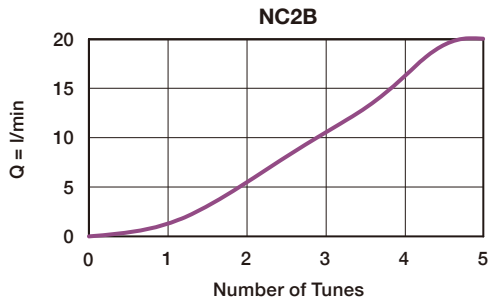

DIMENSION

(UNIT : mm)

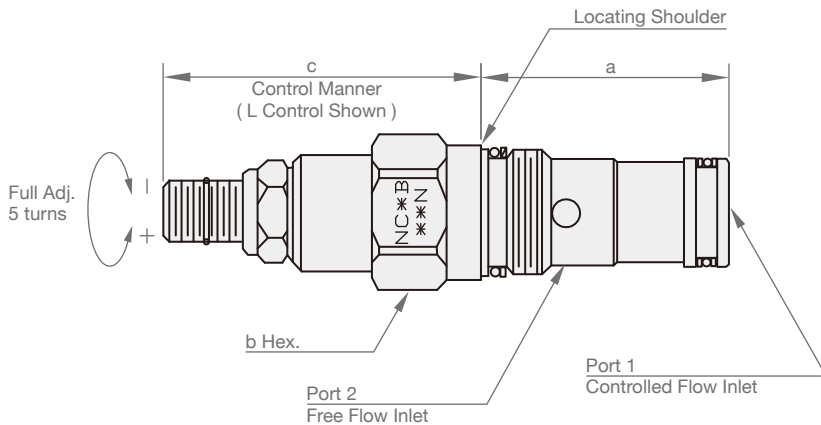

Model	a	b	c	
			L	K
NC2B	34.9	22.2	58	64
NC3B	41.1	28.6	67	73
NC6B	61.9	31.8	73	79
NC8B	79.4	41.3	84	90

FD



SYMBOLS

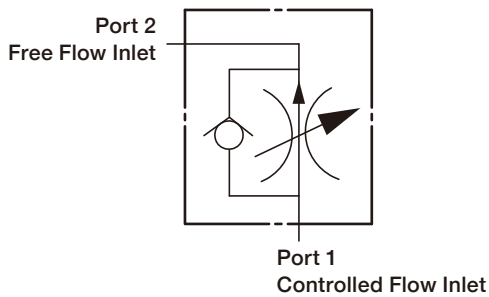

ORDER CODES

FD **2A** - **T13A** - **L** **A** **N**

1 2 3 4 5 6

1	▶ Model Name	FD
2	▶ Valve Size	2A, 3B, 6A, 8A
3	▶ Cavity	T13A, T5A, T16A, T18A
4	▶ Control Manner	L standard screw adjustment
		K hand knob with lock knob
5	▶ Adjustable Range	A 2A : 0.4 ~ 23 l/min 3B : 0.4 ~ 45 l/min 6A : 1.0 ~ 95 l/min 8A : 1.0 ~ 200 l/min
6	▶ Material of Seal	N buna-N
		V viton
		E EPDM
		H HNBR
		U polyurethane

MODEL SPEC.

Model	Cavity	Capacity (l/min)	Max. Pressure (bar)	Installation Torque (Nm)	Operating Temperature	Weight (kg)
FD2A	T13A	23	350	40/50	-35 ~ 100°C (-31 ~ 212°F)	0.14
FD3B	T5A	45	350	60/70		0.28
FD6A	T16A	95	350	200/215		0.55
FD8A	T18A	200	350	465/500		1.23

PERFORMANCE CURVES

► Typical Performance

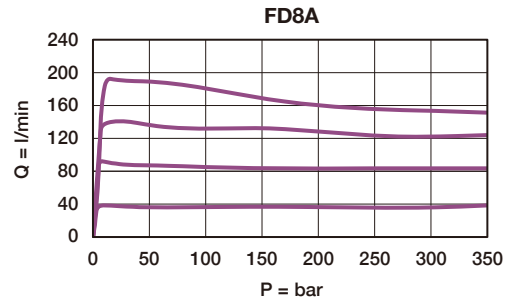
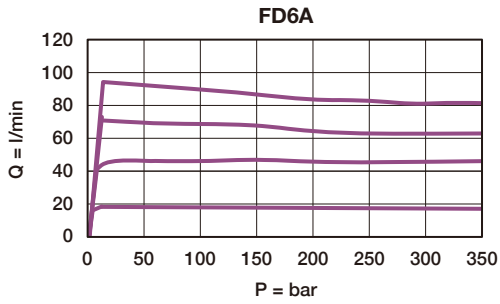
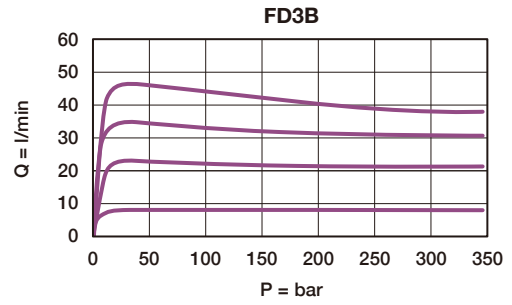
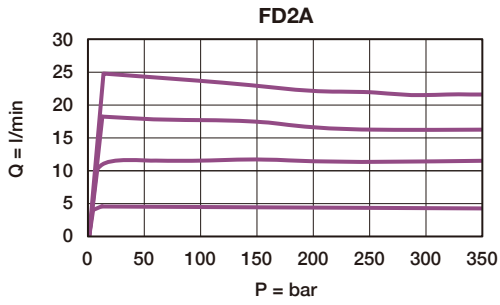

DIMENSION

(UNIT : mm)

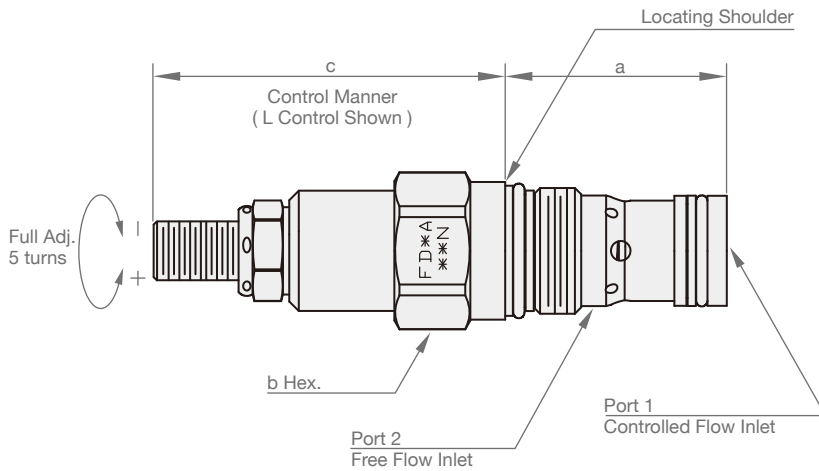

Model	a	b	c	
			L	K
FD2A	34.9	22.2	58	64
FD3B	41.1	28.6	67	73
FD6A	61.9	31.8	73	79
FD8A	79.4	41.3	84	90

LRA



SYMBOLS

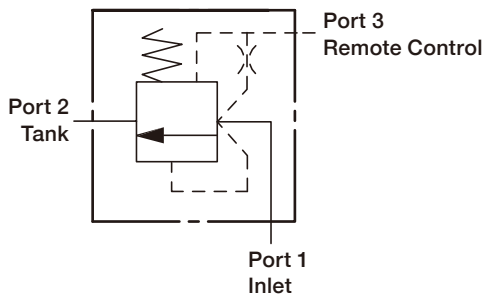

ORDER CODES

LR 2 A - T11A - X D N

1 2 3 4 5 6 7

1	▶ Model Name	LR
2	▶ Valve Size	2, 3, 6, 8
3	▶ Type	A internal pilot
4	▶ Cavity	T11A, T2A, T17A, T19A
5	▶ Control Manner	X unadjustable
		L standard screw adjustment
6	▶ Cracking Pressure	D 3.5 bar
		F 7.0 bar
		G 10.0 bar
7	▶ Material of Seal	N buna-N
		V viton
		E EPDM
		H HNBR
		U polyurethane

MODEL SPEC.

Model	Cavity	Capacity (l/min)	Max. Pressure (bar)	Installation Torque (Nm)	Operating Temperature	Weight (kg)
LR2A	T11A	60	350	40/50	-35 ~ 100°C (-31 ~ 212°F)	0.12
LR3A	T2A	120	350	60/70		0.22
LR6A	T17A	240	350	200/215		0.50
LR8A	T19A	480	350	465/500		1.15

PERFORMANCE CURVES

► Typical Pressure Drop

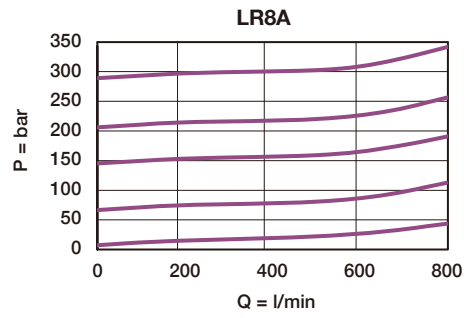
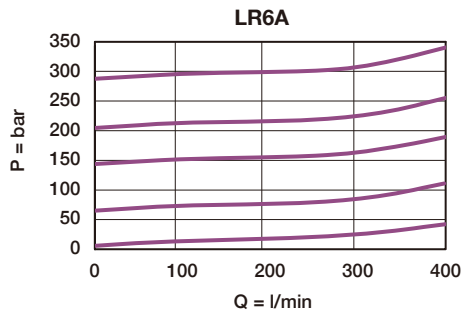
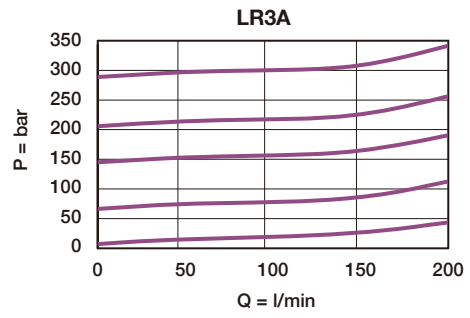
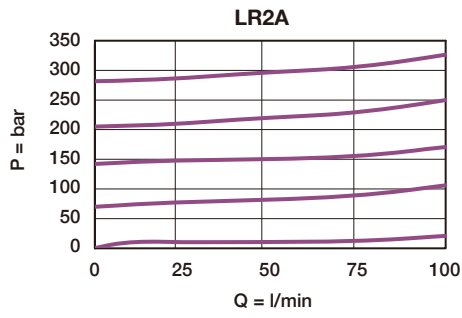

DIMENSION

(UNIT : mm)

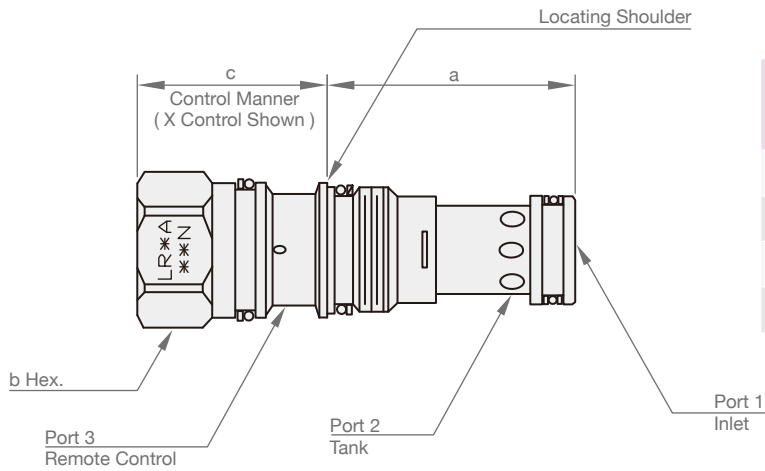

Model	a	b	c	
			X	L
LR2A	34.9	22.2	31	64
LR3A	34.9	28.6	35	72
LR6A	46.0	31.8	46	84
LR8A	63.5	41.3	59	100

LRC



SYMBOLS

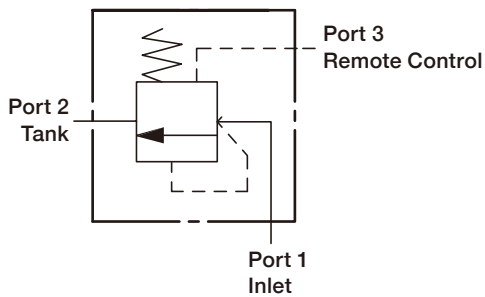

ORDER CODES

LR 2 C - T11A - X D N

1 2 3 4 5 6 7

1	▶ Model Name	LR
2	▶ Valve Size	2, 3, 6, 8
3	▶ Type	C external pilot
4	▶ Cavity	T11A, T2A, T17A, T19A
5	▶ Control Manner	X unadjustable L standard screw adjustment
6	▶ Cracking Pressure	D 3.5 bar F 7.0 bar G 10.0 bar
7	▶ Material of Seal	N buna-N V viton E EPDM H HNBR U polyurethane

MODEL SPEC.

Model	Cavity	Capacity (l/min)	Max. Pressure (bar)	Installation Torque (Nm)	Operating Temperature	Weight (kg)
LR2C	T11A	60	350	40/50	-35 ~ 100°C (-31 ~ 212°F)	0.12
LR3C	T2A	120	350	60/70		0.22
LR6C	T17A	240	350	200/215		0.50
LR8C	T19A	480	350	465/500		1.15

PERFORMANCE CURVES

► Typical Pressure Drop

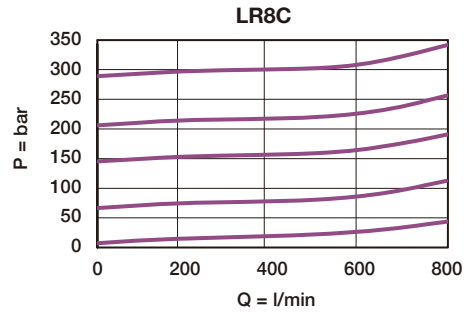
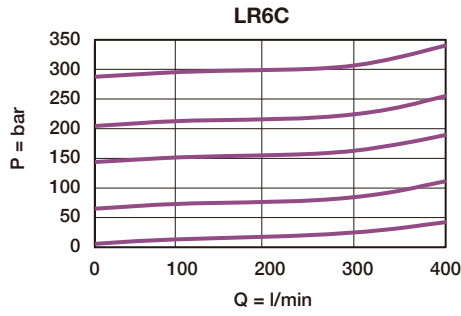
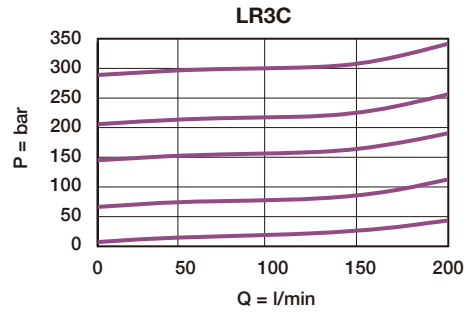
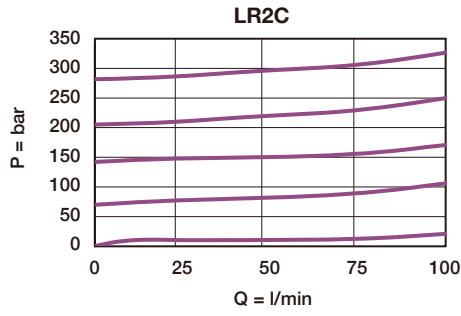

DIMENSION

(UNIT : mm)

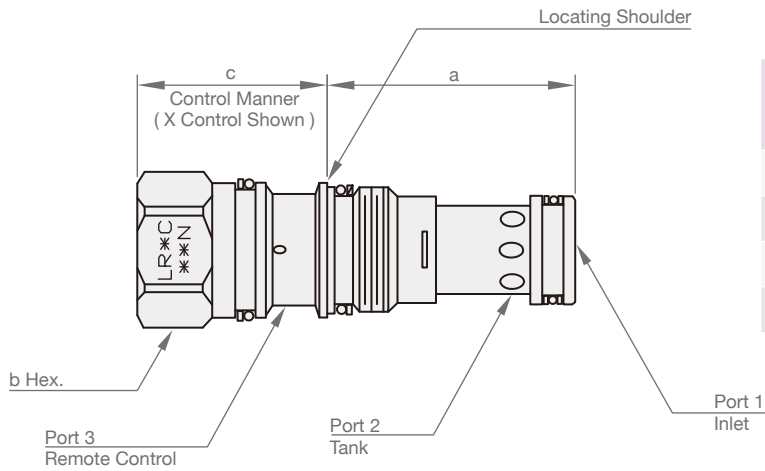

Model	a	b	c	
			X	L
LR2C	34.9	22.2	31	64
LR3C	34.9	28.6	35	72
LR6C	46.0	31.8	46	84
LR8C	63.5	41.3	59	100

CKA



SYMBOLS

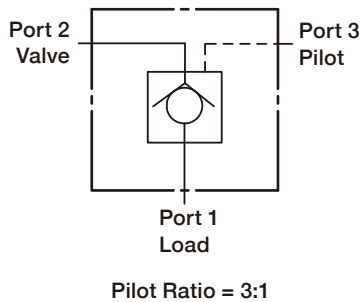

ORDER CODES

CK 2 A - T11A - X C N

1 2 3 4 5 6 7

1	Model Name	CK
2	Valve Size	2, 3, 6, 8
3	Pilot Version	A bleed through pilot
4	Cavity	T11A, T2A, T17A, T19A
5	Control Manner	X standard pilot L manual load release
6	Cracking Pressure	A 0.3 bar C 2.0 bar E 5.0 bar
7	Material of Seal	N buna-N V viton E EPDM H HNBR U polyurethane

MODEL SPEC.

Model	Cavity	Capacity (l/min)	Max. Pressure (bar)	Installation Torque (Nm)	Operating Temperature	Weight (kg)
CK2A	T11A	60	350	45/50	-35 ~ 100°C (-31 ~ 212°F)	0.13
CK3A	T2A	120	350	60/70		0.24
CK6A	T17A	240	350	200/215		0.53
CK8A	T19A	480	350	465/500		1.16

PERFORMANCE CURVES

► Typical Pressure Drop

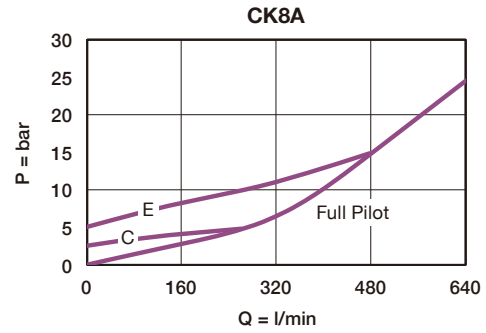
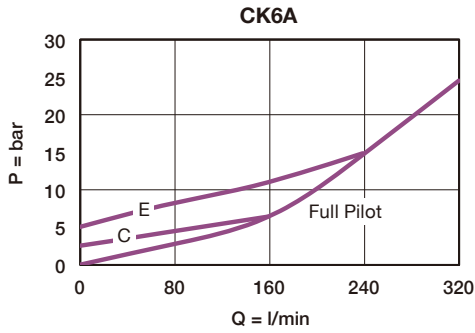
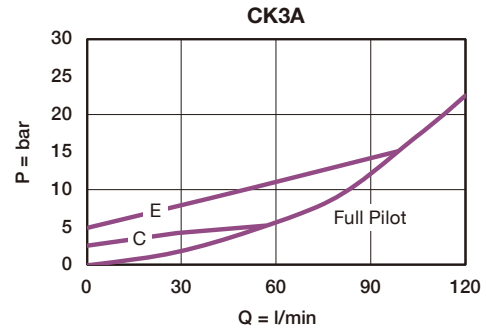
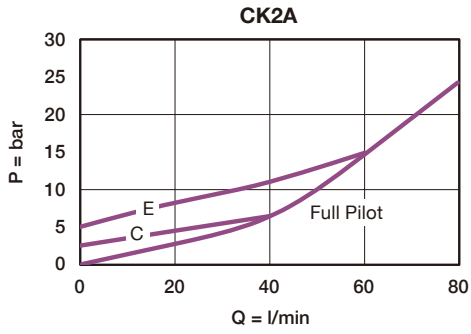

DIMENSION

(UNIT : mm)

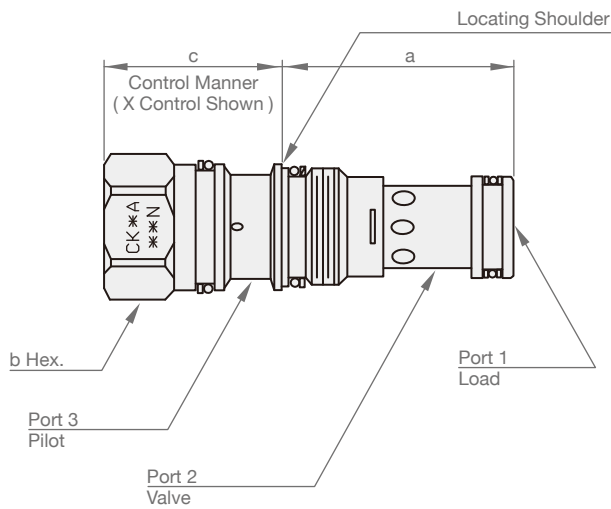

Model	a	b	c	
			X	L
CK2A	34.9	22.2	31	64
CK3A	34.9	28.6	35	72
CK6A	46.0	31.8	46	84
CK8A	63.5	41.3	59	100

CKB



SYMBOLS

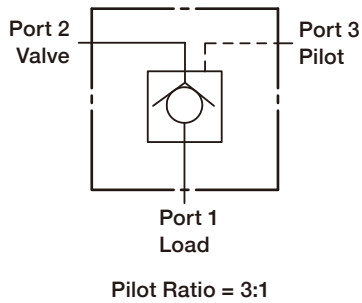

ORDER CODES

CK 2 B - T11A - X C N

1 2 3 4 5 6 7

1	▶ Model Name	CK
2	▶ Valve Size	1, 2, 3, 6, 8
3	▶ Pilot Version	B bleed through pilot
4	▶ Cavity	T163A, T11A, T2A, T17A, T19A
5	▶ Control Manner	X standard pilot L manual load release
6	▶ Cracking Pressure	A 0.3 bar C 2.0 bar E 5.0 bar
7	▶ Material of Seal	N buna-N V viton E EPDM H HNBR U polyurethane

MODEL SPEC.

Model	Cavity	Capacity (l/min)	Max. Pressure (bar)	Installation Torque (Nm)	Operating Temperature	Weight (kg)
CK1B	T163A	28.4	350	40/48	-35 ~ 100°C (-31 ~ 212°F)	0.09
CK2B	T11A	60	350	40/50		0.10
CK3B	T2A	120	350	60/70		0.24
CK6B	T17A	240	350	200/215		0.53
CK8B	T19A	480	350	465/500		1.16

PERFORMANCE CURVES

► Typical Pressure Drop

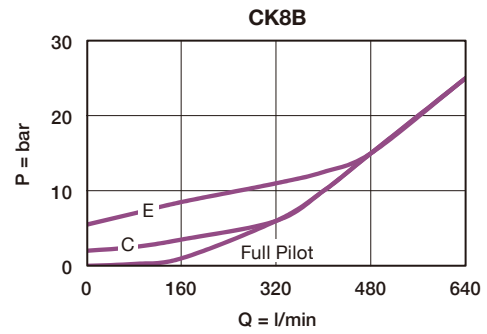
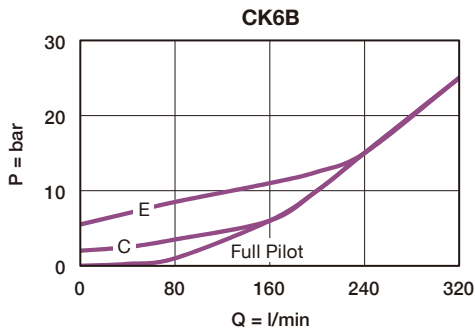
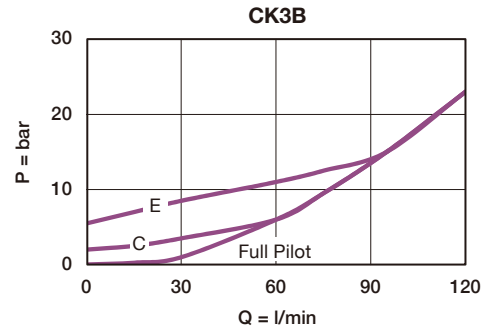
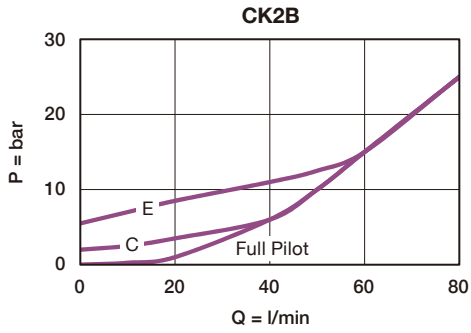
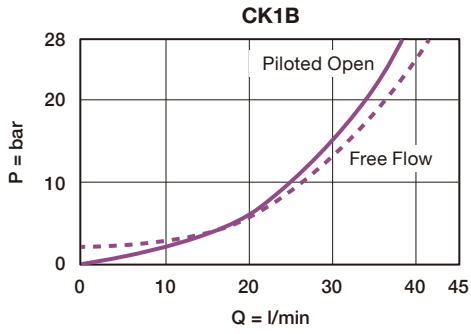

DIMENSION

(UNIT : mm)

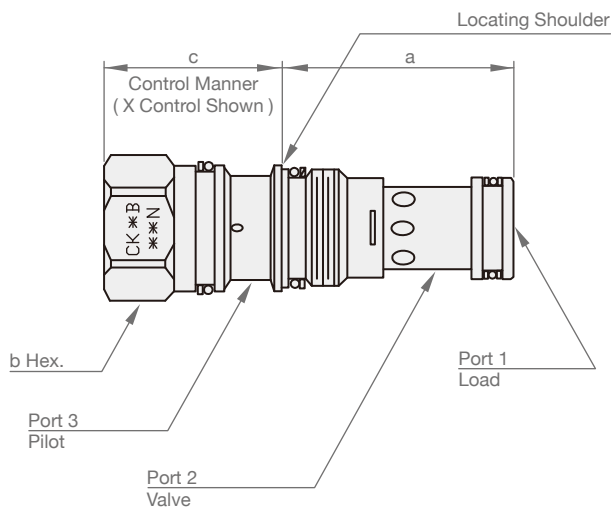

Model	a	b	c	
			X	L
CK1B	31.2	19	32	64
CK2B	34.9	22.2	31	64
CK3B	34.9	28.6	35	72
CK6B	46.0	31.8	46	84
CK8B	63.5	41.3	59	100

CKC



SYMBOLS

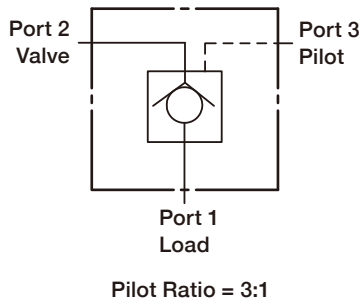

ORDER CODES

CK 2 C - T11A - X C N

1 2 3 4 5 6 7

1	▶ Model Name	CK
2	▶ Valve Size	2, 3, 6, 8
3	▶ Pilot Version	C sealed pilot & POM seat
4	▶ Cavity	T11A, T2A, T17A, T19A
5	▶ Control Manner	X standard pilot L manual load release
6	▶ Cracking Pressure	A 0.3 bar C 2.0 bar E 5.0 bar
7	▶ Material of Seal	N buna-N V viton E EPDM H HNBR U polyurethane

MODEL SPEC.

Model	Cavity	Capacity (l/min)	Max. Pressure (bar)	Installation Torque (Nm)	Operating Temperature	Weight (kg)
CK2C	T11A	60	350	45/50	-35 ~ 100°C (-31 ~ 212°F)	0.13
CK3C	T2A	120	350	60/70		0.24
CK6C	T17A	240	350	200/215		0.53
CK8C	T19A	480	350	465/500		1.16

PERFORMANCE CURVES

► Typical Pressure Drop

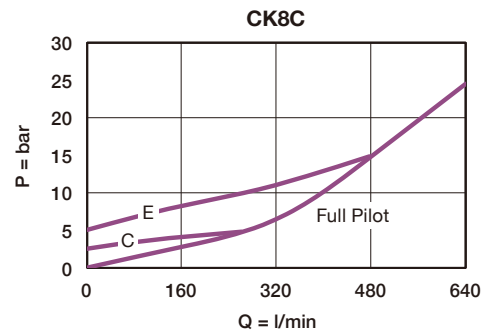
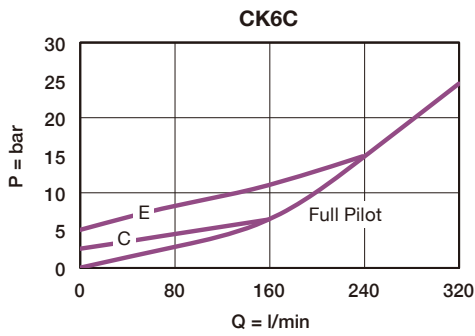
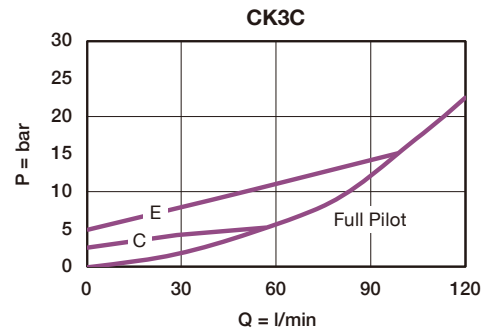
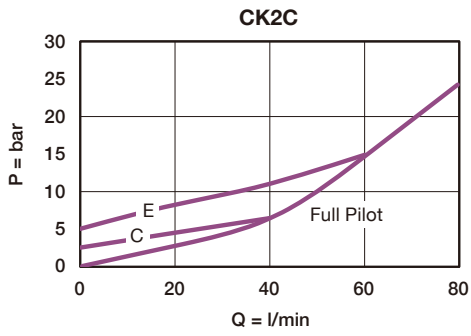

DIMENSION

(UNIT : mm)

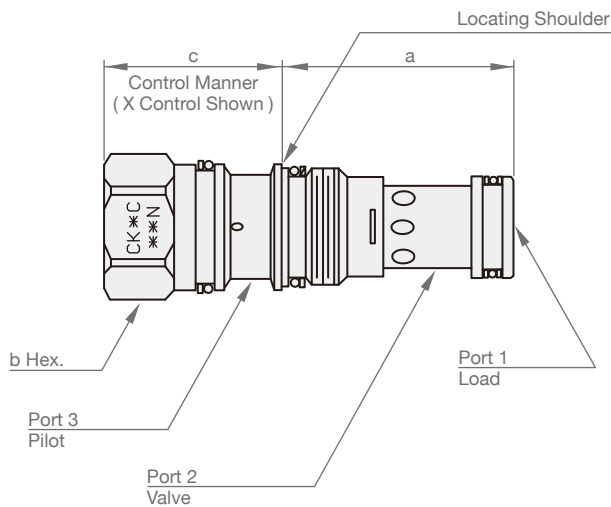

Model	a	b	c	
			X	L
CK2C	34.9	22.2	31	64
CK3C	34.9	28.6	35	72
CK6C	46.0	31.8	46	84
CK8	63.5	41.3	59	100

CKD



SYMBOLS

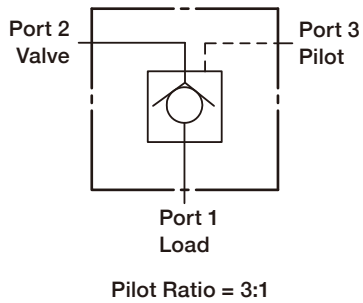

ORDER CODES

CK 2 D - T11A - X C N

1 2 3 4 5 6 7

1	Model Name	CK
2	Valve Size	2, 3, 6, 8
3	Pilot Version	D sealed pilot
4	Cavity	T11A, T2A, T17A, T19A
5	Control Manner	X standard pilot L manual load release
6	Cracking Pressure	A 0.3 bar C 2.0 bar E 5.0 bar
7	Material of Seal	N buna-N V viton E EPDM H HNBR U polyurethane

MODEL SPEC.

Model	Cavity	Capacity (l/min)	Max. Pressure (bar)	Installation Torque (Nm)	Operating Temperature	Weight (kg)
CK2D	T11A	60	350	40/50	-35 ~ 100°C (-31 ~ 212°F)	0.13
CK3D	T2A	120	350	60/70		0.24
CK6D	T17A	240	350	200/215		0.53
CK8D	T19A	480	350	465/500		1.16

PERFORMANCE CURVES

► Typical Pressure Drop

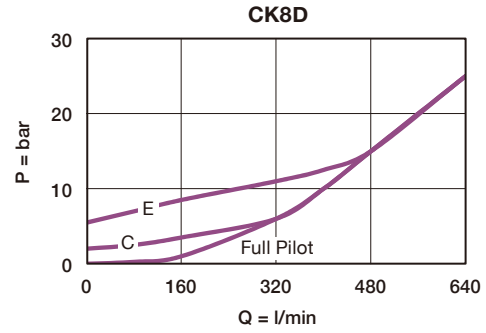
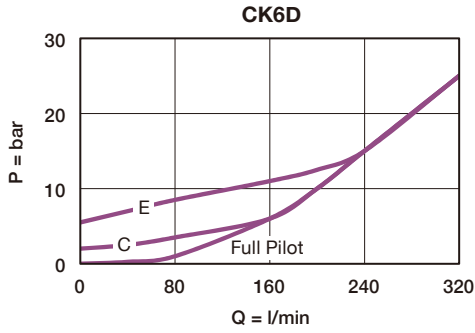
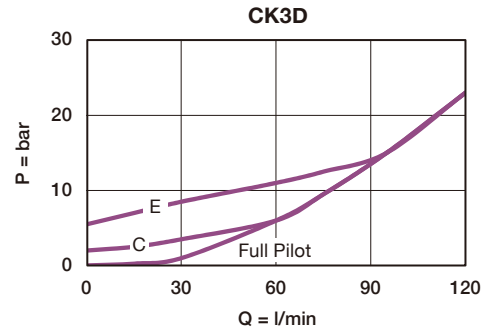
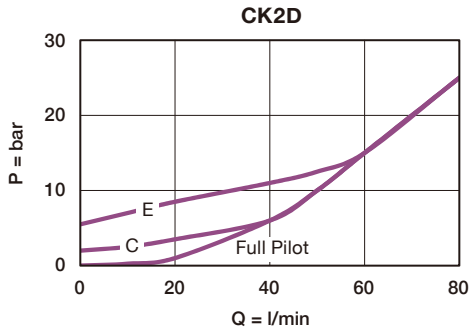

DIMENSION

(UNIT : mm)

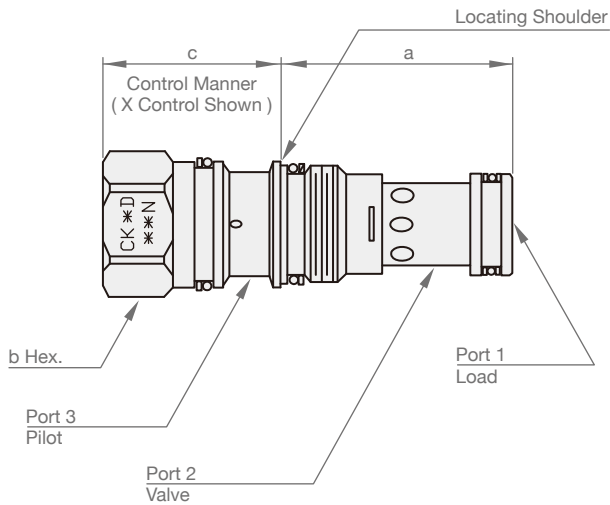

Model	a	b	c	
			X	L
CK2D	34.9	22.2	31	64
CK3D	34.9	28.6	35	72
CK6D	46.0	31.8	46	84
CK8D	63.5	41.3	59	100

CKF



SYMBOLS

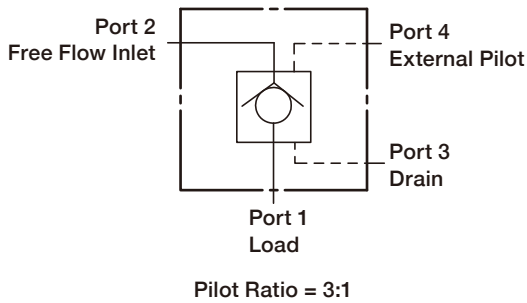

ORDER CODES

CK **2** **F** - **T11A** - **V** **C** **N**

1 2 3 4 5 6 7

1	▶ Model Name	CK
2	▶ Valve Size	2, 3, 6, 8
3	▶ Pilot Version	F external pilot
4	▶ Cavity	T11A, T2A, T17A, T19A
5	▶ Control Manner	V external pilot port
6	▶ Cracking Pressure	A 0.3 bar
		C 2.0 bar
		E 5.0 bar
7	▶ Material of Seal	N buna-N
		V viton
		E EPDM
		H HNBR
		U polyurethane

MODEL SPEC.

Model	Cavity	Capacity (l/min)	Max. Pressure (bar)	Installation Torque (Nm)	Operating Temperature	Weight (kg)
CK2F	T11A	60	350	40/50	-35 ~ 100°C (-31 ~ 212°F)	0.13
CK3F	T2A	120	350	60/70		0.24
CK6F	T17A	240	350	200/215		0.53
CK8F	T19A	480	350	465/500		1.16

PERFORMANCE CURVES

► Typical Pressure Drop

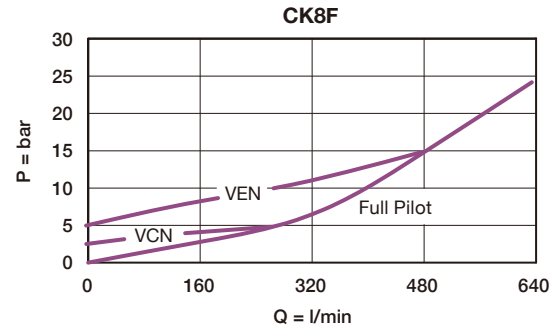
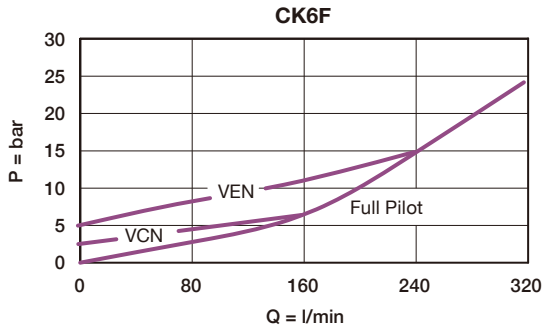
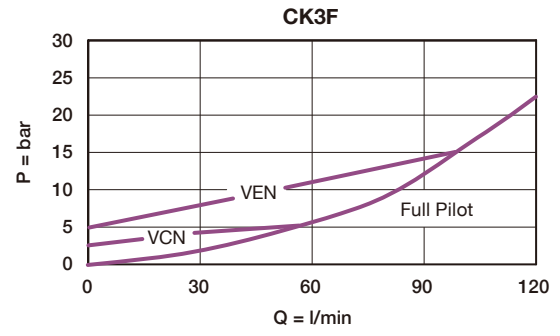
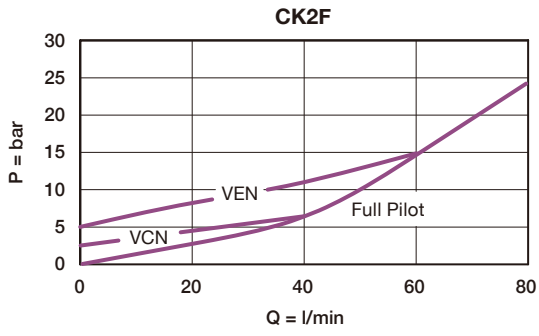

DIMENSION

(UNIT : mm)

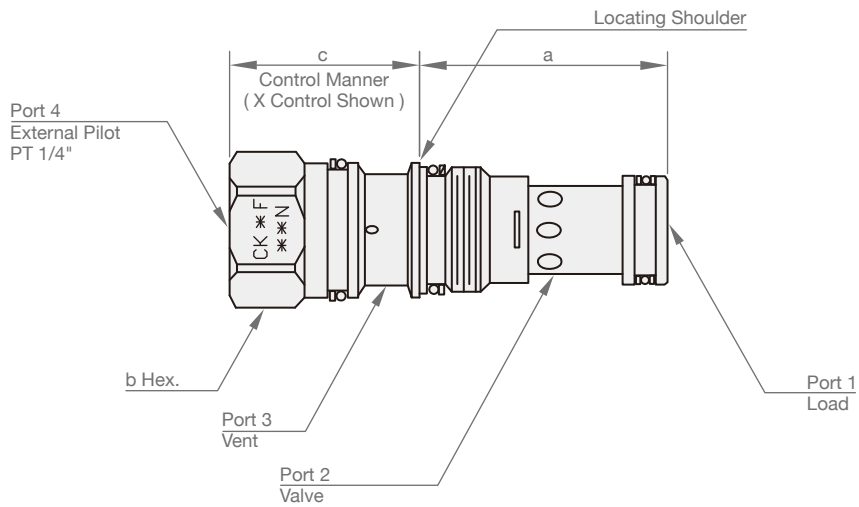

Model	a	b	c	
			X	L
CK2B	34.9	22.2	31	64
CK3B	34.9	28.6	35	72
CK6B	46.0	31.8	46	84
CK8B	63.5	41.3	59	100

CVV



SYMBOLS

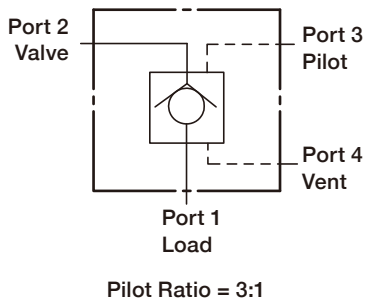

ORDER CODES

CV **2V** - **T21A** - **X** **C** **N**

1 2 3 4 5 6

1	▶ Model Name	CV	
2	▶ Valve Size	2V, 3V, 6V, 8V	
3	▶ Cavity	T21A, T22A, T23A, T24A	
4	▶ Control Manner	X	standard pilot
		L	manual load release
5	▶ Cracking Pressure	A	0.3 bar
		C	2.0 bar
		E	5.0 bar
6	▶ Material of Seal	N	buna-N
		V	viton
		E	EPDM
		H	HNBR
		U	polyurethane

MODEL SPEC.

Model	Cavity	Capacity (l/min)	Max. Pressure (bar)	Installation Torque (Nm)	Operating Temperature	Weight (kg)
CV2V	T21A	60	350	45/50	-35 ~ 100°C (-31 ~ 212°F)	0.18
CV3V	T22A	120	350	60/70		0.30
CV6V	T23A	240	350	200/215		0.68
CV8V	T24A	480	350	465/500		1.49

PERFORMANCE CURVES

► Unloaded Pressure Drop

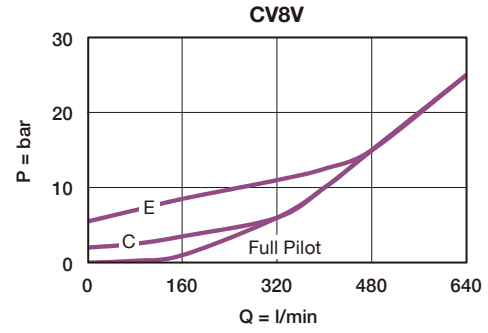
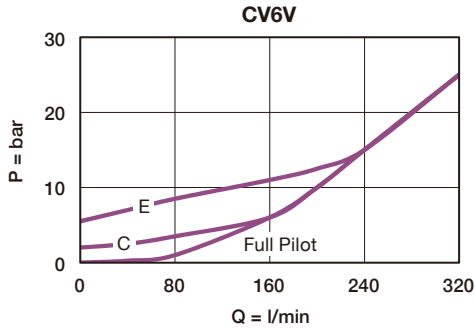
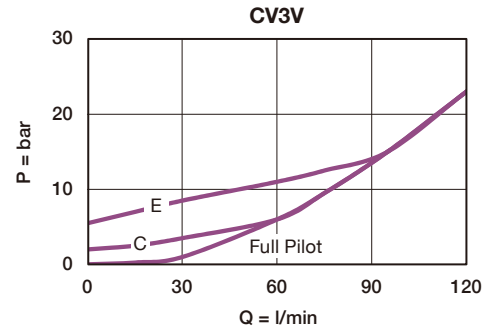
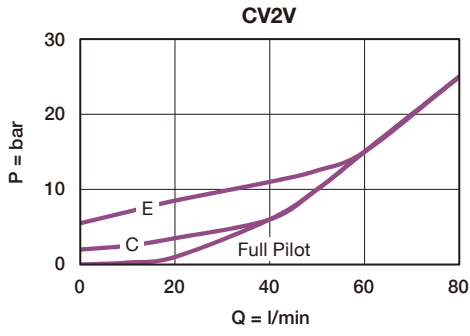

DIMENSION

(UNIT : mm)

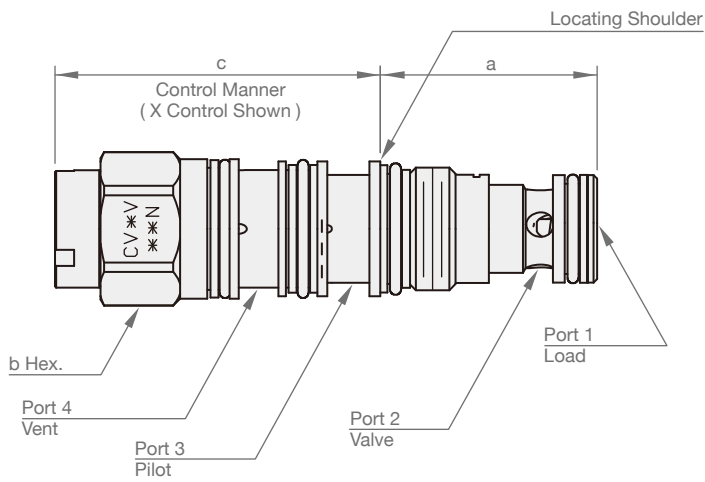

Model	a	b	c	
			X	L
CV2V	35.1	22.2	53.3	59.4
CV3V	35.1	28.6	59.4	65.0
CV6V	46.0	31.8	71.4	77.0
CV8V	63.5	41.3	88.9	95.8

CSD, CSB



SYMBOLS

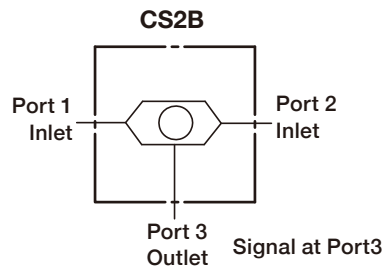
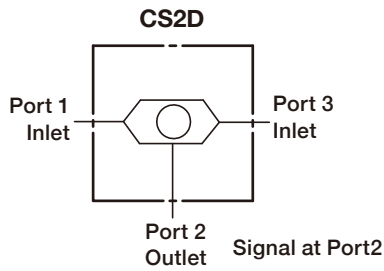

ORDER CODES

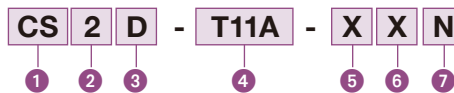

1	▶ Model Name	CS	
2	▶ Valve Size	2	
3	▶ Operation	D	T11A, signal at port 2
		B	T11A, signal at port 3
4	▶ Cavity	T11A	
5	▶ Control Manner	X	unadjustable
6	▶ Adjustment Range	X	unadjustable
7	▶ Material of Seal	N	buna-N
		V	viton
		E	EPDM
		H	HNBR
		U	polyurethane

MODEL SPEC.

Model	Cavity	Capacity (l/min)	Max. Pressure (bar)	Installation Torque (Nm)	Operating Temperature	Weight (kg)
CS2D	T11A	10	350	40/50	-35 ~ 100°C (-31 ~ 212°F)	0.12
CS2B	T11A	10	350	40/50		0.12

PERFORMANCE CURVES

► Typical Pressure Drop

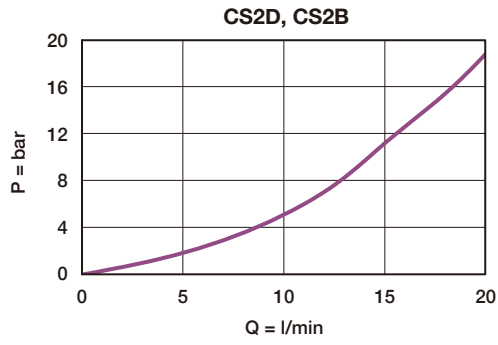

DIMENSION

(UNIT : mm)

► CS2D

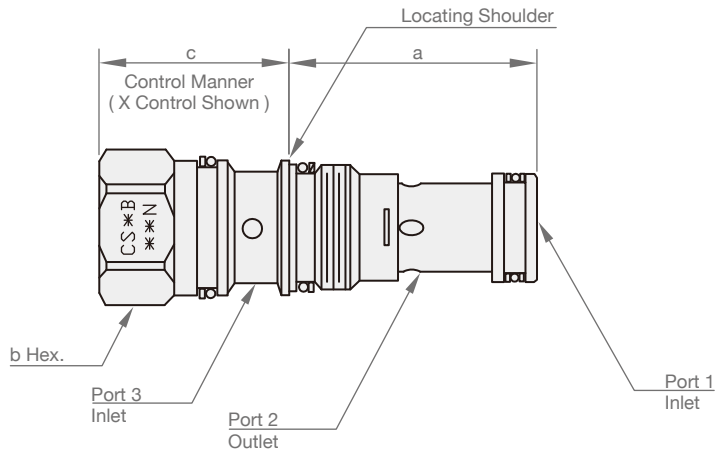

Model	a	b	c
			X
CS2D	34.9	22.2	31
CS2B	34.9	22.2	31

► CS2B

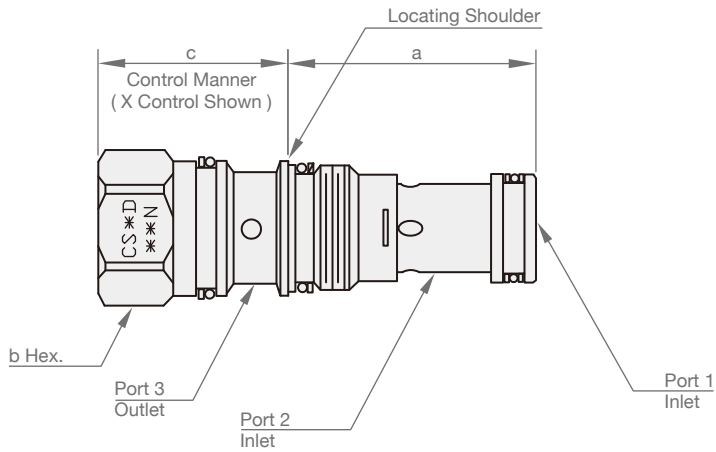

CSA, CSC



SYMBOLS

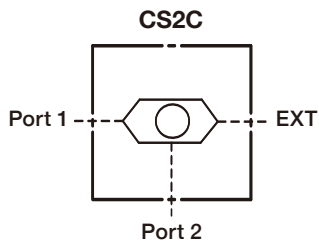
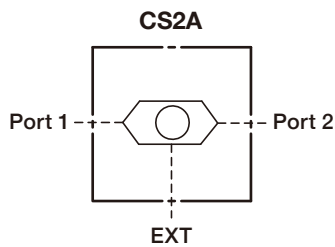

ORDER CODES

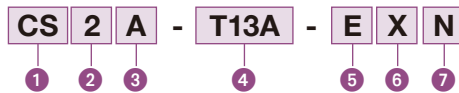

1	Model Name	CS	
2	Valve Size	2	
3	Operation	A	signal external
		C	signal at port 2
4	Cavity	T13A	
5	Control Manner	E	external 4-SAE port
6	Adjustment Range	X	unadjustable
7	Material of Seal	N	buna-N
		V	viton
		E	EPDM
		H	HNBR
		U	polyurethane

MODEL SPEC.

Model	Cavity	Capacity (l/min)	Max. Pressure (bar)	Installation Torque (Nm)	Operating Temperature	Weight (kg)
CS2A	T13A	10	350	45/50	-35 ~ 100°C	0.1
CS2C	T13A	10	350	45/50	(-31 ~ 212°F)	0.1

PERFORMANCE CURVES

► Typical Pressure Drop

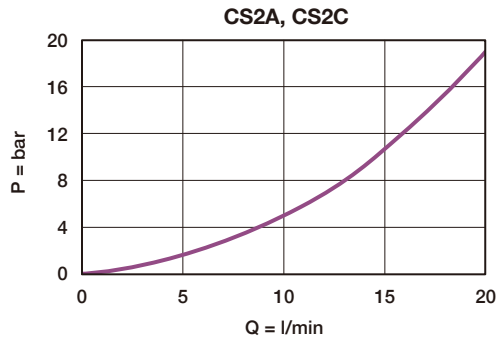

DIMENSION

(UNIT : mm)

► CS2A, CS2C

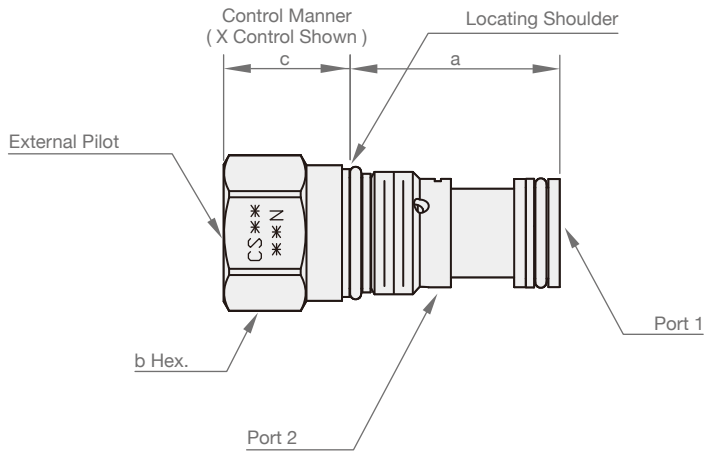

Model	a	b	c
			X
CS2A	34.9	22.2	19
CS2C	34.9	22.2	19

CXA



SYMBOLS

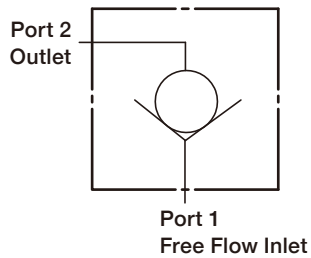

ORDER CODES

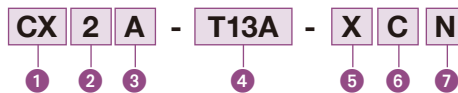

1	▶ Model Name	CX
2	▶ Valve Size	2, 3, 6, 8
3	▶ Operation	A free flow port1 to port2
4	▶ Cavity	T13A, T5A, T16A, T18A
5	▶ Control Manner	X unadjustable
6	▶ Cracking Pressure	A 0.3 bar
		B 1.0 bar
		C 2.0 bar
		D 3.5 bar
		E 5.0 bar
7	▶ Material of Seal	N buna-N
		V viton
		E EPDM
		H HNBR
		U polyurethane

MODEL SPEC.

Model	Cavity	Capacity (l/min)	Max. Pressure (bar)	Installation Torque (Nm)	Operating Temperature	Weight (kg)
CX2A	T13A	80	350	40/50	-35 ~ 100°C (-31 ~ 212°F)	0.12
CX3A	T5A	160	350	60/70		0.18
CX6A	T16A	320	350	200/215		0.42
CX8A	T18A	640	350	465/500		0.93

PERFORMANCE CURVES

► Typical Pressure Drop

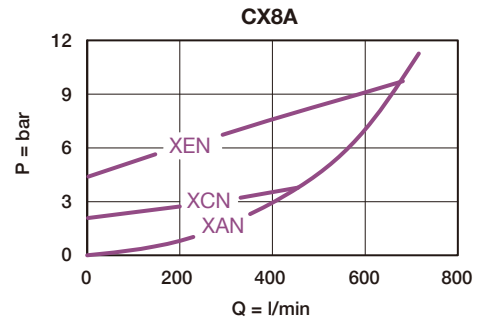
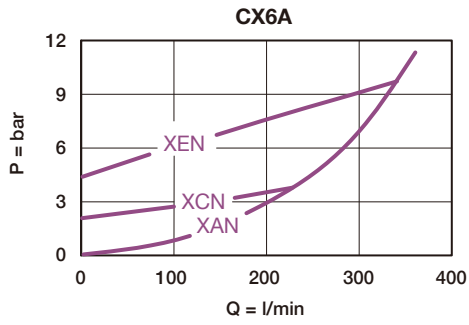
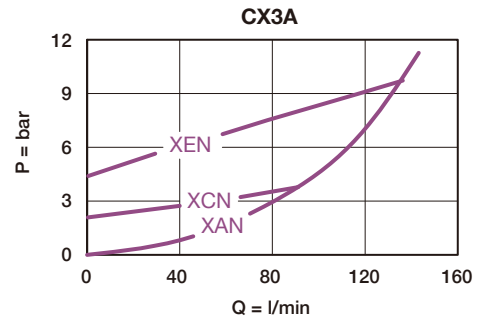
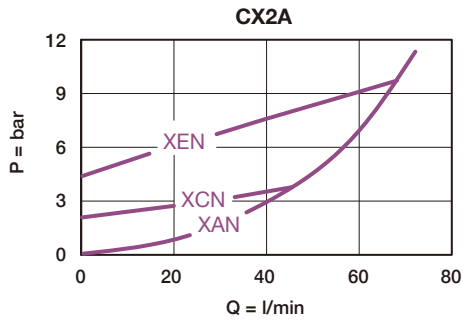

DIMENSION

(UNIT : mm)

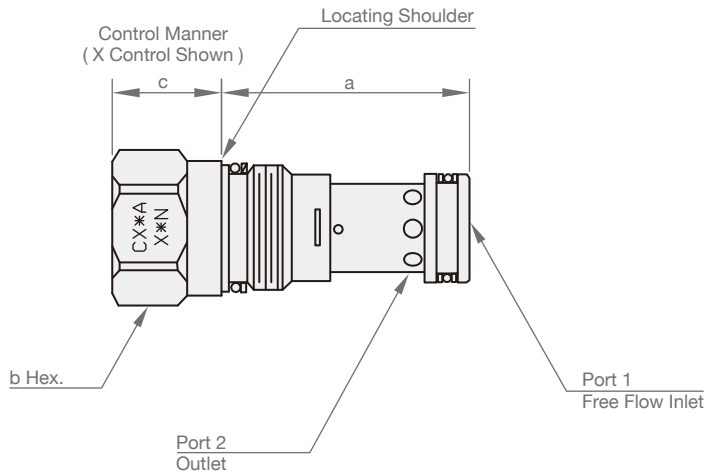

Model	a	b	c
			X
CX2A	34.9	22.2	19
CX3A	41.1	28.6	18
CX6A	61.9	31.8	25
CX8A	79.4	41.3	31

CXB



SYMBOLS

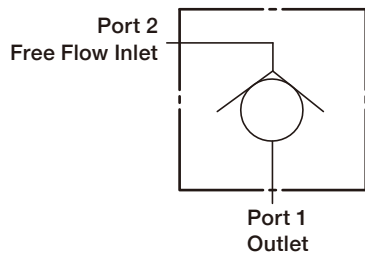

ORDER CODES

CX 2 B - T13A - X C N

1 2 3 4 5 6 7

1	Model Name	CXB
2	Valve Size	2, 3, 6, 8
3	Operation	B free flow por2 to port1, with POM seat
4	Cavity	T13A, T5A, T16A, T18A
5	Control Manner	X unadjustable
6	Cracking Pressure	A 0.3 bar
		B 1.0 bar
		C 2.0 bar
		D 3.5 bar
		E 5.0 bar
7	Material of Seal	N buna-N
		V viton
		E EPDM
		H HNBR
		U polyurethane

MODEL SPEC.

Model	Cavity	Capacity (l/min)	Max. Pressure (bar)	Installation Torque (Nm)	Operating Temperature	Weight (kg)
CX2B	T13A	60	350	45/50	-35 ~ 100°C (-31 ~ 212°F)	0.12
CX3B	T5A	120	350	60/70		0.18
CX6B	T16A	240	350	200/215		0.42
CX8B	T18A	480	350	465/500		0.93

PERFORMANCE CURVES

► Typical Pressure Drop

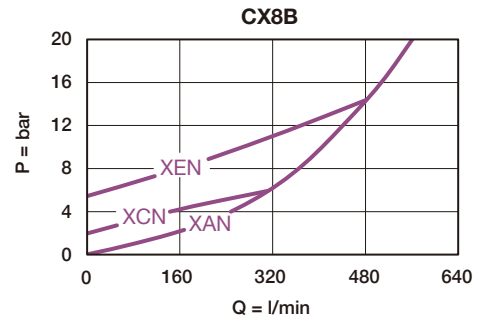
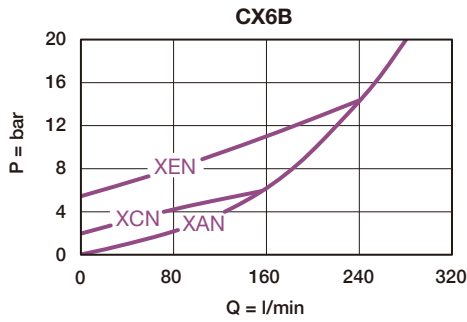
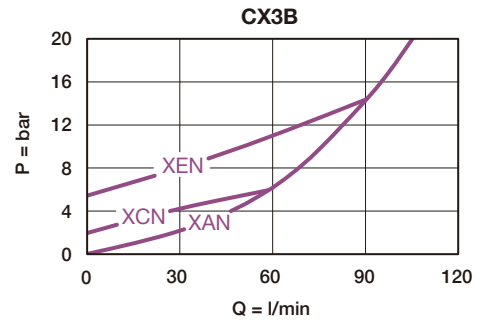
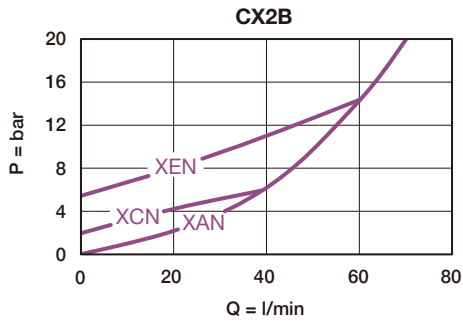

DIMENSION

(UNIT : mm)

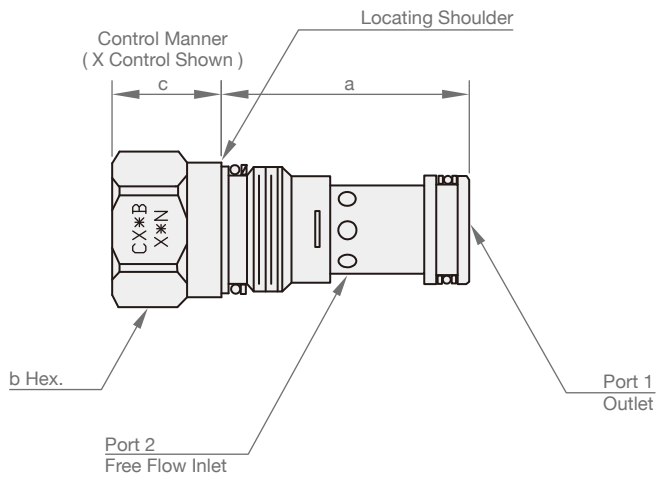

Model	a	b	c
			X
CX2B	34.9	22.2	19
CX3B	41.1	28.6	18
CX6B	61.9	31.8	25
CX8B	79.4	41.3	31

CXD



SYMBOLS

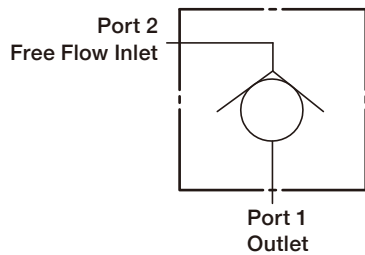

ORDER CODES

CX **2** **D** - **T13A** - **X** **C** **N**

1 2 3 4 5 6 7

1	▶ Model Name	CX
2	▶ Valve Size	2, 3, 6, 8
3	▶ Operation	D free flow por2 to port1
4	▶ Cavity	T13A, T5A, T16A, T18A
5	▶ Control Manner	X unadjustable
6	▶ Cracking Pressure	A 0.3 bar
		B 1.0 bar
		C 2.0 bar
		D 3.5 bar
		E 5.0 bar
7	▶ Material of Seal	N buna-N
		V viton
		E EPDM
		H HNBR
		U polyurethane

MODEL SPEC.

Model	Cavity	Capacity (l/min)	Max. Pressure (bar)	Installation Torque (Nm)	Operating Temperature	Weight (kg)
CX2D	T13A	60	350	40/50	-35 ~ 100°C (-31 ~ 212°F)	0.12
CX3D	T5A	120	350	60/70		0.18
CX6D	T16A	240	350	200/215		0.42
CX8D	T18A	480	350	465/500		0.93

PERFORMANCE CURVES

► Typical Pressure Drop

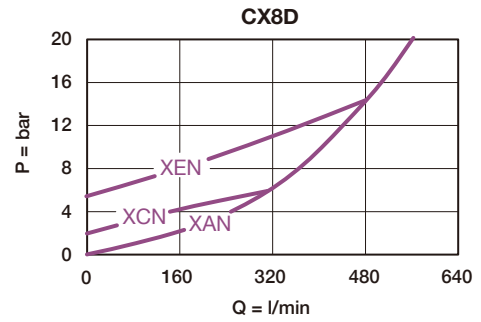
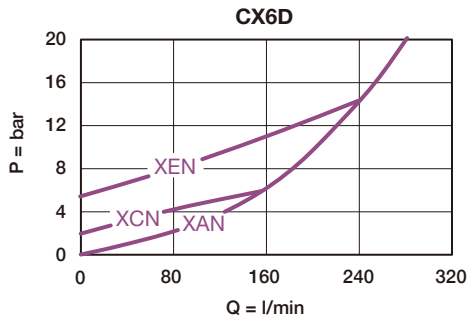
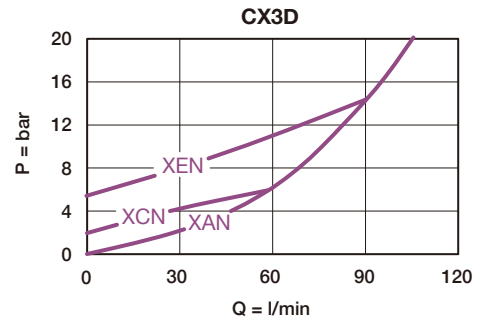
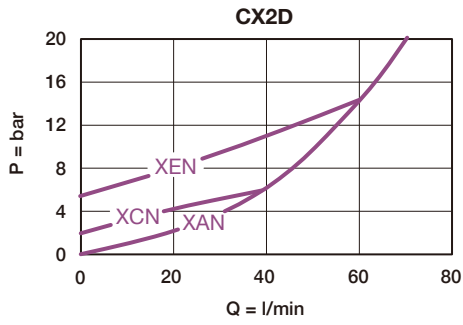

DIMENSION

(UNIT : mm)

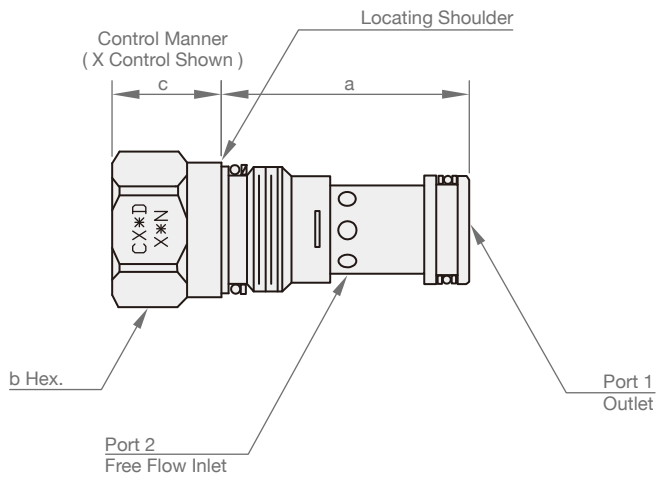

Model	a	b	c
			X
CX2D	34.9	22.2	19
CX3D	41.1	28.6	18
CX6D	61.9	31.8	25
CX8D	79.4	41.3	31

CAA



SYMBOLS

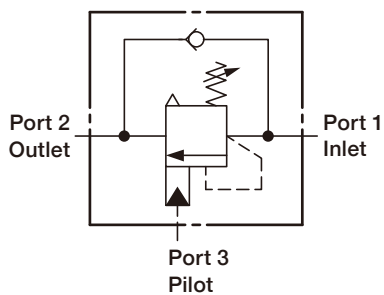

ORDER CODES

CA 2 A - T11A - L I N

1 2 3 4 5 6 7

1	▶ Model Name	CA
2	▶ Valve Size	2, 3, 6, 8
3	▶ Pilot Pressure	A 3:1
4	▶ Cavity	T11A, T2A, T17A, T19A
5	▶ Control Manner	L standard screw adjustment
6	▶ Adjustable Range	H 70 ~ 280 bar, 210 bar initially setting
		I 25 ~ 105 bar, 70 bar initially setting
7	▶ Material of Seal	N buna-N
		V viton
		E EPDM
		H HNBR
		U polyurethane

MODEL SPEC.

Model	Cavity	Capacity (l/min)	Max. Pressure (bar)	Installation Torque (Nm)	Operating Temperature	Weight (kg)
CA2A	T11A	60	350	45/50	-35 ~ 100°C (-31 ~ 212°F)	0.20
CA3A	T2A	120	350	60/70		0.38
CA6A	T17A	240	350	200/215		0.74
CA8A	T19A	480	350	465/500		1.62

PERFORMANCE CURVES

Free Flow & Piloted Open Pressure Drop

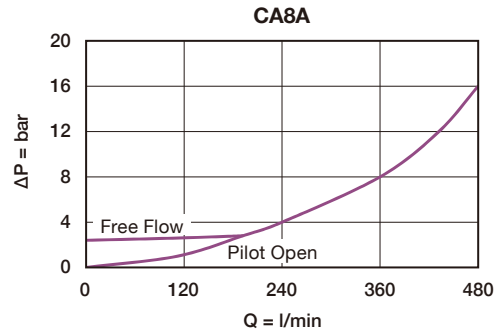
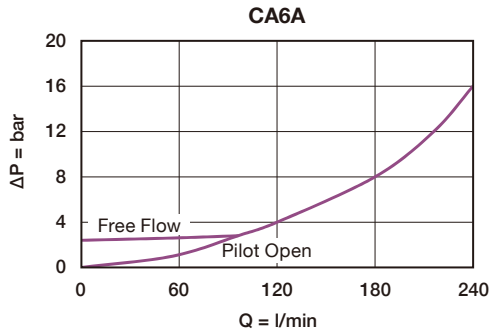
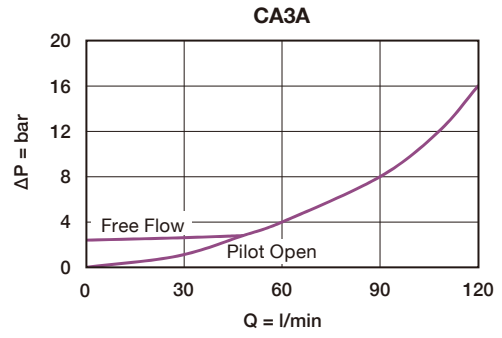
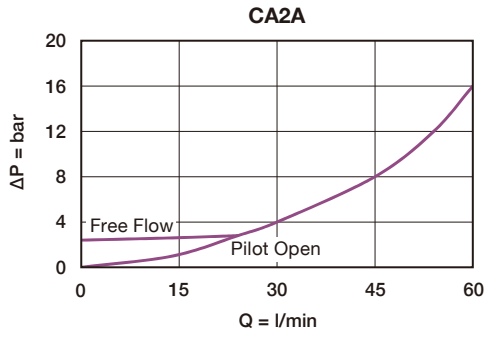

DIMENSION

(UNIT : mm)

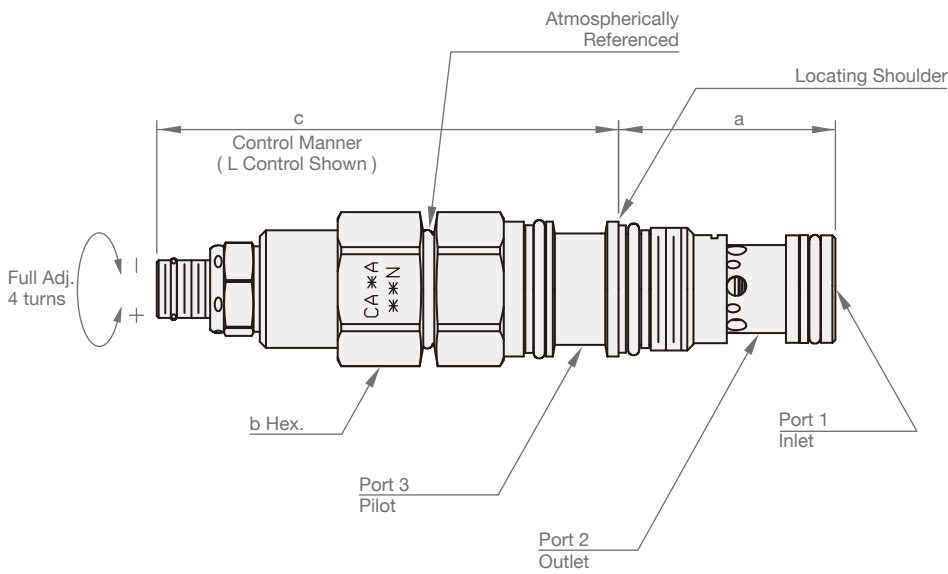

Model	a	b	c
			L
CA2A	35.1	22.2	73.4
CA3A	35.1	28.6	83.6
CA6A	46.0	31.8	95.0
CA8A	63.5	41.3	116.3

CAG



SYMBOLS

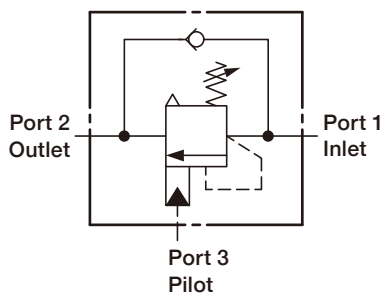

ORDER CODES

CA 2 G - T11A - L G N

1 2 3 4 5 6 7

1	▶ Model Name	CA
2	▶ Valve Size	2, 3, 6, 8
3	▶ Pilot Pressure	G 5:1
4	▶ Cavity	T11A, T2A, T17A, T19A
5	▶ Control Manner	L standard screw adjustment
6	▶ Adjustable Range	G 140 ~ 420 bar, 280 bar initially setting
		F 70 ~ 175 bar, 140 bar initially setting
7	▶ Material of Seal	N buna-N
		V viton
		E EPDM
		H HNBR
		U polyurethane

MODEL SPEC.

Model	Cavity	Capacity (l/min)	Max. Pressure (bar)	Installation Torque (Nm)	Operating Temperature	Weight (kg)
CA2G	T11A	60	350	45/50	-35 ~ 100°C (-31 ~ 212°F)	0.20
CA3G	T2A	120	350	60/70		0.38
CA6G	T17A	240	350	200/215		0.74
CA8G	T19A	480	350	465/500		1.62

PERFORMANCE CURVES

► Free Flow & Piloted Open Pressure Drop

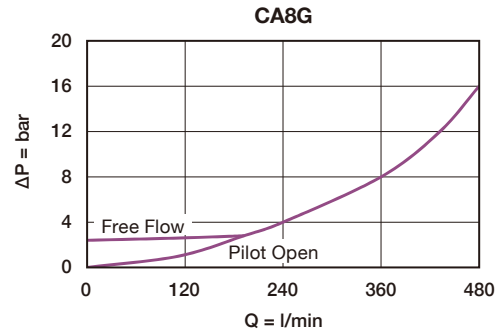
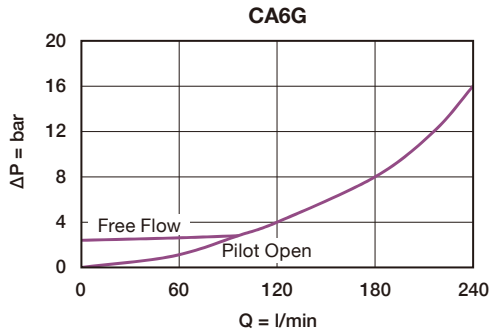
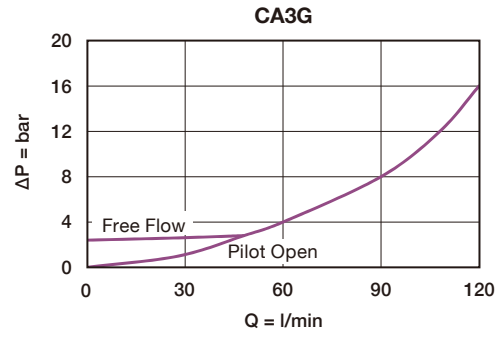
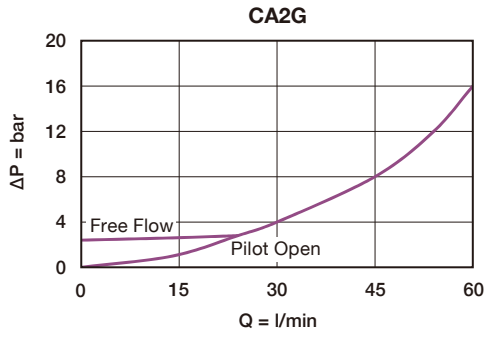

DIMENSION

(UNIT : mm)

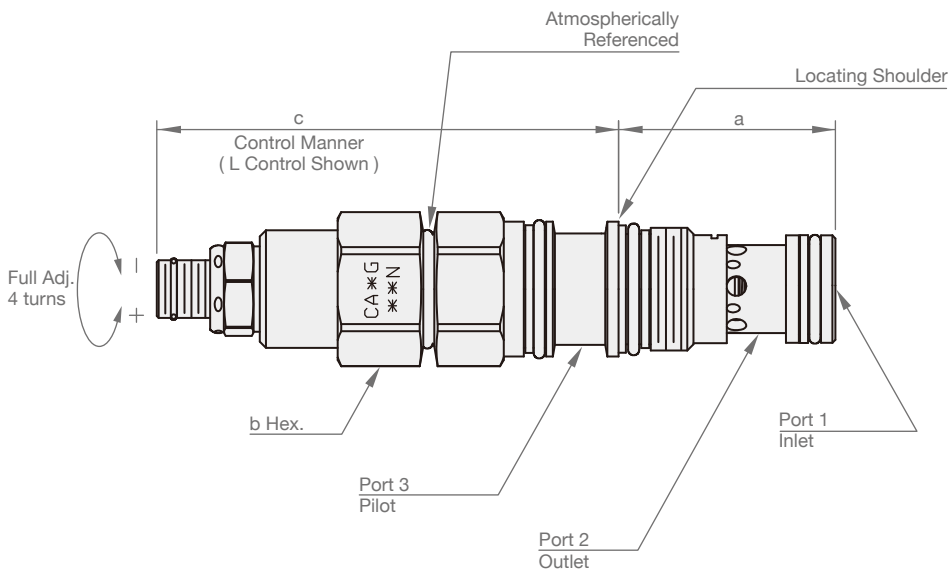

Model	a	b	c
			L
CA2G	35.1	22.2	73.4
CA3G	35.1	28.6	83.6
CA6G	46.0	31.8	95.0
CA8G	63.5	41.3	116.3

CBA



SYMBOLS

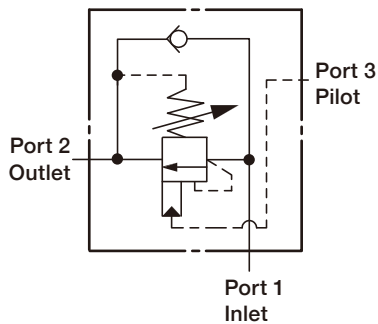

ORDER CODES

CB 2 A - T11A - L I N

1 2 3 4 5 6 7

1	▶ Model Name	CB
2	▶ Valve Size	2, 3, 6, 8
3	▶ Pilot Ratio	A 3:1
4	▶ Cavity	T11A, T2A, T17A, T19A
5	▶ Control Manner	L standard screw adjustment
6	▶ Adjustable Range	H 70 ~ 280 bar, w/1.7 bar check, 210 bar initially setting
		I 25 ~ 105 bar, w/1.7 bar check, 70 bar initially setting
		A 70 ~ 280 bar, w/0.3 bar check, 210 bar initially setting
		B 25 ~ 105 bar, w/0.3 bar check, 70 bar initially setting
7	▶ Material of Seal	N buna-N
		V viton
		E EPDM
		H HNBR
		U polyurethane

MODEL SPEC.

Model	Cavity	Capacity (l/min)	Max. Pressure (bar)	Installation Torque (Nm)	Operating Temperature	Weight (kg)
CB2A	T11A	60	350	40/50	-35 ~ 100°C (-31 ~ 212°F)	0.17
CB3A	T2A	120	350	60/70		0.30
CB6A	T17A	240	350	200/215		0.64
CB8A	T19A	480	350	465/500		1.47

PERFORMANCE CURVES

Free Flow & Piloted Open Pressure Drop

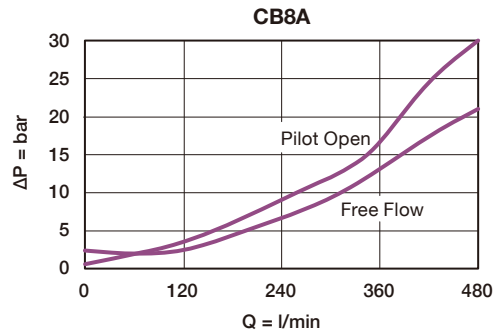
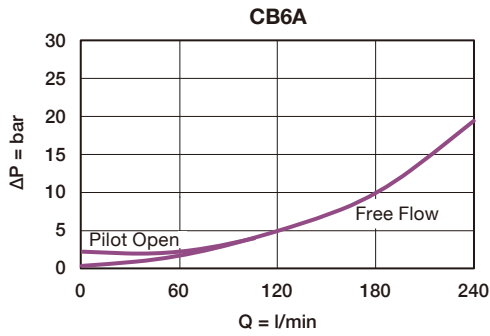
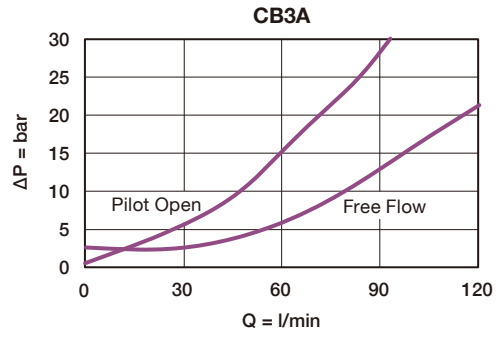
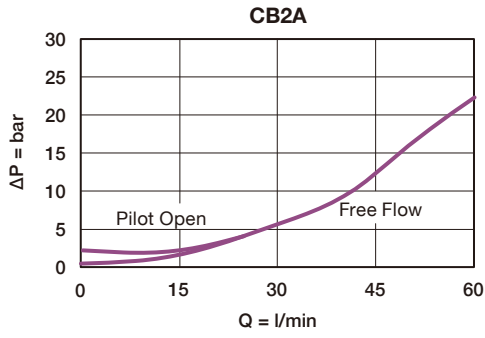

DIMENSION

(UNIT : mm)

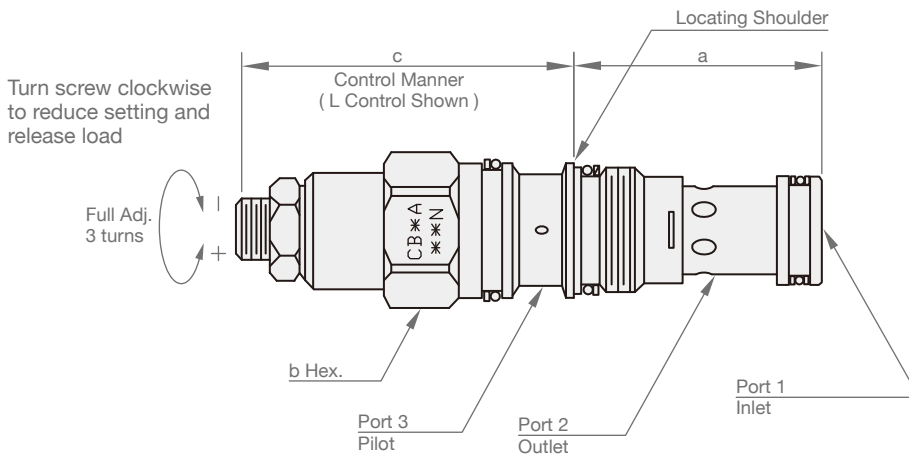

Model	a	b	c
			L
CB2A	34.9	22.2	50
CB3A	34.9	28.6	61
CB6A	46.0	31.8	70
CB8A	63.5	41.3	90

CBG



SYMBOLS

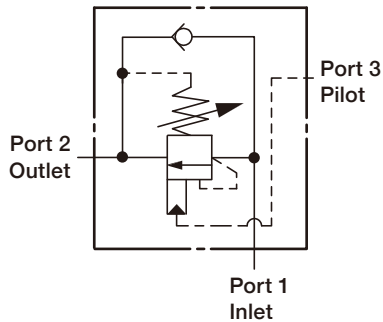

ORDER CODES

CB 2 G - T11A - L K N

1 2 3 4 5 6 7

1	▶ Model Name	CB
2	▶ Valve Size	2, 3, 6, 8
3	▶ Pilot Ratio	G 4.5:1
4	▶ Cavity	T11A, T2A, T17A, T19A
5	▶ Control Manner	L standard screw adjustment
6	▶ Adjustable Range	J 140 ~ 350 bar, w/1.7 bar check, 210 bar initially setting
		K 70 ~ 175 bar, w/1.7 bar check, 140 bar initially setting
		C 140 ~ 350 bar, w/0.3 bar check, 210 bar initially setting
		D 70 ~ 175 bar, w/0.3 bar check, 140 bar initially setting
		7
		V viton
		E EPDM
		H HNBR
		U polyurethane

MODEL SPEC.

Model	Cavity	Capacity (l/min)	Max. Pressure (bar)	Installation Torque (Nm)	Operating Temperature	Weight (kg)
CB2G	T11A	60	350	40/50	-35 ~ 100°C (-31 ~ 212°F)	0.17
CB3G	T2A	120	350	60/70		0.30
CB6G	T17A	240	350	200/215		0.64
CB8G	T19A	480	350	465/500		1.47

PERFORMANCE CURVES

► Free Flow & Piloted Open Pressure Drop

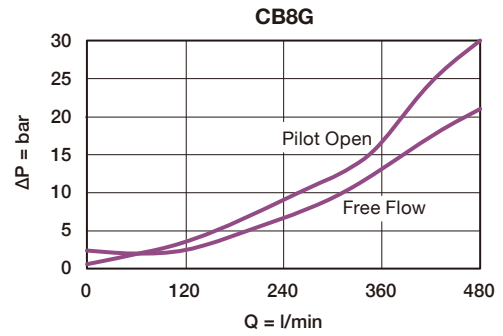
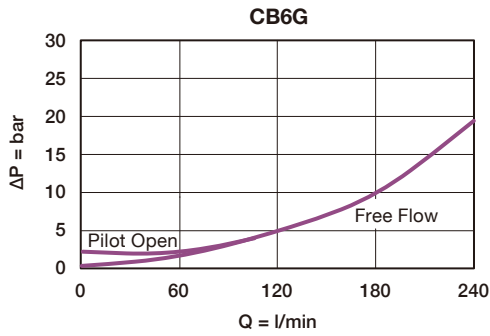
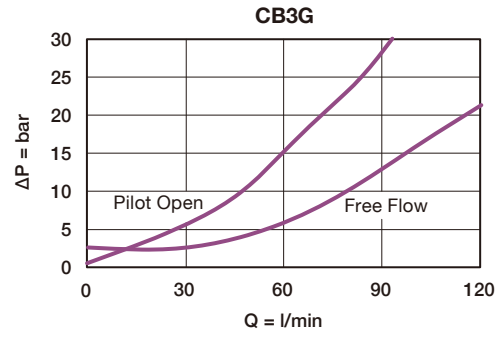
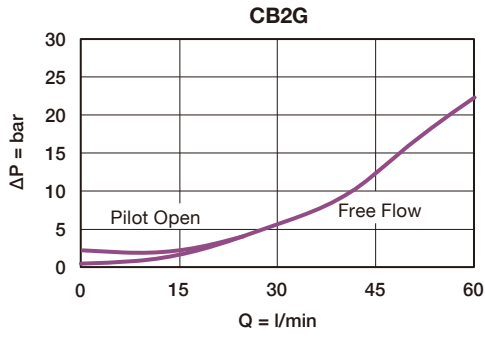

DIMENSION

(UNIT : mm)

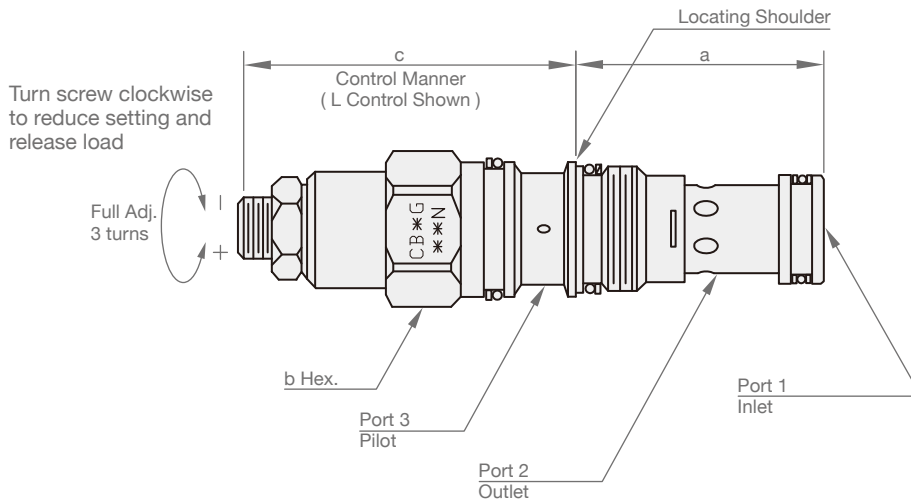

Model	a	b	c
			L
CB2G	34.9	22.2	50
CB3G	34.9	28.6	61
CB6G	46.0	31.8	70
CB8G	63.5	41.3	90

CBH



SYMBOLS

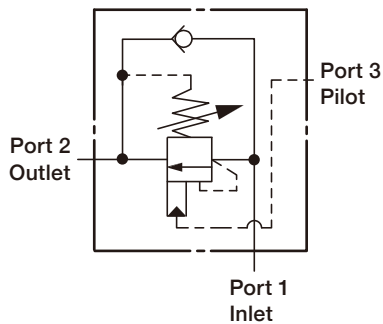

ORDER CODES

CB **2** **H** - **T11A** - **L** **K** **N**

1 2 3 4 5 6 7

1	▶ Model Name	CB
2	▶ Valve Size	2, 3, 6, 8
3	▶ Pilot Ratio	H 10:1
4	▶ Cavity	T11A, T2A, T17A, T19A
5	▶ Control Manner	L standard screw adjustment
6	▶ Adjustable Range	J 140 ~ 350 bar, w/1.7 bar check, 210 bar initially setting
		K 70 ~ 175 bar, w/1.7 bar check, 140 bar initially setting
		C 140 ~ 350 bar, w/0.3 bar check, 210 bar initially setting
		D 70 ~ 175 bar, w/0.3 bar check, 140 bar initially setting
7	▶ Material of Seal	N buna-N
		V viton
		E EPDM
		H HNBR
		U polyurethane

MODEL SPEC.

Model	Cavity	Capacity (l/min)	Max. Pressure (bar)	Installation Torque (Nm)	Operating Temperature	Weight (kg)
CB2H	T11A	60	350	40/50	-35 ~ 100°C (-31 ~ 212°F)	0.17
CB3H	T2A	120	350	60/70		0.30
CB6H	T17A	240	350	200/215		0.64
CB8H	T19A	480	350	465/500		1.47

PERFORMANCE CURVES

Free Flow & Piloted Open Pressure Drop

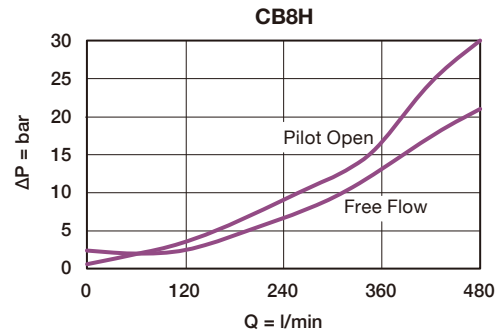
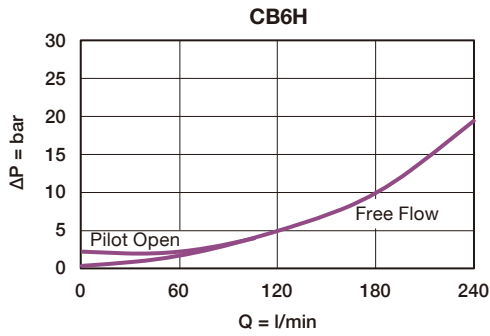
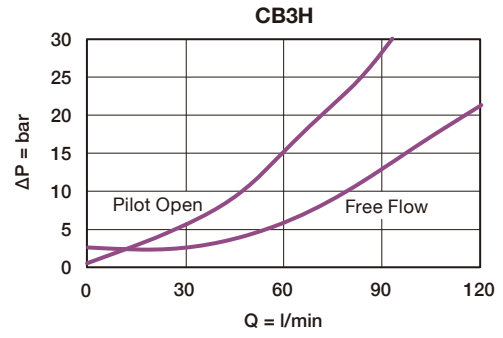
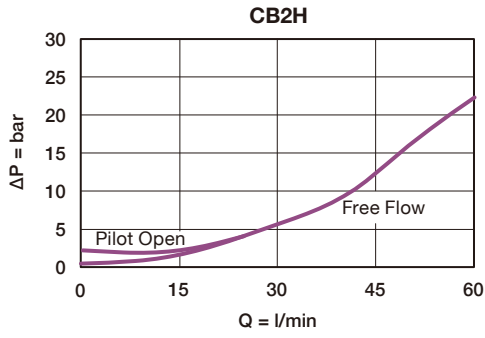

DIMENSION

(UNIT : mm)

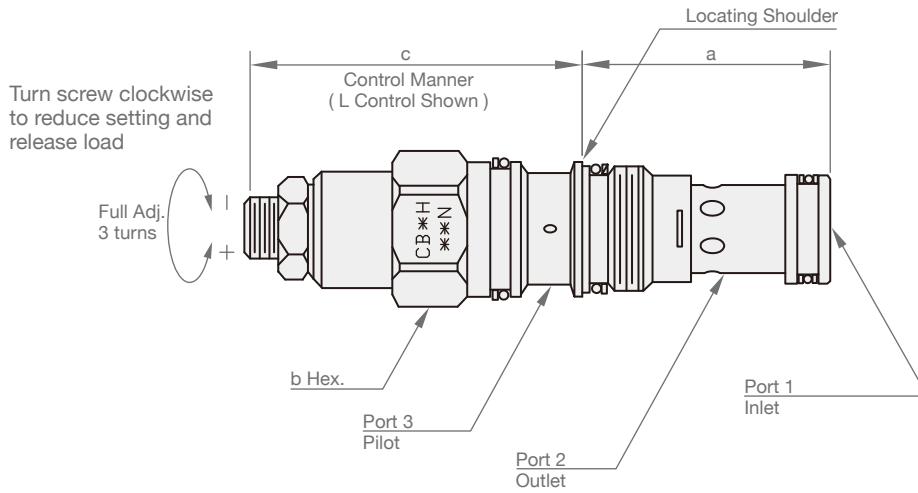

Model	a	b	c
			L
CB2H	34.9	22.2	50
CB3H	34.9	28.6	61
CB6H	46.0	31.8	70
CB8H	63.5	41.3	90

CBC



SYMBOLS

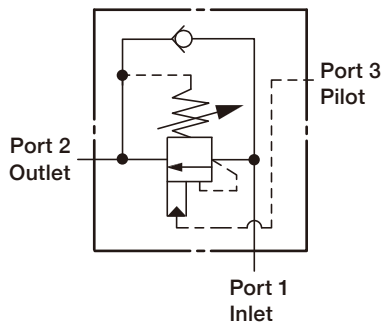

ORDER CODES

CB 2 C - T11A - L I N

1 2 3 4 5 6 7

1	▶ Model Name	CB
2	▶ Valve Size	2, 3, 6
3	▶ Pilot Ratio	C 3:1
4	▶ Cavity	T11A, T2A, T17A
5	▶ Control Manner	L standard screw adjustment
6	▶ Adjustable Range	H 70 ~ 280 bar, w/1.7 bar check, 210 bar initially setting
		I 25 ~ 105 bar, w/1.7 bar check, 70 bar initially setting
		A 70 ~ 280 bar, w/0.3 bar check, 210 bar initially setting
		B 25 ~ 105 bar, w/0.3 bar check, 70 bar initially setting
7	▶ Material of Seal	N buna-N
		V viton
		E EPDM
		H HNBR
		U polyurethane

MODEL SPEC.

Model	Cavity	Capacity (l/min)	Max. Pressure (bar)	Installation Torque (Nm)	Operating Temperature	Weight (kg)
CB2C	T11A	40	350	40/50	-35 ~ 100°C (-31 ~ 212°F)	0.17
CB3C	T2A	80	350	60/70		0.30
CB6C	T17A	160	350	200/215		0.64

PERFORMANCE CURVES

Free Flow & Piloted Open Pressure Drop

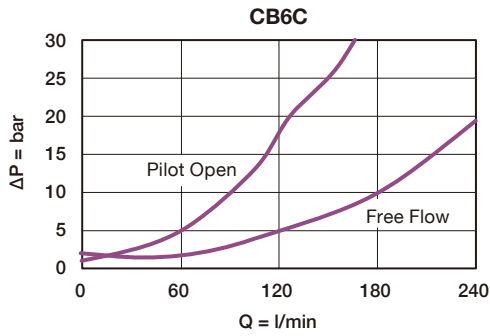
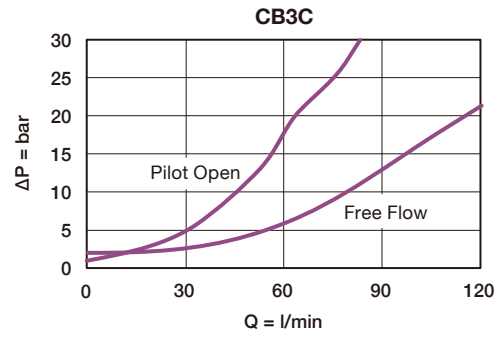
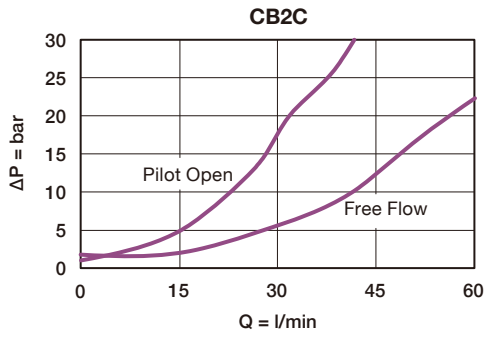

DIMENSION

(UNIT : mm)

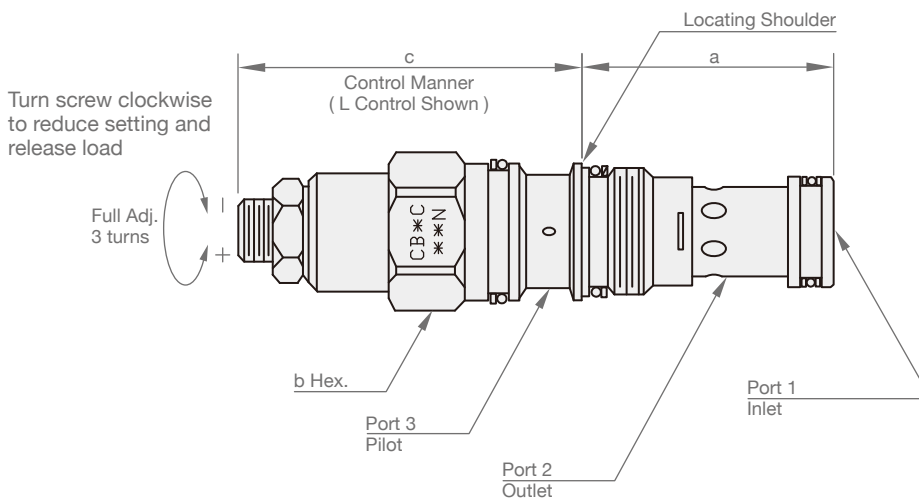

Model	a	b	c
			L
CB2C	34.9	22.2	50
CB3C	34.9	28.6	61
CB6C	46.0	31.8	70

CBD



SYMBOLS

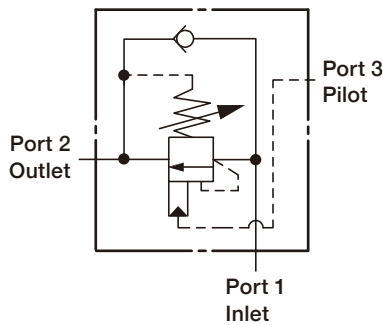

ORDER CODES

CB 2 D - T11A - L J N

1 2 3 4 5 6 7

1	▶ Model Name	CB
2	▶ Valve Size	2, 3, 6
3	▶ Pilot Ratio	D 4.5:1
4	▶ Cavity	T11A, T2A, T17A
5	▶ Control Manner	L standard screw adjustment
6	▶ Adjustable Range	J 140 ~ 350 bar, w/1.7 bar check, 210 bar initially setting
		K 70 ~ 175 bar, w/1.7 bar check, 140 bar initially setting
		C 140 ~ 350 bar, w/0.3 bar check, 210 bar initially setting
		D 70 ~ 175 bar, w/0.3 bar check, 140 bar initially setting
7	▶ Material of Seal	N buna-N
		V viton
		E EPDM
		H HNBR
		U polyurethane

MODEL SPEC.

Model	Cavity	Capacity (l/min)	Max. Pressure (bar)	Installation Torque (Nm)	Operating Temperature	Weight (kg)
CB2D	T11A	40	350	40/50	-35 ~ 100°C (-31 ~ 212°F)	0.17
CB3D	T2A	80	350	60/70		0.30
CB6D	T17A	160	350	200/215		0.64

PERFORMANCE CURVES

Free Flow & Piloted Open Pressure Drop

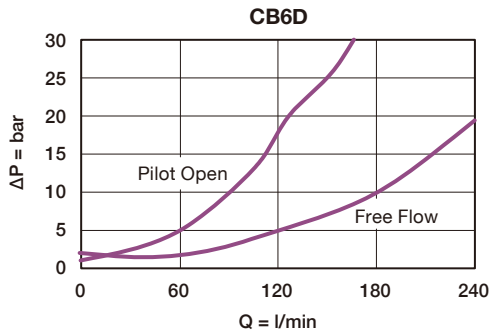
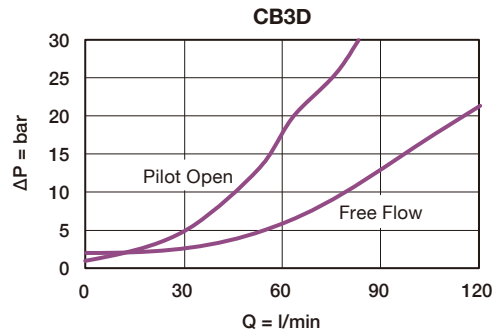
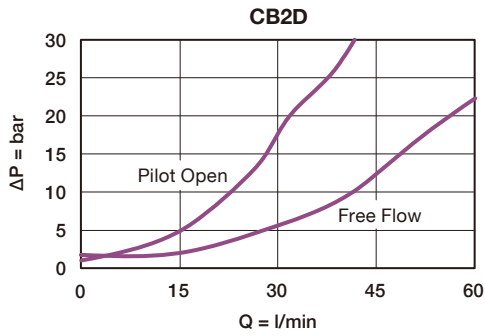

DIMENSION

(UNIT : mm)

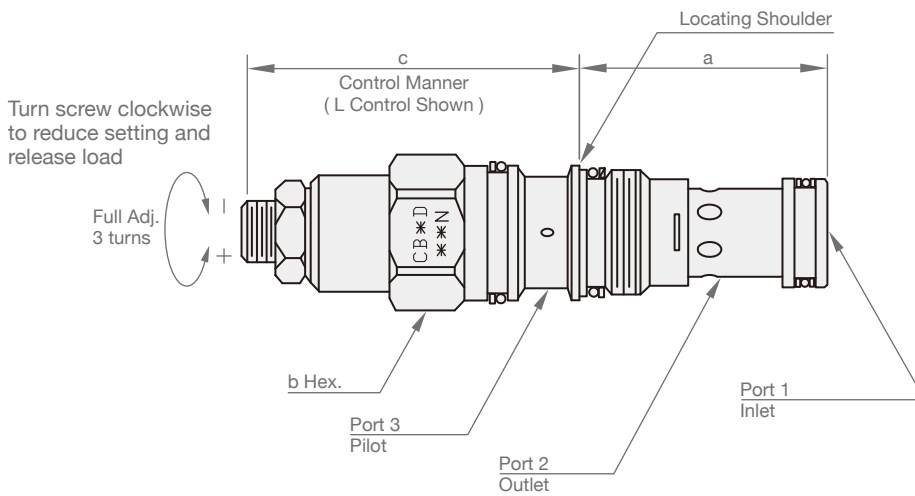

Model	a	b	c
			L
CB2D	34.9	22.2	50
CB3D	34.9	28.6	61
CB6D	46.0	31.8	70

CBE



SYMBOLS

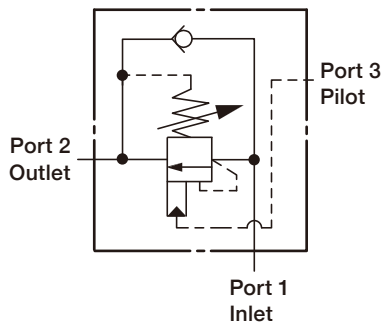

ORDER CODES

CB 2 E - T11A - L I N

1 2 3 4 5 6 7

1	▶ Model Name	CB
2	▶ Valve Size	2, 3, 6, 8
3	▶ Pilot Ratio	E 3:1
4	▶ Cavity	T11A, T2A, T17A, T19A
5	▶ Control Manner	L standard screw adjustment
6	▶ Adjustable Range	H 70 ~ 280 bar, w/1.7 bar check, 210 bar initially setting
		I 25 ~ 105 bar, w/1.7 bar check, 70 bar initially setting
		A 70 ~ 280 bar, w/0.3 bar check, 210 bar initially setting
		B 25 ~ 105 bar, w/0.3 bar check, 70 bar initially setting
7	▶ Material of Seal	N buna-N
		V viton
		E EPDM
		H HNBR
		U polyurethane

MODEL SPEC.

Model	Cavity	Capacity (l/min)	Max. Pressure (bar)	Installation Torque (Nm)	Operating Temperature	Weight (kg)
CB2E	T11A	15	350	40/50	-35 ~ 100°C (-31 ~ 212°F)	0.17
CB3E	T2A	30	350	60/70		0.30
CB6E	T17A	60	350	200/215		0.64
CB8E	T19A	80	350	465/500		1.47

PERFORMANCE CURVES

► Free Flow & Piloted Open Pressure Drop

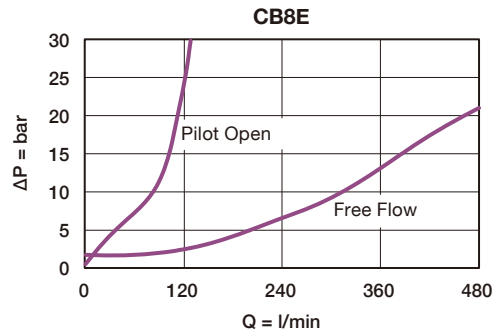
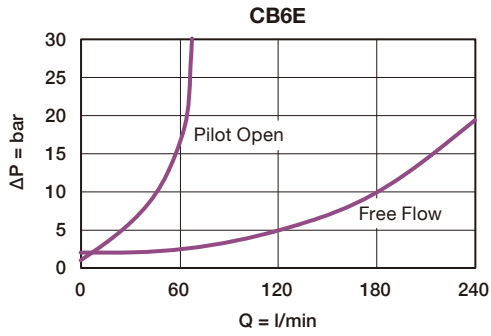
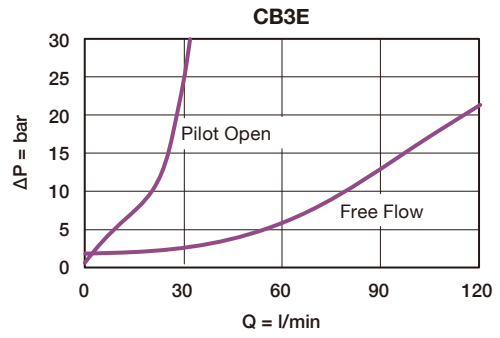
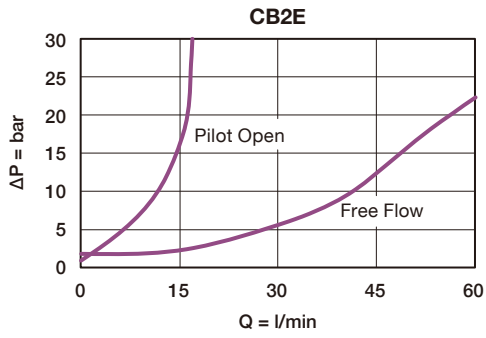

DIMENSION

(UNIT : mm)

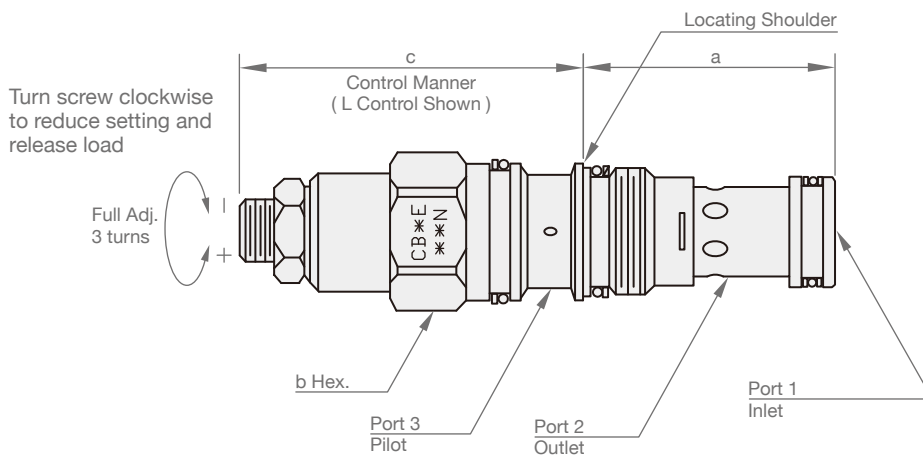

Model	a	b	c
			L
CB2E	34.9	22.2	50
CB3E	34.9	28.6	61
CB6E	46.0	31.8	70
CB8E	63.5	41.3	90

CBF



SYMBOLS

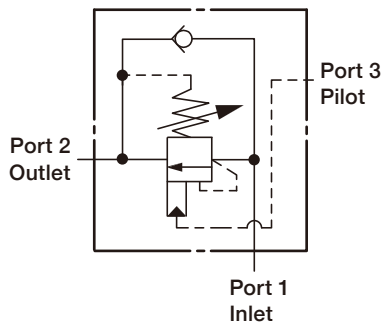

ORDER CODES

CB 2 F - T11A - L K N

1 2 3 4 5 6 7

1	▶ Model Name	CB
2	▶ Valve Size	2, 3, 6, 8
3	▶ Pilot Ratio	F 4.5:1
4	▶ Cavity	T11A, T2A, T17A, T19A
5	▶ Control Manner	L standard screw adjustment
6	▶ Adjustable Range	J 140 ~ 350 bar, w/1.7 bar check, 210 bar initially setting
		K 70 ~ 175 bar, w/1.7 bar check, 140 bar initially setting
		C 140 ~ 350 bar, w/0.3 bar check, 210 bar initially setting
		D 70 ~ 175 bar, w/0.3 bar check, 140 bar initially setting
7	▶ Material of Seal	N buna-N
		V viton
		E EPDM
		H HNBR
		U polyurethane

MODEL SPEC.

Model	Cavity	Capacity (l/min)	Max. Pressure (bar)	Installation Torque (Nm)	Operating Temperature	Weight (kg)
CB2F	T11A	15	350	40/50	-35 ~ 100°C (-31 ~ 212°F)	0.17
CB3F	T2A	30	350	60/70		0.30
CB6F	T17A	60	350	200/215		0.64
CB8F	T19A	80	350	465/500		1.47

PERFORMANCE CURVES

► Free Flow & Piloted Open Pressure Drop

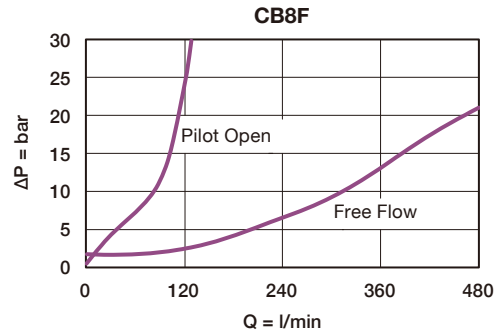
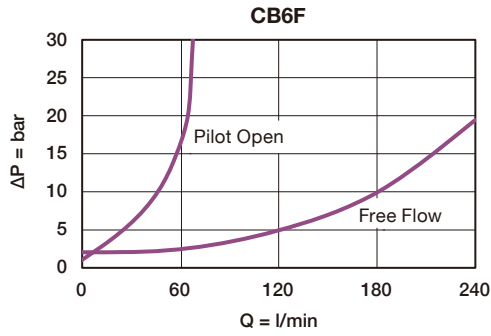
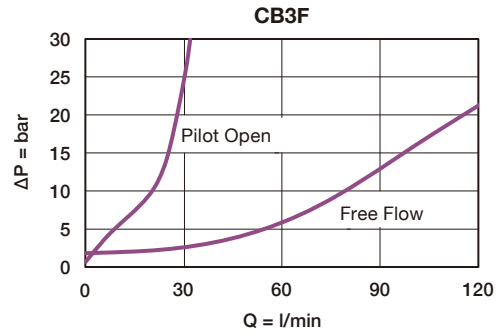
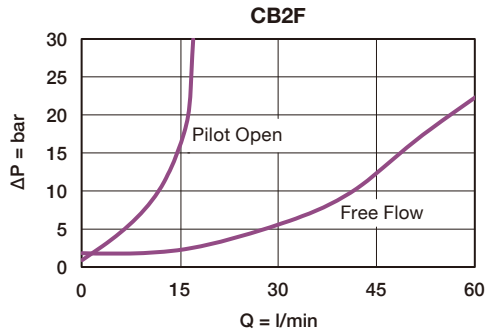

DIMENSION

(UNIT : mm)

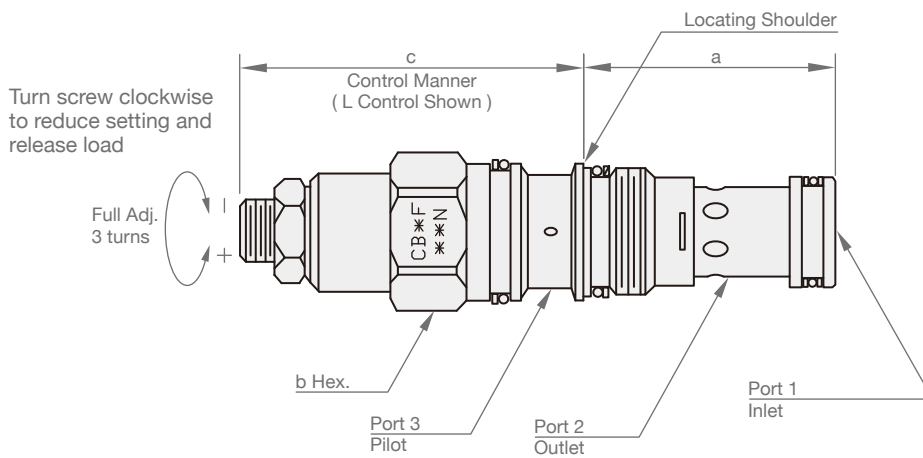

Model	a	b	c
			L
CB2F	34.9	22.2	50
CB3F	34.9	28.6	61
CB6F	46.0	31.8	70
CB8F	63.5	41.3	90

CWA



SYMBOLS

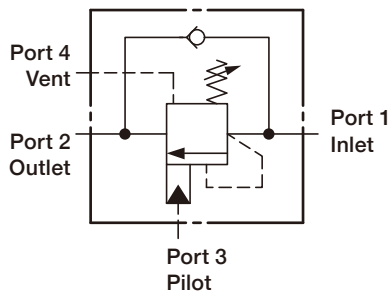

ORDER CODES

CW **2** **A** - **T21A** - **L** **I** **N**

1 2 3 4 5 6 7

1	▶ Model Name	CW	
2	▶ Valve Size	2, 3, 6, 8	
3	▶ Pilot Ratio	A	3:1
4	▶ Cavity	T21A, T22A, T23A, T24A	
5	▶ Control Manner	L	standard screw adjustment
6	▶ Adjustable Range	H	70 ~ 280 bar, 210 bar initially setting
		I	25 ~ 105 bar, 70 bar initially setting
7	▶ Material of Seal	N	buna-N
		V	viton
		E	EPDM
		H	HNBR
		U	polyurethane

MODEL SPEC.

Model	Cavity	Capacity (l/min)	Max. Pressure (bar)	Installation Torque (Nm)	Operating Temperature	Weight (kg)
CW2A	T21A	60	350	45/50	-35 ~ 100°C (-31 ~ 212°F)	0.19
CW3A	T22A	120	350	60/70		0.36
CW6A	T23A	240	350	200/215		0.72
CW8A	T24A	480	350	465/500		1.60

PERFORMANCE CURVES

► Free Flow & Piloted Open Pressure Drop

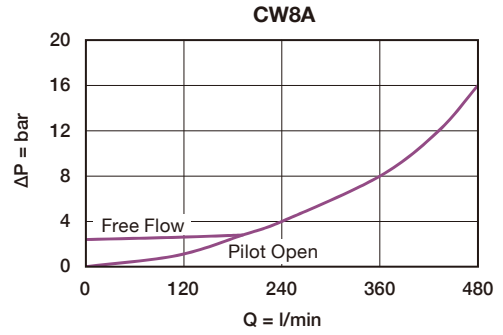
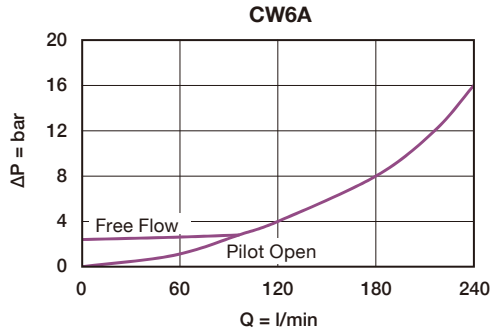
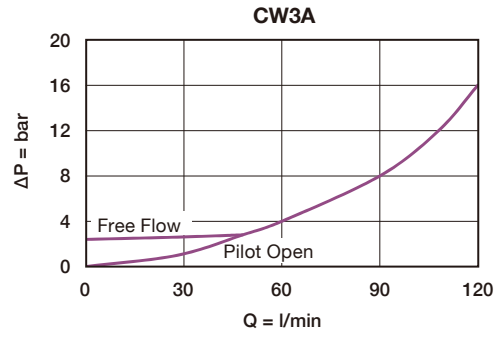
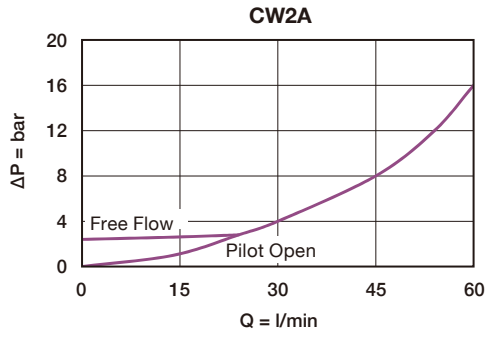

DIMENSION

(UNIT : mm)

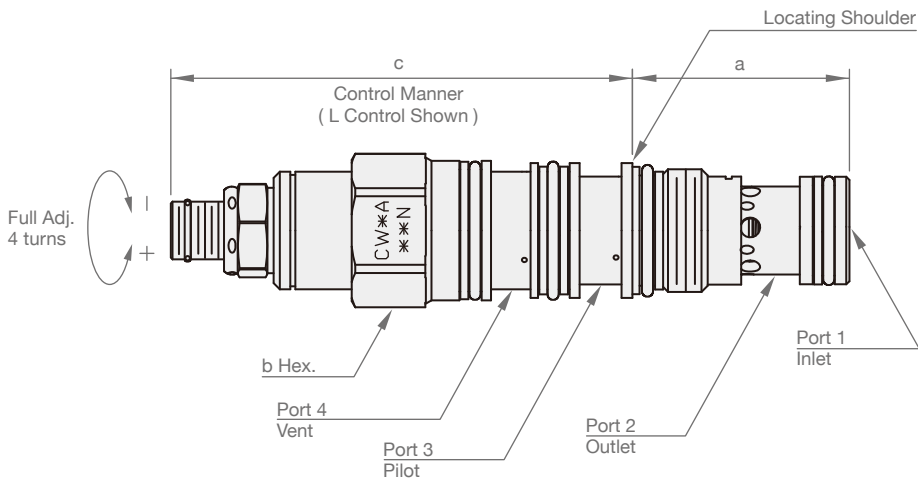

Model	a	b	c
			L
CW2A	34.9	22.2	74.0
CW3A	34.9	28.6	84.0
CW6A	46.0	31.8	95.3
CW8A	63.5	41.3	117.0

CWG



SYMBOLS

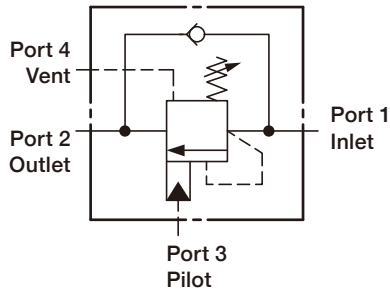

ORDER CODES

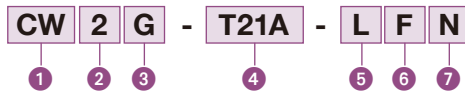

1	Model Name	CW	
2	Valve Size	2, 3, 6, 8	
3	Pilot Ratio	G	5:1
4	Cavity	T21A, T22A, T23A, T24A	
5	Control Manner	L	standard screw adjustment
6	Adjustable Range	G	140 ~ 420 bar, 280 bar initially setting
		F	70 ~ 175 bar, 140 bar initially setting
7	Material of Seal	N	buna-N
		V	viton
		E	EPDM
		H	HNBR
		U	polyurethane

MODEL SPEC.

Model	Cavity	Capacity (l/min)	Max. Pressure (bar)	Installation Torque (Nm)	Operating Temperature	Weight (kg)
CW2G	T21A	60	350	45/50	-35 ~ 100°C (-31 ~ 212°F)	0.19
CW3G	T22A	120	350	60/70		0.36
CW6G	T23A	240	350	200/215		0.72
CW8G	T24A	480	350	465/500		1.60

PERFORMANCE CURVES

► Free Flow & Piloted Open Pressure Drop

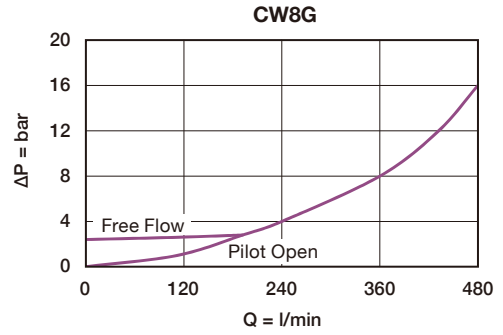
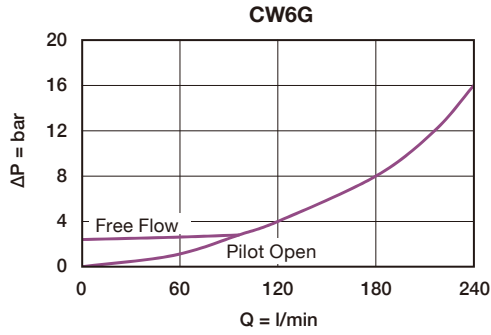
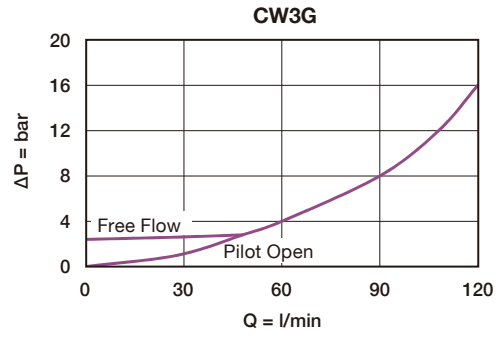
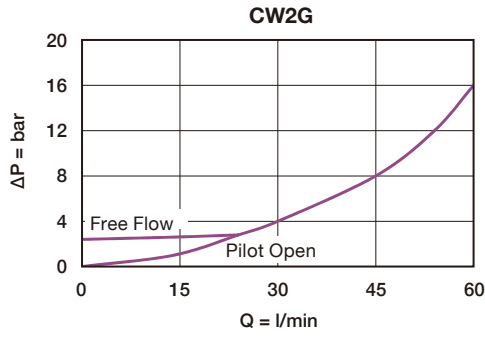

DIMENSION

(UNIT : mm)

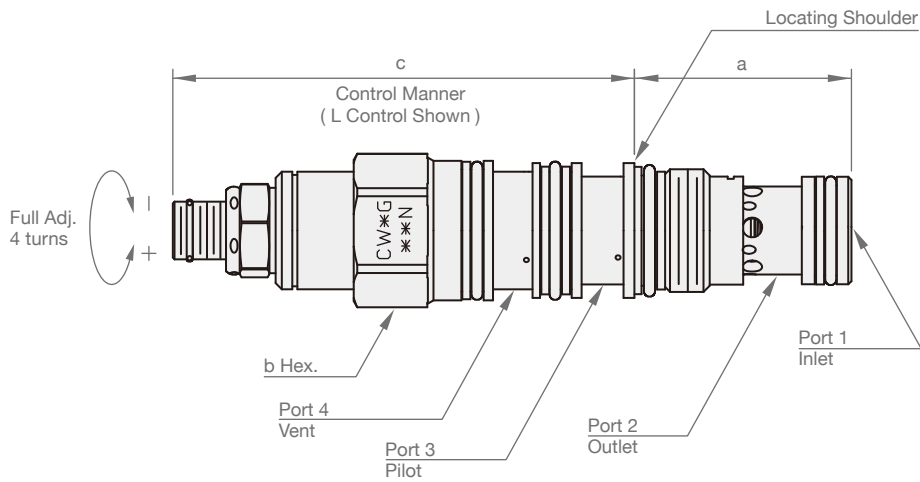

Model	a	b	c
			L
CW2G	34.9	22.2	74.0
CW3G	34.9	28.6	84.0
CW6G	46.0	31.8	95.3
CW8G	63.5	41.3	117.0

LO



ORDER CODES

LO 2 C - T11A - X D N

1 2 3 4 5 6 7

1	▶ Model Name	LO
2	▶ Valve Size	2, 3, 6, 8
3	▶ Operation	A, B, C, D, O
4	▶ Cavity	T11A, T2A, T17A, T19A
5	▶ Control Manner	X unadjustable L standard screw adjustment

6	▶ Cracking Pressure (bar)	D	Type A, B, C, D, Port 1 : 3.5 Type O, Port 3 : 2
7	▶ Material of Seal	N	buna-N
		V	viton
		E	EPDM
		H	HNBR
		U	polyurethane

SYMBOLS

LO*A	LO*B	LO*C	LO*D	LO*O
Vent-to-Open	Vent-to-Open	Pilot-to-Close	Vent-to-Open	Pilot-to-Close
Spring biased closed, pilot source from port 1	Spring biased closed, pilot source from port 2	Spring biased closed, pilot source from port 3	Spring biased closed, higher of port 1 or 2 pilot source	Spring biased open, pilot source from port 3

MODEL SPEC.

Model	Cavity	Capacity (l/min)	Max. Pressure (bar)	Installation Torque (Nm)	Control Orifice Diameter (mm)	Operating Temperature	Weight (kg)
LO2*	T11A	80	350	40/50	Ø0.5	-35 ~ 100°C (-31 ~ 212°F)	0.12
LO3*	T2A	160	350	60/70	Ø0.5		0.22
LO6*	T17A	320	350	200/215	Ø0.8		0.50
LO8*	T19A	640	350	465/500	Ø0.9		1.15

Area ratio, A3 to A1 : 1.8:1 (with sealed piston)

Area ratio, A3 to A2 : 2.25:1 (with sealed piston)

PERFORMANCE CURVES

► Typical Pressure Drop

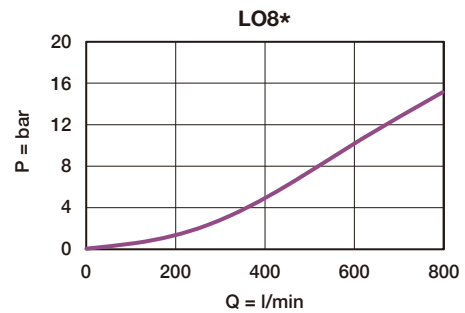
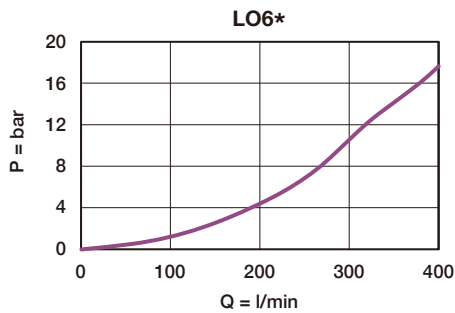
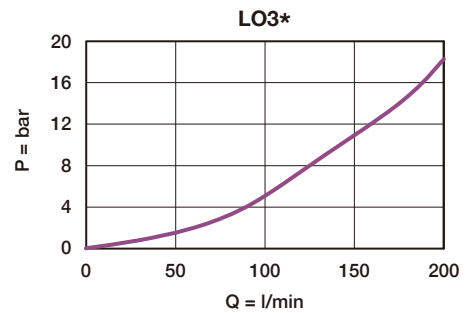
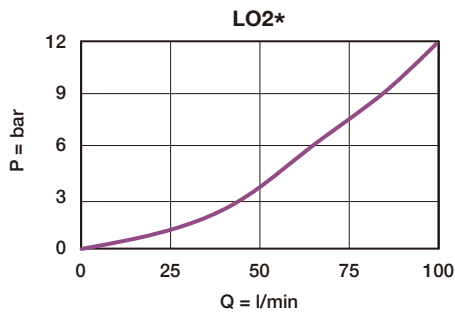

DIMENSION

(UNIT : mm)

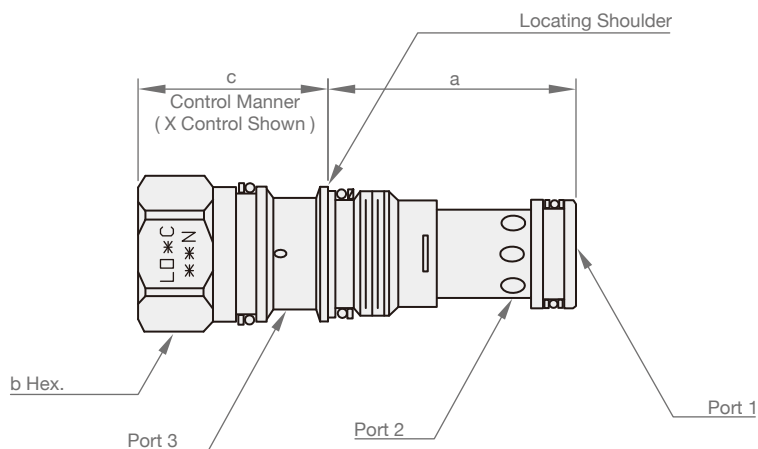

Model	a	b	c	
			X	L
LO2*	34.9	22.2	31	64
LO3*	34.9	28.6	35	72
LO6*	46.0	31.8	46	84
LO8*	63.5	41.3	59	100

LP



SYMBOLS

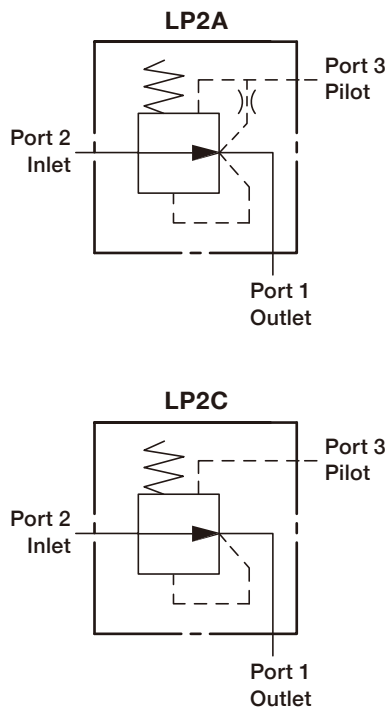

ORDER CODES

LP 2 C - T11A - X D N

1 2 3 4 5 6 7

1	▶ Model Name	LP
2	▶ Valve Size	2, 3, 6, 8
3	▶ Type	A internal pilot C external pilot
4	▶ Cavity	T11A, T2A, T17A, T19A
5	▶ Control Manner	X unadjustable L standard screw adjustment
6	▶ Cracking Pressure	D 3.5 bar F 7.0 bar G 10.0 bar H 14.0 bar
7	▶ Material of Seal	N buna-N V viton E EPDM H HNBR U polyurethane

MODEL SPEC.

Model	Cavity	Capacity (l/min)	Max. Pressure (bar)	Installation Torque (Nm)	Operating Temperature	Weight (kg)
LP2A, LP2C	T11A	60	350	45/50	-35 ~ 100°C (-31 ~ 212°F)	0.15
LP3A, LP3C	T2A	120	350	60/70		0.25
LP6A, LP6C	T17A	240	350	200/215		0.55
LP8A, LP8C	T19A	480	350	465/500		1.17

PERFORMANCE CURVES

► Capacity as a Restrictive Compensator

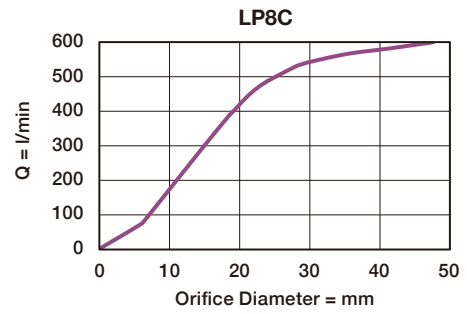
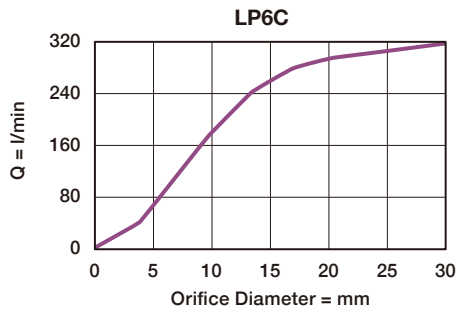
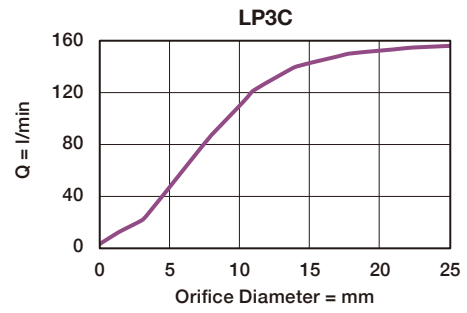
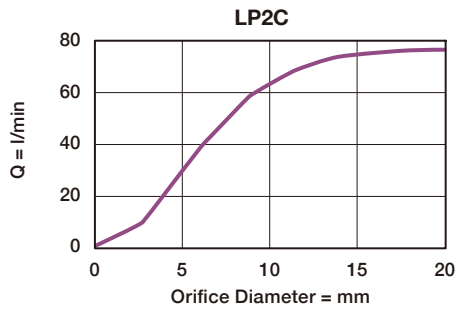

DIMENSION

(UNIT : mm)

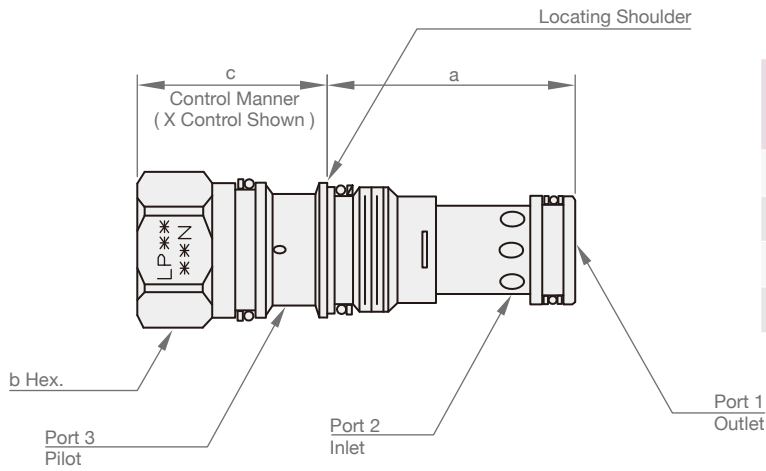

Model	a	b	c	
			X	L
LP2*	34.9	22.2	31	64
LP3*	34.9	28.6	35	72
LP6*	46.0	31.8	46	84
LP8*	63.5	41.3	59	100

FQ



SYMBOLS

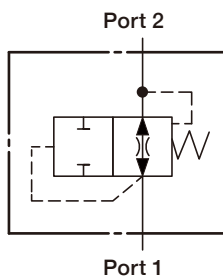

ORDER CODES

FQ **2A** - **T13A** - **X** **A** **N**

1 2 3 4 5 6

1	▶ Model Name	FQ
2	▶ Valve Size	2A, 3A, 6A, 8A
3	▶ Cavity	T13A, T5A, T16A, T18A
4	▶ Control Manner	X unadjustable
5	▶ Orifice Type	A replaceable
		B permanent
6	▶ Material of Seal	N buna-N
		V viton
		E EPDM
		H HNBR
		U polyurethane

MODEL SPEC.

Model	Cavity	Capacity (l/min)	Max. Pressure (bar)	Installation Torque (Nm)	Operating Temperature	Weight (kg)
FQ2A	T13A	23	350	45/50	-35 ~ 100°C (-31 ~ 212°F)	0.10
FQ3A	T5A	60	350	60/70		0.19
FQ6A	T16A	95	350	200/215		0.46
FQ8A	T18A	200	350	465/500		0.92

PERFORMANCE CURVES

► Typical Pressure Drop

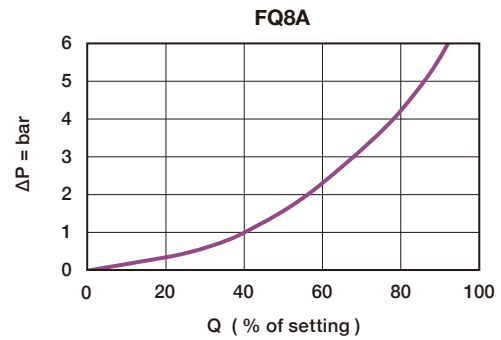
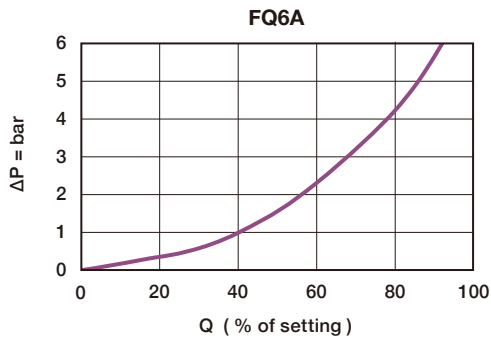
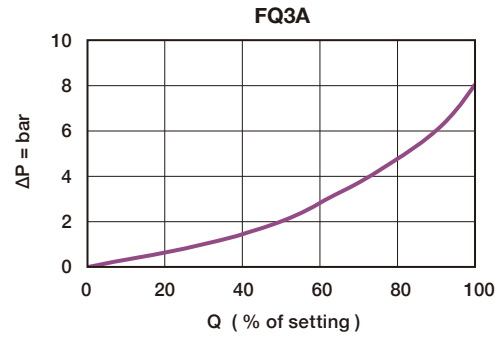
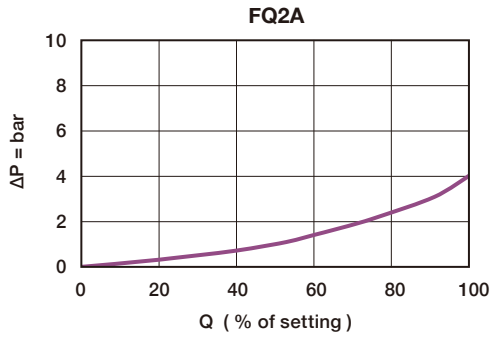

DIMENSION

(UNIT : mm)

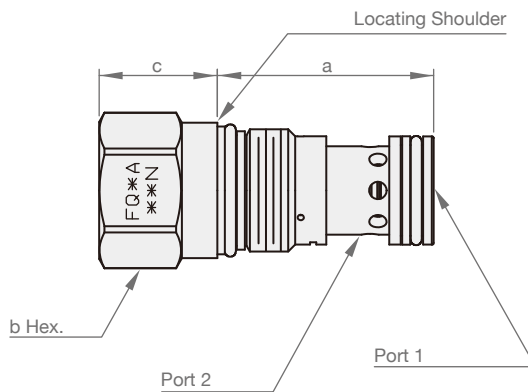

Model	a	b	c
			X
FQ2A	35.1	22.2	19.1
FQ3A	41.1	28.6	17.5
FQ6A	62.0	31.8	24.6
FQ8A	79.5	41.3	30.2

COA



SYMBOLS

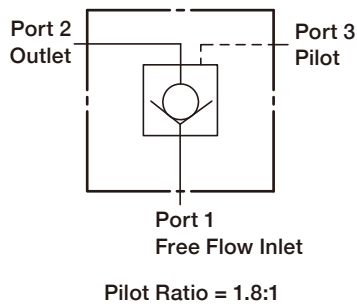

ORDER CODES

CO **2** **A** - **T11A** - **X** **C** **N**

1 2 3 4 5 6 7

1	▶ Model Name	CO	
2	▶ Valve Size	1, 2, 3, 6, 8	
3	▶ Pilot Ratio	A	1.8:1
4	▶ Cavity	T163A, T11A, T2A, T17A, T19A	
5	▶ Control Manner	X	standard pilot
6	▶ Cracking Pressure	A	0.3 bar
		C	2.0 bar
		E	5.0 bar
7	▶ Material of Seal	N	buna-N
		V	viton
		E	EPDM
		H	HNBR
		U	polyurethane

MODEL SPEC.

Model	Cavity	Capacity (l/min)	Max. Pressure (bar)	Installation Torque (Nm)	Operating Temperature	Weight (kg)
CO1A	T163A	40	350	30/40	-35 ~ 100°C (-31 ~ 212°F)	0.10
CO2A	T11A	80	350	40/50		0.13
CO3A	T2A	160	350	60/70		0.24
CO6A	T17A	320	350	200/215		0.53
CO8A	T19A	640	350	465/500		1.19

PERFORMANCE CURVES

► Typical Pressure Drop

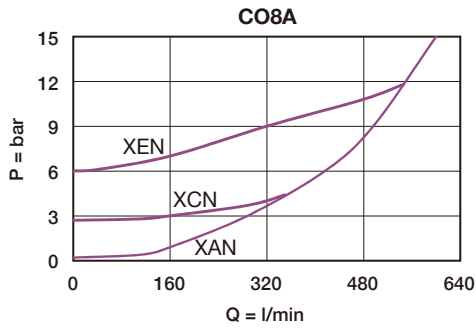
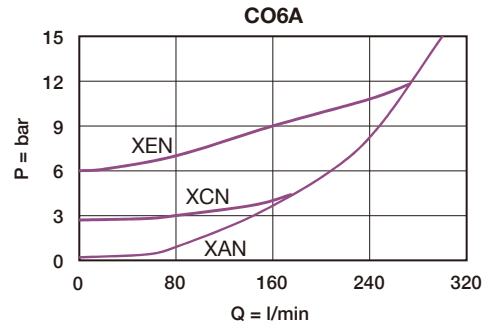
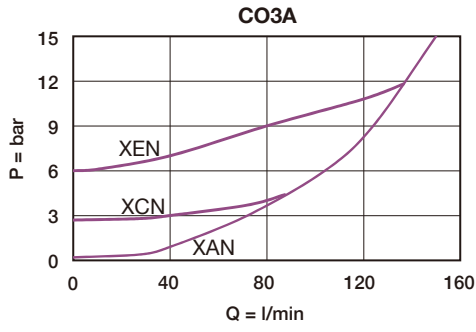
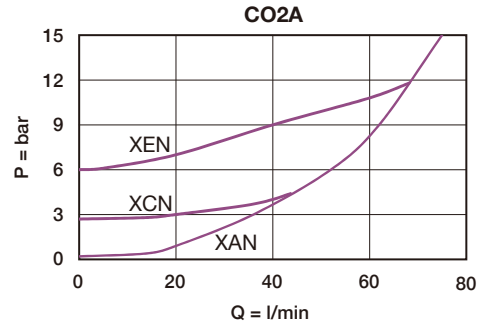
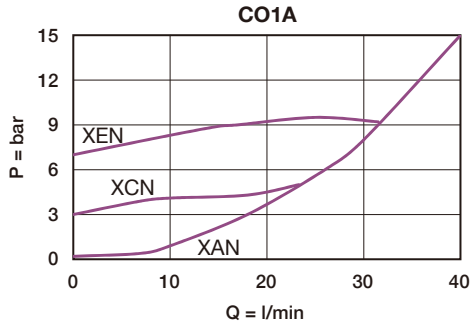

DIMENSION

(UNIT : mm)

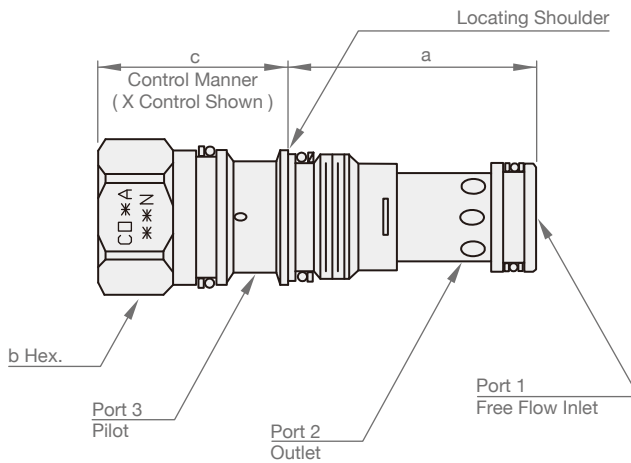

Model	a	b	c
			X
CO1A	31.0	19.1	32
CO2A	34.9	22.2	31
CO3A	34.9	28.6	35
CO6A	46.0	31.8	46
CO8A	63.5	41.3	59

COO



SYMBOLS

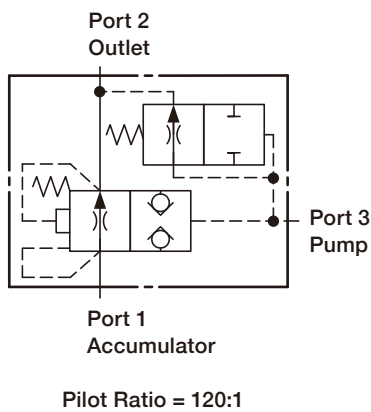

ORDER CODES

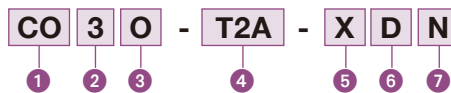

1	Model Name	CO	
2	Valve Size	3	
3	Pilot Ratio	O	120:1
4	Cavity	T2A	
5	Control Manner	X	standard pilot
6	Min. Pilot Pressure	D	4 bar
7	Material of Seal	N	buna-N
		V	viton
		E	EPDM
		H	HNBR
		U	polyurethane

MODEL SPEC.

Model	Cavity	Capacity (l/min)	Max. Pressure (bar)	Installation Torque (Nm)	Operating Temperature	Weight (kg)
CO3O	T2A	4	350	60/70	-35 ~ 100°C (-31 ~ 212°F)	0.22

PERFORMANCE CURVES

► Pressure Differential v.s. Flow

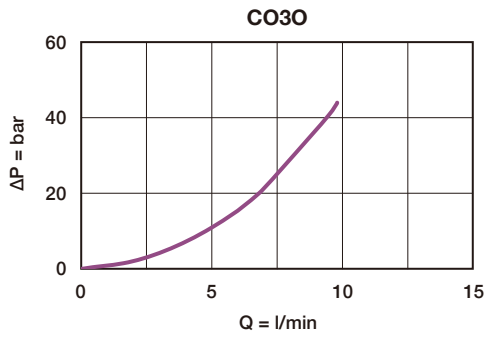

DIMENSION

(UNIT : mm)

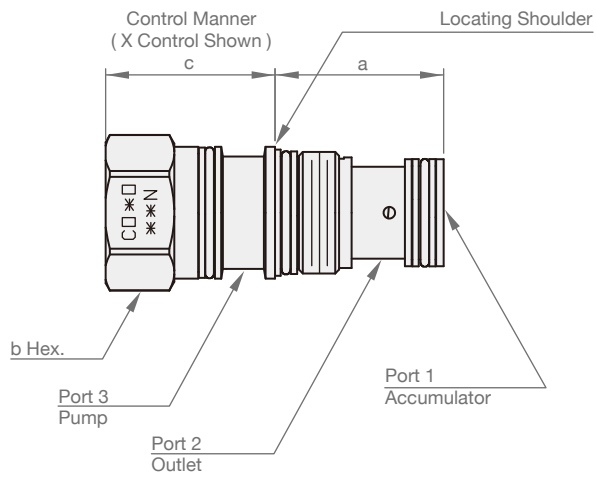

Model	a	b	c
			X
CO30	35.1	28.6	35.1

QC



SYMBOLS

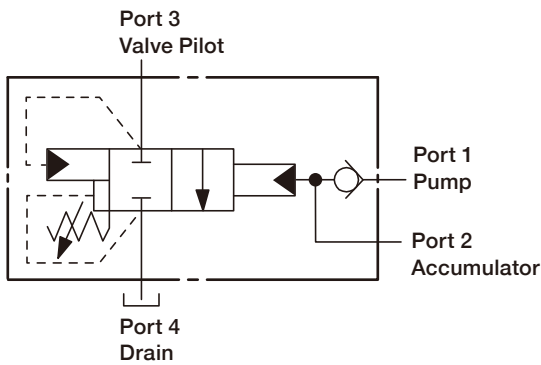

ORDER CODES

QC **2** **C** - **T21A** - **L** **A** **N**

1 2 3 4 5 6 7

1	Model Name	QC	
2	Capacity	2	60
3	Pressure Differential Ratio btw. Unload & Reset	A	10%
		B	15%
		C	30%
4	Cavity	T21A	
5	Control Manner	L	standard screw adjustment
		K	hand knob with lock knob
6	Adjustable Range	A	7 ~ 210 bar
		B	3.5 ~ 105 bar
		C	140 ~ 350 bar
		D	18 ~ 55 bar
7	Material of Seal	N	buna-N
		V	viton
		E	EPDM
		H	HNBR
		U	polyurethane

MODEL SPEC.

Model	Cavity	Capacity (l/min)	Max. Pressure (bar)	Installation Torque (Nm)	Operating Temperature	Weight (kg)
QC2*	T21A	60	350	60/70	-35 ~ 100°C (-31 ~ 212°F)	0.22

PERFORMANCE CURVES

► Pressure Differential vs. Flow

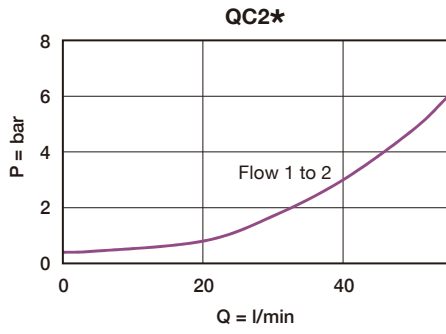

► Pressure Differential vs. Flow (Full Piloted Open)

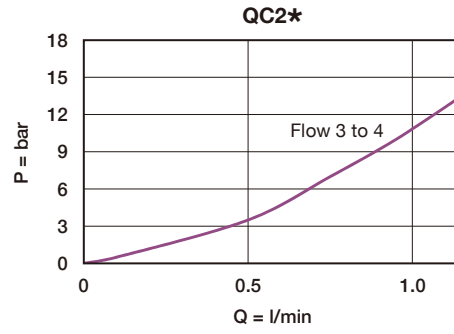

DIMENSION

(UNIT : mm)

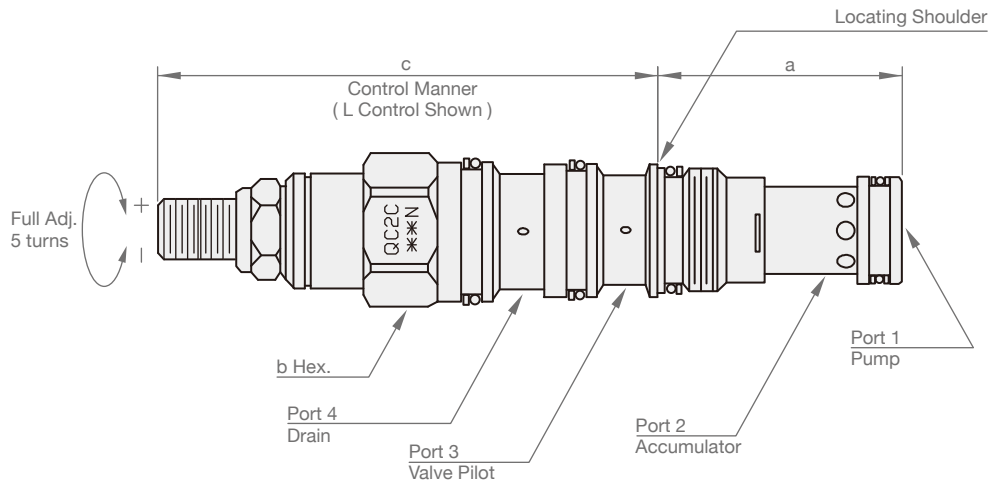

Model	a	b	c	
			L	K
QC2C	34.9	22.2	78.5	84.8

OA2

SYMBOLS

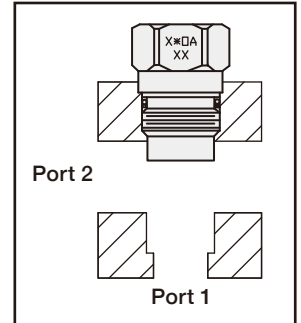
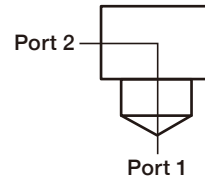

MODEL SPEC.

Model	Cavity	Thread	Material of Seal	Weight (kg)
X10A2-T162A-XX	T162A	M16 P1.5	buna-N	0.05
X20A2-T10A-XX	T10A	M20 P1.5		0.09
X20A2-T13A-XX	T13A	M20 P1.5		0.09
X30A2-T3A-XX	T3A	1"-14UNS-2B		0.13
X30A2-T5A-XX	T5A	1"-14UNS-2B		0.13
X60A2-T16A-XX	T16A	M36 P2		0.28
X80A2-T18A-XX	T18A	M48 P2		0.57

DIMENSION

(UNIT : mm)

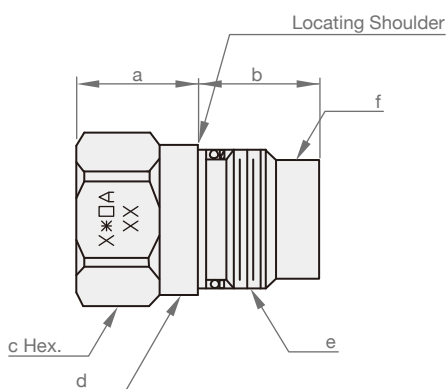

Model	a	b	c	d	e	f
X20A2	20.3	16.3	22.2	Ø21.7	M16 P1.5-6H	Ø17.4
X30A2	17.8	22.2	28.6	Ø27.3	1"-14UNS-2B	Ø22.6
X60A2	26	25	31.7	Ø39.7	M36 P2.0-6H	Ø33
X80A2	30.4	26.8	41.2	Ø52.5	M48 P2.0-6H	Ø43

CA2

SYMBOLS

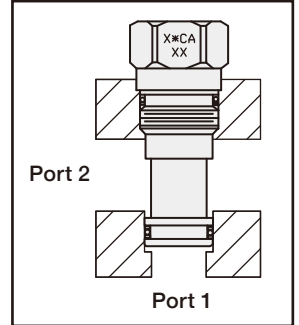
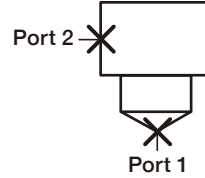

MODEL SPEC.

Model	Cavity	Thread	Material of Seal	Weight (kg)
X1CA2-T162A-XX	T162A	M16 P1.5	buna-N	0.07
X2CA2-T10A-XX	T10A	M20 P1.5		0.12
X2CA2-T13A-XX	T13A	M20 P1.5		0.12
X3CA2-T3A-XX	T3A	1"-14UNS-2B		0.21
X3CA2-T5A-XX	T5A	1"-14UNS-2B		0.20
X6CA2-T16A-XX	T16A	M36 P2		0.49
X8CA2-T18A-XX	T18A	M48 P2		1.10

DIMENSION

(UNIT : mm)

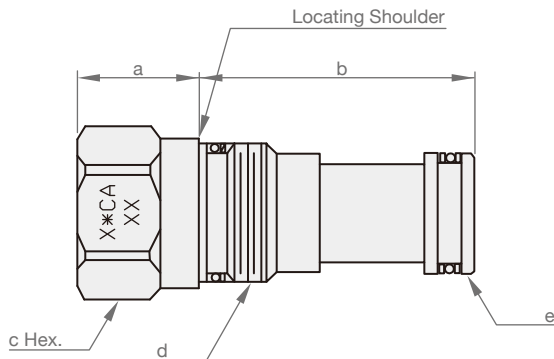

Model	a	b	c	d	e
X2CA2	20.2	38.2	22.2	M16 P1.5-6H	Ø17.4
X3CA2	17.8	47.7	28.6	1"-14UNS-2B	Ø22.2
X6CA2	25.7	60.8	31.7	M32 P2.0-6H	Ø31.7
X8CA2	30	79.6	41.2	M48 P2.0-6H	Ø41.2

OA3

SYMBOLS

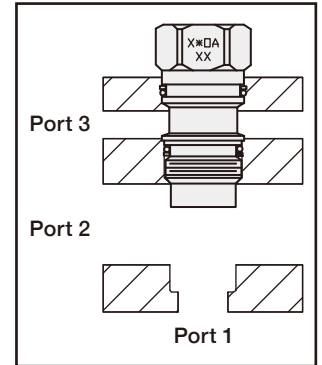
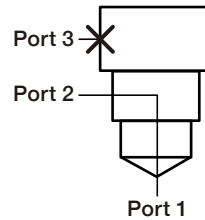

MODEL SPEC.

Model	Cavity	Thread	Material of Seal	Weight (kg)
X10A3-T163A-XX	T163A	M16 P1.5	buna-N	0.06
X20A3-T11A-XX	T11A	M20 P1.5		0.09
X30A3-T2A-XX	T2A	1"-14UNS-2B		0.16
X60A3-T17A-XX	T17A	M36 P2		0.31
X80A3-T19A-XX	T19A	M48 P2		0.68

DIMENSION

(UNIT : mm)

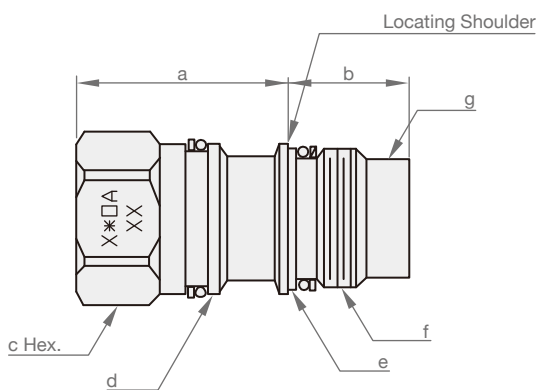

Model	a	b	c	d	e	f	g
X10A3	31.86	14.54	19.1	Ø17.8	Ø16.6	M16 P1.5-6H	Ø13.9
X20A3	30	17.8	22.2	Ø21.7	Ø20.5	M16 P1.5-6H	Ø17.4
X30A3	35.2	15.2	28.6	Ø27.3	Ø26	1"-14UNS-2B	Ø22.8
X60A3	46.2	18.3	31.6	Ø39.6	Ø36.4	M36 P2.0-6H	Ø32.5
X80A3	59	23.5	41	Ø52.4	Ø48.2	M36 P2.0-6H	Ø43

CA3

SYMBOLS

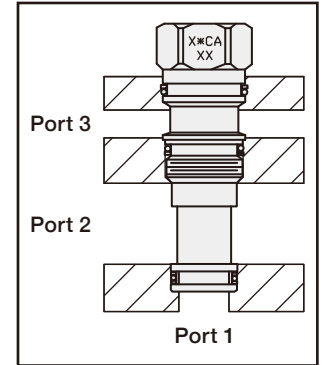
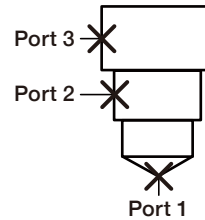

MODEL SPEC.

Model	Cavity	Thread	Material of Seal	Weight (kg)
X1CA3-T163A-XX	T163A	M16 P1.5	buna-N	0.08
X2CA3-T11A-XX	T11A	M20 P1.5		0.12
X3CA3-T2A-XX	T2A	1"-14UNS-2B		0.22
X6CA3-T17A-XX	T17A	M36 P2		0.52
X8CA3-T19A-XX	T19A	M48 P2		1.20

DIMENSION

(UNIT : mm)

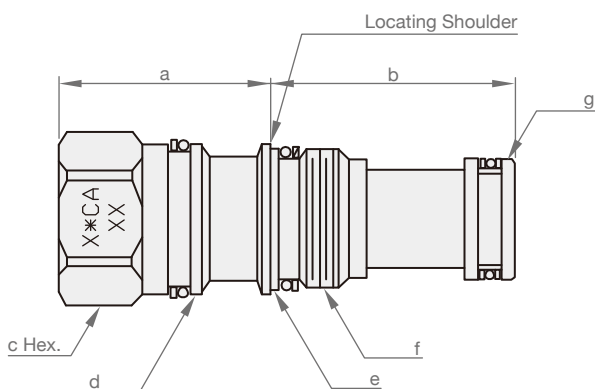

Model	a	b	c	d	e	f	g
X1CA3	32	31	19.1	Ø17.8	Ø16.6	M16 P1.5-6H	Ø13.9
X2CA3	30.5	34.8	22.2	Ø21.8	Ø20.5	M16 P1.5-6H	Ø17.3
X3CA3	35	35	28.6	Ø27.3	Ø26	1"-14UNS-2B	Ø22.1
X6CA3	46.4	46	31.6	Ø39.6	Ø36.4	M36 P2.0-6H	Ø31.6
X8CA3	46.4	46	31.6	Ø39.6	Ø36.4	M36 P2.0-6H	Ø31.6

SY-DPCA-C-1



FEATURES

1. Precise Control
Digital microprocessor
2. Simple Setup
Digital display and buttons
3. Full Function
Adjustable input signal and output current
4. Safety
Short, open circuit protection with error code

ORDER CODES

SY - **DPCA** - **C** - **1**

1
2
3
4

1	▶ Model Name	SY	
2	▶ Control Mode	DPCA	digital proportional controller
3	▶ Type	C	case with DIN-35 rail clamps
4	▶ Output	1	single coil

MODEL SPEC.

Model	SY-DPCA-C-1
Operating Voltage	9 ~ 32VDC
Voltage Tolerance	5%
Input Signal Options	0~5V, 0~10V, 4~20mA, RS485
Output Current	3A max.
Dither Frequency	70 ~ 350Hz
Ramp Up and Down	0.1 ~ 5.0s
Reference Voltage	5V (max. current 5mA)
Communication Interface	RS485
Communication Protocol	Modbus RTU
Operating Conditions	-20 ~ 60°C
Weight	0.1kg

Wiring Instruction

1	VS-	Power-
2	VS+	Power+
3	Out+	Coil+
4	Out-	Coil-
5	Vi+	Input voltage signal
6	Vi- li-	Signal ground
7	li+	Input current signal
8	Enable	Enable *
9	Vref +5V	+5V reference voltage
10	D+	RS485+ (optional)
11	D-	RS485- (optional)

* Default off. Ground this pin to enable controller when PEA function is on.

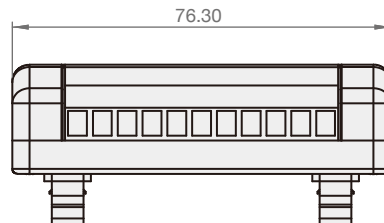
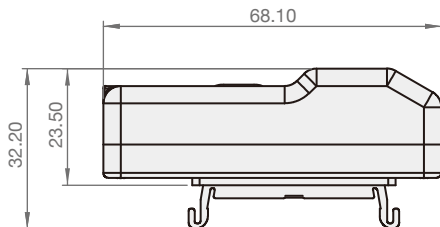
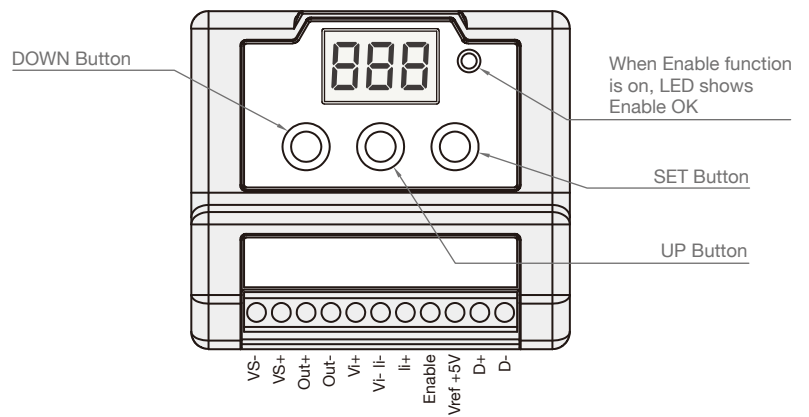
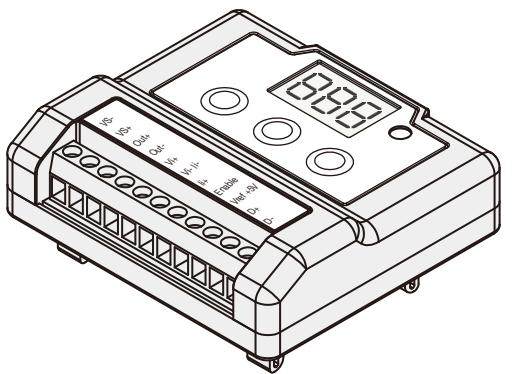

* A USB-RS485 converter (Purchase separately) is necessary to connect PC.

** Using a USB-RS485 converter, you can operate and configure parameters via the PC software provided by our company.

Please mail us to get the PC software : info@steadmachinery.com.tw.



This product has been designed and tested to meet specific standards outlined in the European Electromagnetic Compatibility Directive (EMC)2014/30/EU.

Emission: EN 61000-6-4:2019

Immunity: EN 61000-6-2:2019; EN 61000-4-2:2009, EN 61000-4-3:2020, EN 61000-4-8:2010

Certificate No. NE1105240044

SY-DPCA-P-1

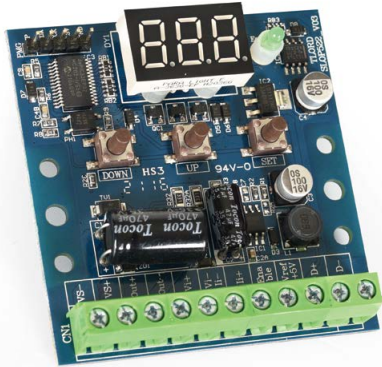

FEATURES

1. Precise Control
Digital microprocessor
2. Simple Setup
Digital display and buttons
3. Full Function
Adjustable input signal and output current
4. Safety
Short, open circuit protection with error code

ORDER CODES

SY - **DPCA** - **P** - **1**

1
2
3
4

1	▶ Model Name	SY	
2	▶ Control Mode	DPCA	digital proportional controller
3	▶ Type	P	PCB only
4	▶ Output	1	single coil

MODEL SPEC.

Model	SY-DPCA-P-1
Operating Voltage	9 ~ 32VDC
Voltage Tolerance	5%
Input Signal Options	0~5V, 0~10V, 4~20mA, RS485
Output Current	3A max.
Dither Frequency	70 ~ 350Hz
Ramp Up and Down	0.1 ~ 5.0s
Reference Voltage	5V (max. current 5mA)
Communication Interface	RS485
Communication Protocol	Modbus RTU
Operating Conditions	-20 ~ 60°C
Weight	0.06kg

Wiring Instruction

1	VS-	Power-
2	VS+	Power+
3	Out+	Coil+
4	Out-	Coil-
5	Vi+	Input voltage signal
6	Vi- li-	Signal ground
7	li+	Input current signal
8	Enable	Enable *
9	Vref +5V	+5V reference voltage
10	D+	RS485+ (optional)
11	D-	RS485- (optional)

* Default off. Ground this pin to enable controller when PEA function is on.

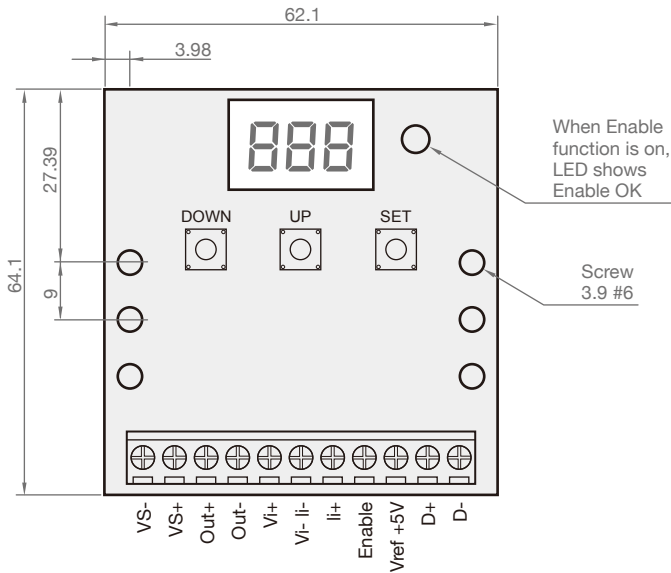

* A USB-RS485 converter (Purchase separately) is necessary to connect PC.

** Using a USB-RS485 converter, you can operate and configure parameters via the PC software provided by our company.

Please mail us to get the PC software : info@steadmachinery.com.tw.



This product has been designed and tested to meet specific standards outlined in the European Electromagnetic Compatibility Directive (EMC)2014/30/EU.

Emission: EN 61000-6-4:2019

Immunity: EN 61000-6-2:2019; EN 61000-4-2:2009, EN 61000-4-3:2020, EN 61000-4-8:2010

Certificate No. NE1105240044

SY-DPCA-C-2



FEATURES

- Dual output with flexible switching
- Standard MODBUS RTU communication
- Advanced PID feedback control
- Independent PWM and dither frequency adjustment

ORDER CODES

SY - **DPCA** - **C** - **2**

1 2 3 4

1	▶ Model Name	SY	
2	▶ Control Mode	DPCA	digital proportional controller
3	▶ Type	C	case with DIN-35 rail clamps
		P	PCB only
4	▶ Output	2	dual coil

MODEL SPEC.

Model	SY-DPCA-C-2
Operating Voltage	9 ~ 32VDC
Voltage Tolerance	5%
Input Signal Options	0~5V, 0~10V, 4~20mA, RS485
Output Current	3A max. for each output
PWM Frequency	70~1000Hz
Dither Frequency	70~500Hz
Ramp Up and Down	0.1 ~ 5.0s
Reference Voltage	5V (max. current 5mA)
Operating Conditions	-20 ~ 60°C
Communication Interface	RS485
Communication Protocol	Modbus RTU
Weight	0.1kg

Wiring Instruction

1	GND	Ground (VS+ / CMD)
2	VS+	Power source
3	CoilA+	Coil A output+
4	CoilA-	Coil A output-
5	CoilB+	Coil B output+
6	CoilB-	Coil B output-
7	CMD1	Command signal 1
8	CMD2	Command signal 2
9	5Vref	5V reference voltage
10	D+	RS485+
11	D-	RS485-

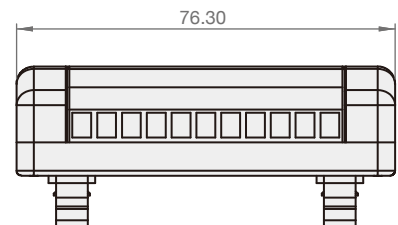
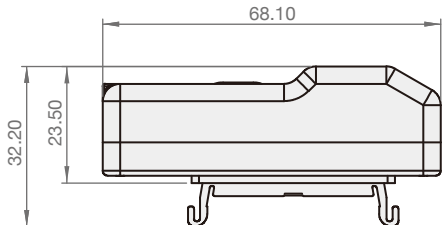
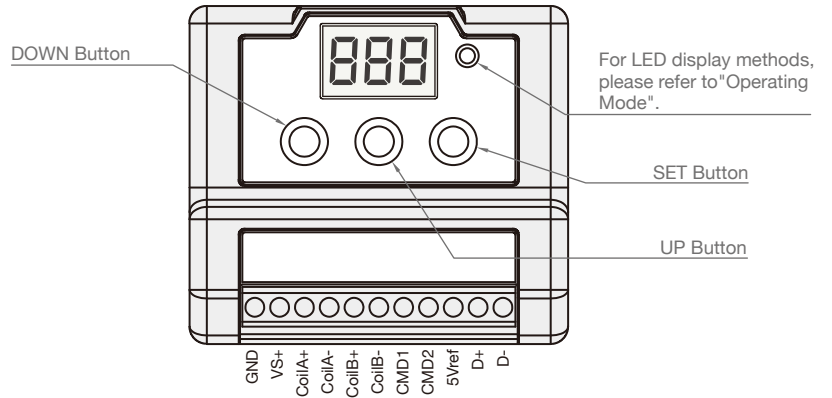
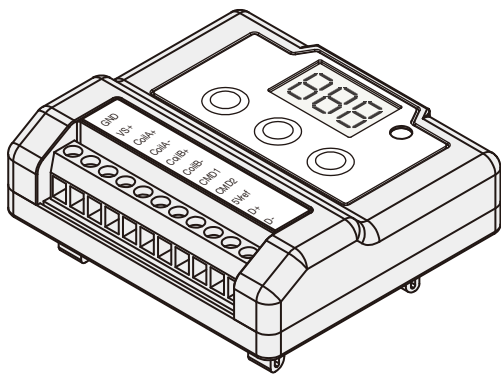

OPERATING MODE

	MODE 1	MODE 2	MODE 3
LED Color	Orange	Green	Red
Description	Single Command vs. Single Output	Dual Indep. Command vs. Dual Indep. Output	Single Command vs. Dual Linked Output

* A USB-RS485 converter (Purchase separately) is necessary to connect PC.

** Using a USB-RS485 converter, you can operate and configure parameters via the PC software provided by our company.

Please mail us to get the PC software : info@steedmachinery.com.tw.



This product has been designed and tested to meet specific standards outlined in the European Electromagnetic Compatibility Directive (EMC)2014/30/EU.

Emission: EN 61000-6-4:2019

Immunity: EN 61000-6-2:2019; EN 61000-4-2:2009, EN 61000-4-3:2020, EN 61000-4-8:2010

Certificate No. NE1105240044

SY-DPCA-D-P9-1



FEATURES

- Direct assembly on the DIN43650 solenoid valve
- Control with digital microprocessor
- Simple setup via physical screen and button
- Short, open circuit protection with error code

ORDER CODES

SY - DPCA - D - P9 - 1

1 2 3 4 5

1	▶ Model Name	SY	
2	▶ Control Mode	DPCA	digital proportional controller
3	▶ Type	D	DIN43650A plug
4	▶ Connection	P9	PG9 cable gland
5	▶ Output	1	single coil

MODEL SPEC.

Model	SY-DPCA-D-P9-1
Operating Voltage	9 ~ 32VDC
Voltage Tolerance	5%
Input Signal Options	0~5V, 0~10V, 4~20mA
Output Current	3A max.
Dither Frequency	70 ~ 350Hz
Ramp Up and Down	0.1 ~ 5.0s
Reference Voltage	5V (max. current 5mA)
Operating Conditions	-20 ~ 60°C
Weight	0.2kg

WIRING PREPARATION

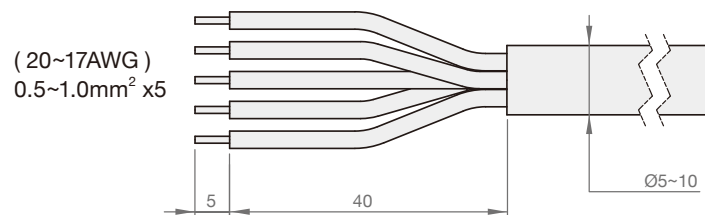

CONNECTIONS

Wiring Instruction

1	VS+	Power+
2	VS-	Power-
3	Vref	+5V reference voltage
4	V & I-	Command ground
5	V & I+	Command

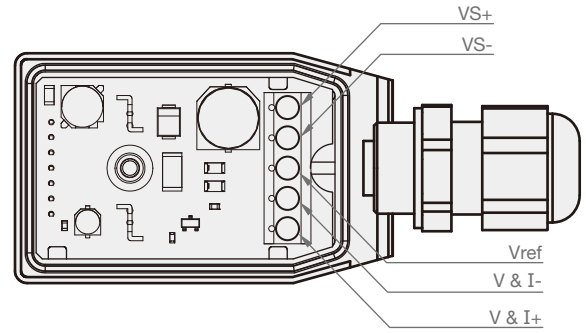

DIMENSIONS

(UNIT : mm)

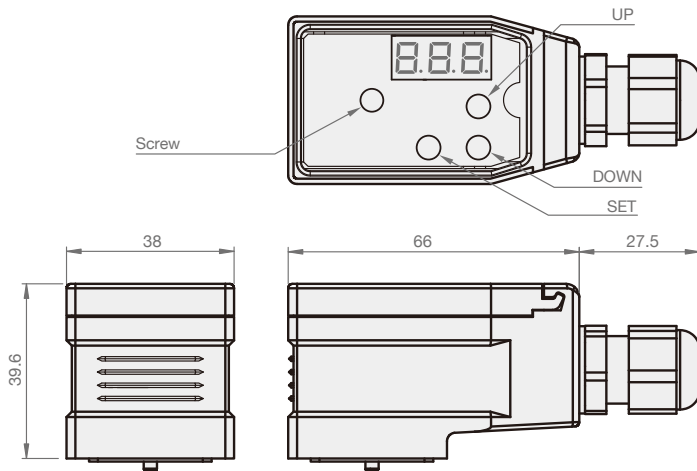

ASSEMBLY

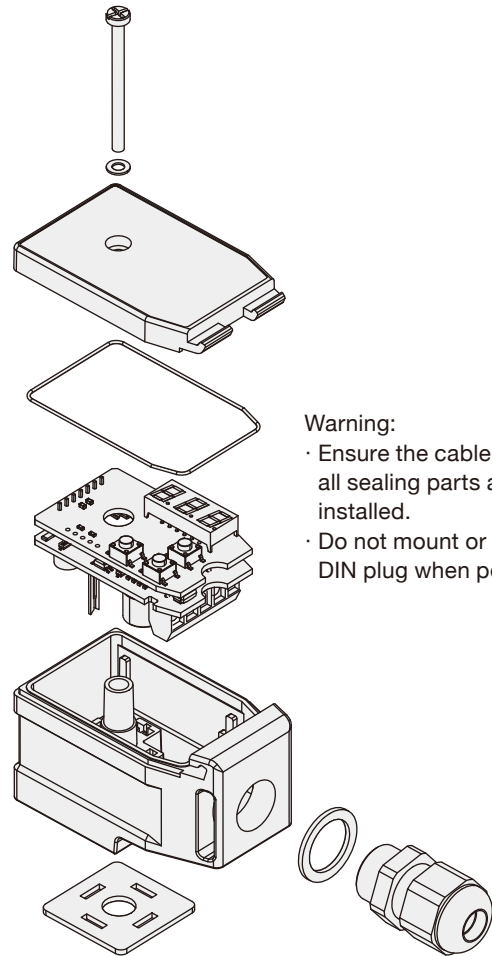

Warning:

- Ensure the cable gland and all sealing parts are properly installed.
- Do not mount or dismount the DIN plug when power is on.



This product has been designed and tested to meet specific standards outlined in the European Electromagnetic Compatibility Directive (EMC)2014/30/EU.

Emission: EN 61000-6-4:2019

Immunity: EN 61000-6-2:2019; EN 61000-4-2:2009, EN 61000-4-3:2020, EN 61000-4-8:2010

Certificate No. NE1105240044

FLA

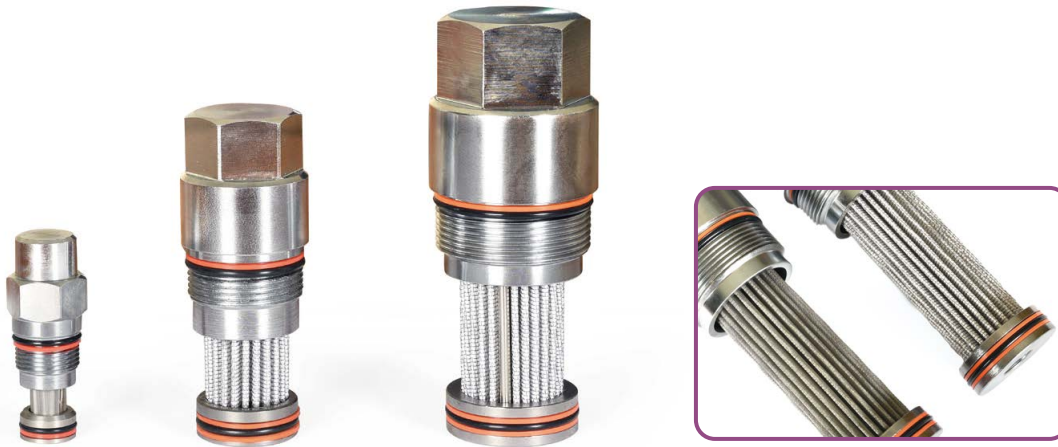

SYMBOLS

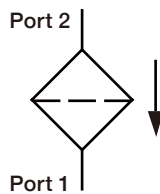

ORDER CODES

FL 2 A - T13A - X D N

1 2 1 3 4 5 6

1	▶ Model Name	FLA	
2	▶ Valve Size	2, 3, 6, 8	
3	▶ Cavity	T13A, T5A, T16A, T18A	
4	▶ Control Manner	X	unadjustable
5	▶ Filter Rating (FL2A, FL3A)	D	40um (surface type)
	▶ Filter Rating (FL6A, FL8A)	D	40um (surface type)
		A	3um (depth type)
		B	10um (depth type)
		C	25um (depth type)
6	▶ Material of Seal	N	buna-N
		V	viton

MODEL SPEC.

Model	Cavity	Capacity	Max. Pressure	Installation Torque (Nm)	Operating Temperature	Weight (kg)
FL2A	T13A	37.9 l/min / 10 gpm	345 bar / 5000 psi	40/50	-35 ~ 100°C (-31 ~ 212°F)	0.09
FL3A	T5A	75.7 l/min / 20 gpm		60/70		0.19
FL6A	T16A	151.4 l/min / 40 gpm		200/215		0.315
FL8A	T18A	302.8 l/min / 80 gpm		465/500		0.71

PERFORMANCE CURVES

► FL2A

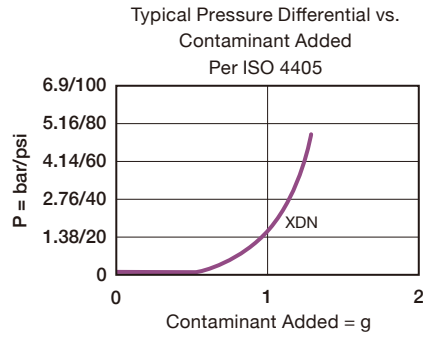
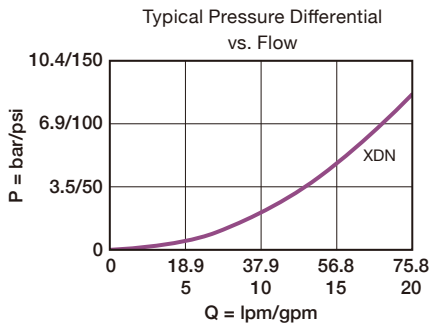

► FL3A

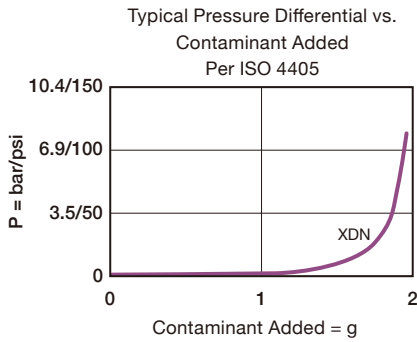

► FL6A

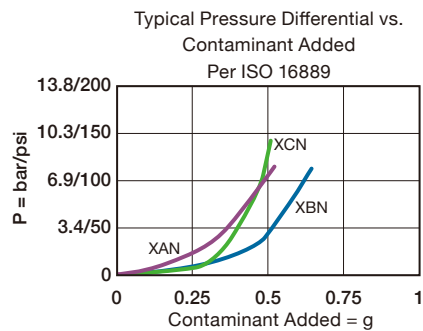
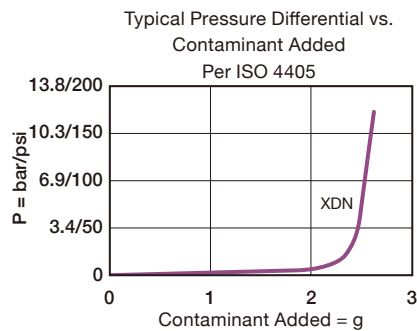
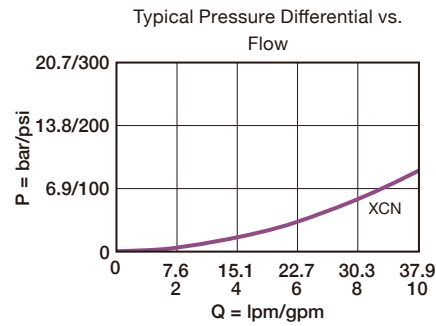
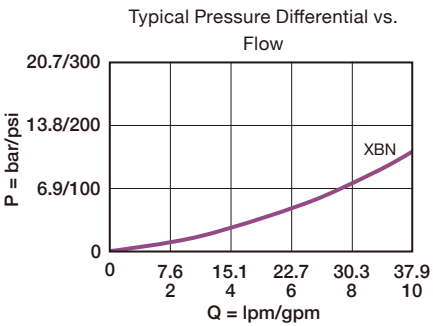
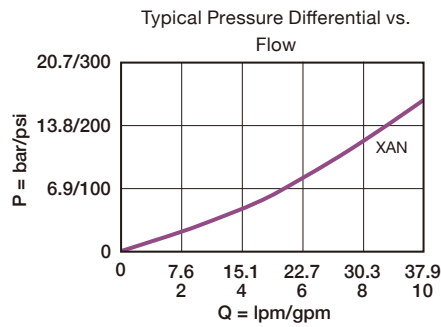
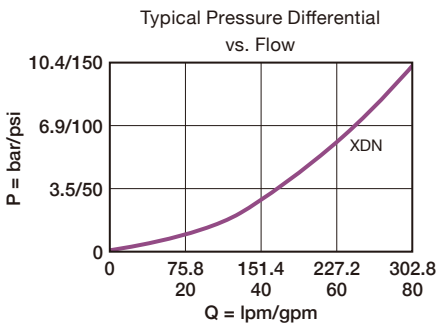

► FL8A

Typical Pressure Differential vs. Flow

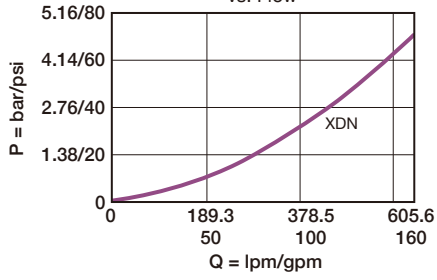

Typical Pressure Differential vs. Flow

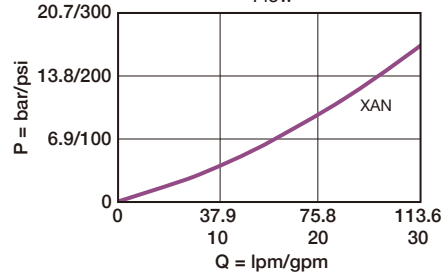

Typical Pressure Differential vs. Flow

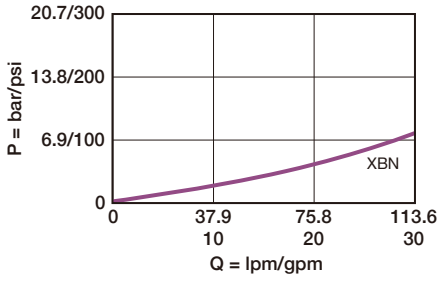

Typical Pressure Differential vs. Flow

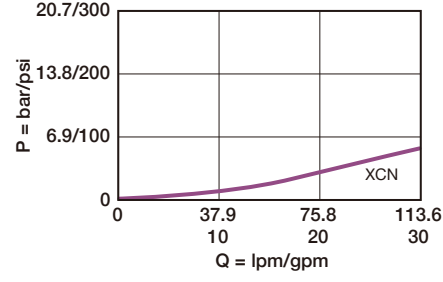

Typical Pressure Differential vs. Contaminant Added Per ISO 4405

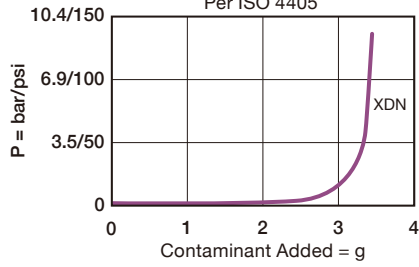

Typical Pressure Differential vs. Contaminant Added Per ISO 16889

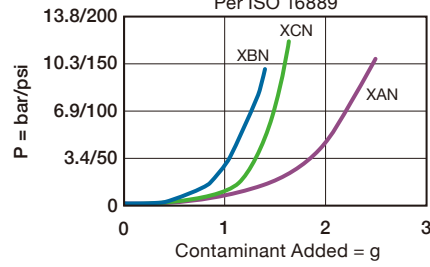

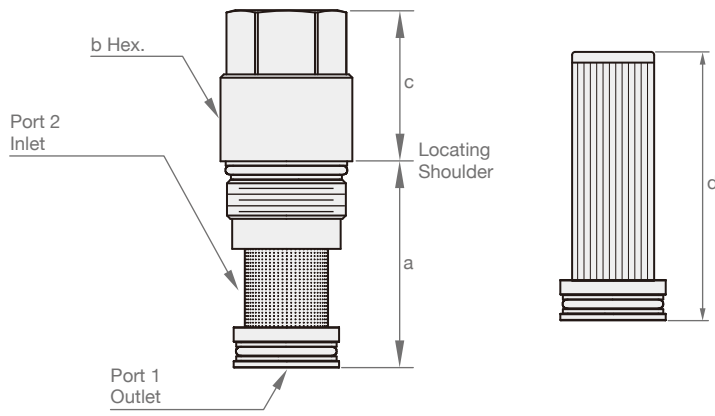

Model	a	b	c	d
FL2A	40.0	22.2	30.7	59.5
FL3A	41.7	28.6	33.3	66.0
FL6A	62.2	31.8	41.4	97.5
FL8A	79.5	41.3	54.1	126

MH



SYMBOLS

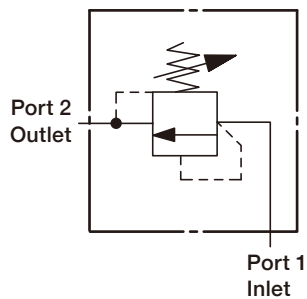

ORDER CODES

MH - **082** - **L** **A** **N**

1 2 3 4 5

1	▶ Model Name	MH	
2	▶ Valve Size & Cavity	082, 092, 102, 122	
3	▶ Control Manner	L	standard screw adjustment
		K	hand knob with lock knob
		C	tamper resistant cover
4	▶ Adjustable Range	A	7 ~ 210 bar
		B	3.5 ~ 105 bar
		C	90 ~ 350 bar
5	▶ Material of Seal	N	buna-N
		V	viton
		E	EPDM
		H	HNBR
		U	polyurethane

MODEL SPEC.

Model	Cavity	Capacity (l/min)	Max. Pressure (bar)	Installation Torque (Nm)	Operating Temperature	Weight (kg)
MH-082	T082	25	350	40/50	-35 ~ 100°C (-31 ~ 212°F)	0.15
MH-092	T092	45	350	40/50		0.25
MH-102	T102	55	350	40/50		0.20
MH-122	T122	85	280	45/50		0.32

PERFORMANCE CURVES

► Typical Pressure Rise

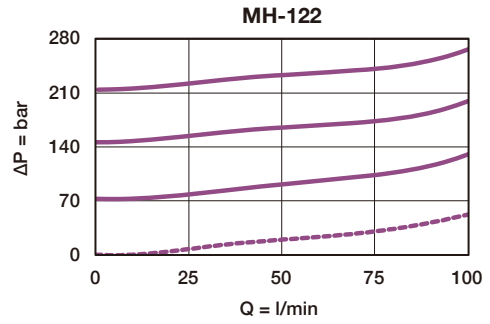
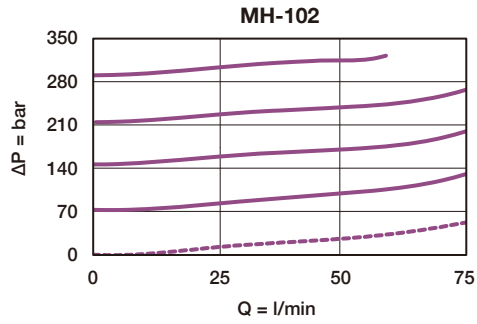
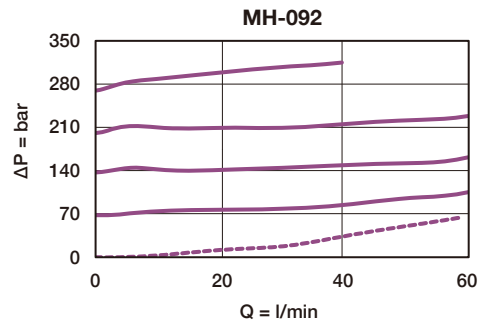
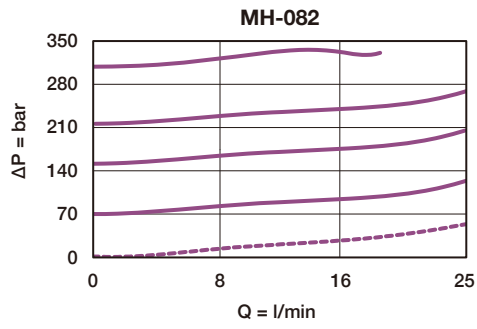

DIMENSION

(UNIT : mm)

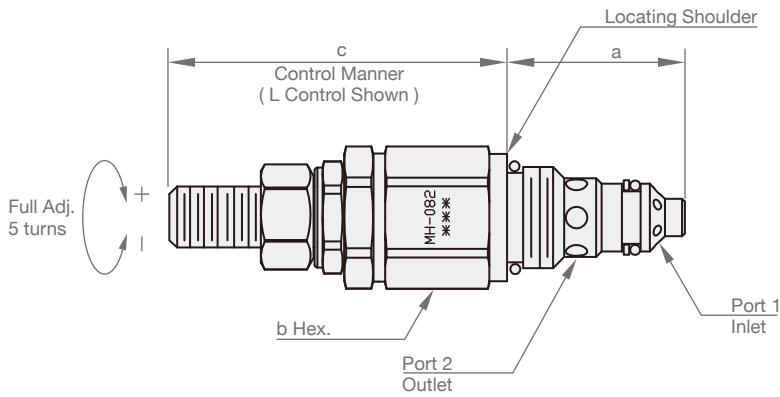

Model	a	b	c		
			L	K	C
MH-082	34	24	60	66	48
MH-092	54	26	58	93	36
MH-102	38.8	25.4	58	64	36
MH-122	59	31.8	61	-	67

CN



SYMBOLS

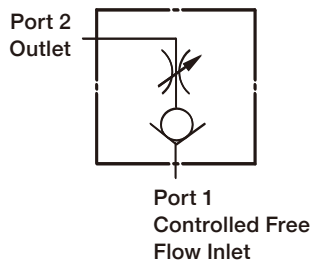

ORDER CODES

CN - **082** - **L** **A** **N**

1 2 3 4 5

1	▶ Model Name	CN	
2	▶ Cavity & Max. Orifice	082, 102, 122, 162	
3	▶ Control Manner	L	standard screw adjustment
		K	hand knob with lock knob
4	▶ Cracking Pressure	A	0.3 bar
		C	2.0 bar
		E	5.0 bar
5	▶ Material of Seal	N	buna-N
		V	viton
		E	EPDM
		H	HNBR
		U	polyurethane

MODEL SPEC.

Model	Cavity	Capacity (l/min)	Max. Pressure (bar)	Installation Torque (Nm)	Operating Temperature	Weight (kg)
CN-082	T082	30	300	40/50	-35 ~ 100°C (-31 ~ 212°F)	0.11
CN-102	T102	50	300	40/50		0.14
CN-122	T122	80	300	40/50		0.26
CN-162	T162	150	300	40/50		0.39

PERFORMANCE CURVES

► Typical Pressure Drop

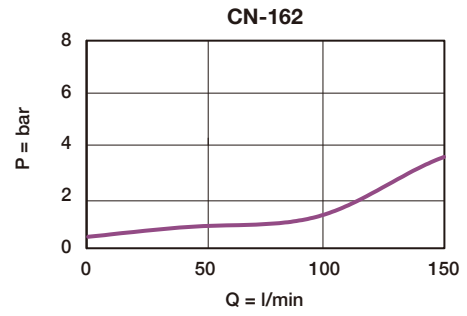
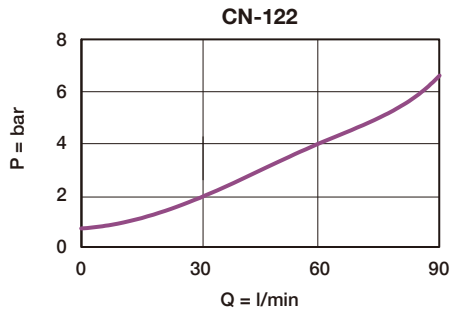
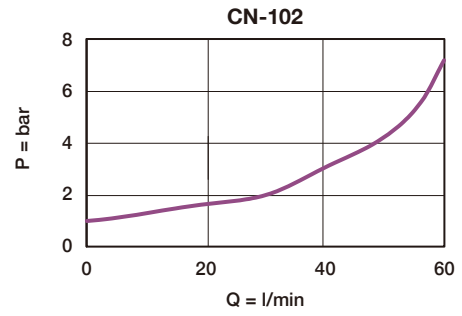
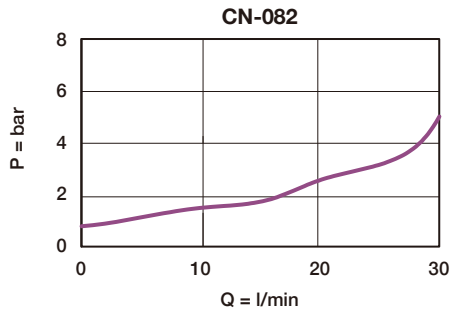

DIMENSION

(UNIT : mm)

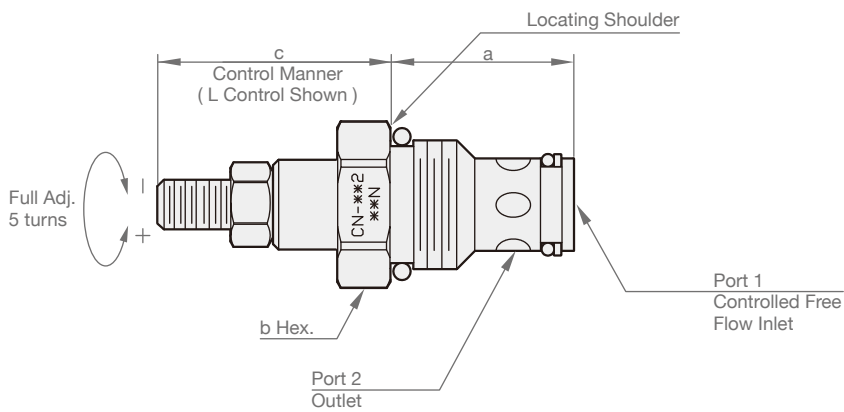

Model	a	b	c	
			L	K
CN-082	27.7	22.4	48	53
CN-102	31.8	25.4	51	56
CN-122	46.0	31.8	53	58
CN-162	44.5	38.1	59	64

NV



SYMBOLS

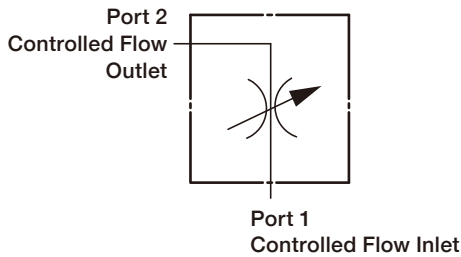

ORDER CODES

NV - **082** - **L** **A** **N**

1 2 3 4

1	▶ Model Name	NV	
2	▶ Cavity & Max. Orifice	082	T082, 6.5mm
		102	T102, 8.5mm
		122	T122, 12.5mm
		162	T162, 16mm
3	▶ Control Manner	L	standard screw adjustment
		K	hand knob with lock knob
4	▶ Material of Seal	N	buna-N
		V	viton
		E	EPDM
		H	HNBR
		U	polyurethane

MODEL SPEC.

Model	Cavity	Capacity (l/min)	Max. Pressure (bar)	Installation Torque (Nm)	Operating Temperature	Weight (kg)
NV-082	T082	30	300	40/50	-35 ~ 100°C (-31 ~ 212°F)	0.11
NV-102	T102	50	300	40/50		0.14
NV-122	T122	80	300	40/50		0.26
NV-162	T162	150	300	40/50		0.39

PERFORMANCE CURVES

Typical Pressure Drop

— Fully Open, Port1 ~ Port2

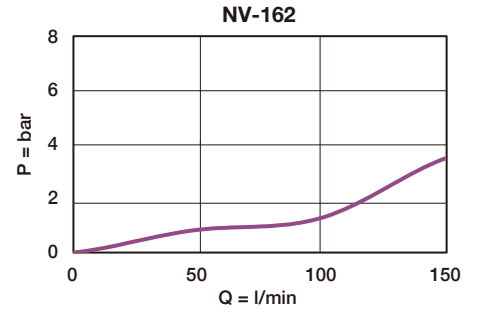
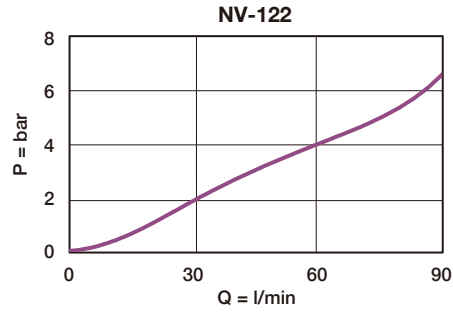
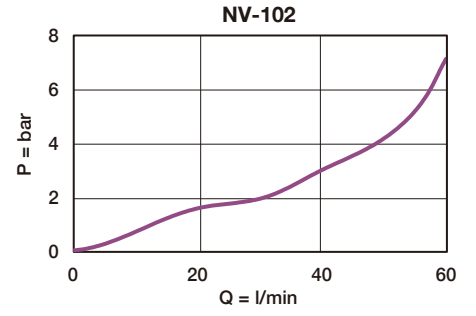
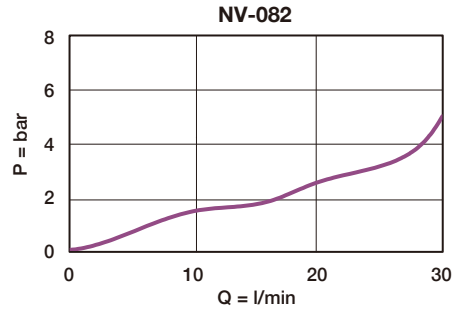

DIMENSION

(UNIT : mm)

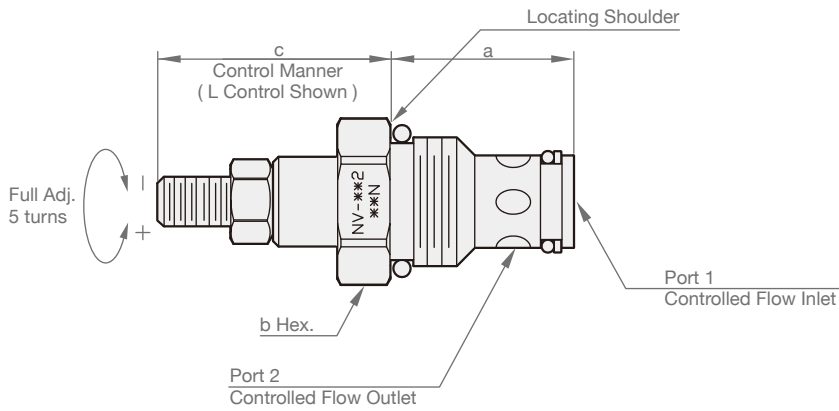

Model	a	b	c	
			L	K
NC-082	27.7	22.4	48	53
NC-102	31.8	25.4	51	56
NC-122	46.0	31.8	53	58
NC-162	44.5	38.1	59	64

NC



SYMBOLS

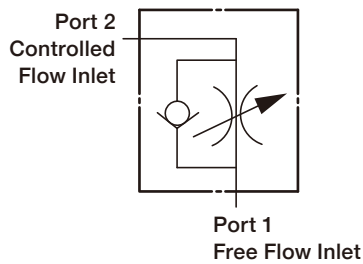

ORDER CODES

NC - **082** - **L** **C** **N**

1 2 3 4 5

1	Model Name	NC	
2	Cavity & Max. Orifice	082	T082, 5.9mm
		102	T102, 8mm
		122	T122, 11mm
		162	T162, 13mm
3	Control Manner	L	standard screw adjustment
		K	hand knob with lock knob
4	Cracking Pressure	C	2.0 bar
5	Material of Seal	N	buna-N
		V	viton
		E	EPDM
		H	HNBR
		U	polyurethane

MODEL SPEC.

Model	Cavity	Capacity (l/min)	Max. Pressure (bar)	Installation Torque (Nm)	Operating Temperature	Weight (kg)
NC-082	T082	30	300	40/50	-35 ~ 100°C (-31 ~ 212°F)	0.11
NC-102	T102	50	300	40/50		0.14
NC-122	T122	80	300	40/50		0.26
NC-162	T162	150	300	40/50		0.39

PERFORMANCE CURVES

Typical Pressure Drop

- Free Flow, Port1 ~ Port2
- Fully Open, Port2 ~ Port1

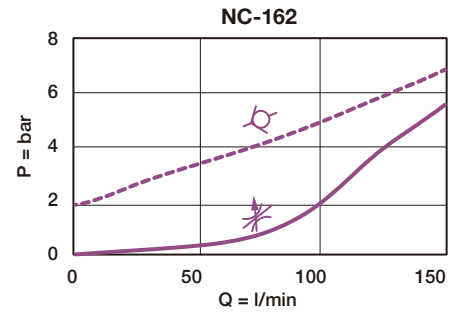
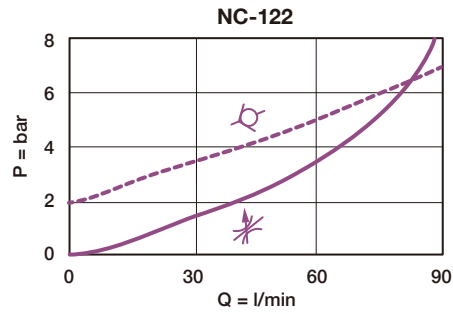
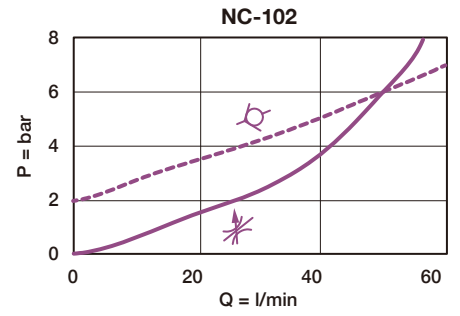
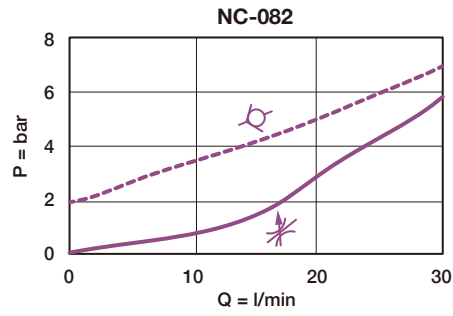

DIMENSION

(UNIT : mm)

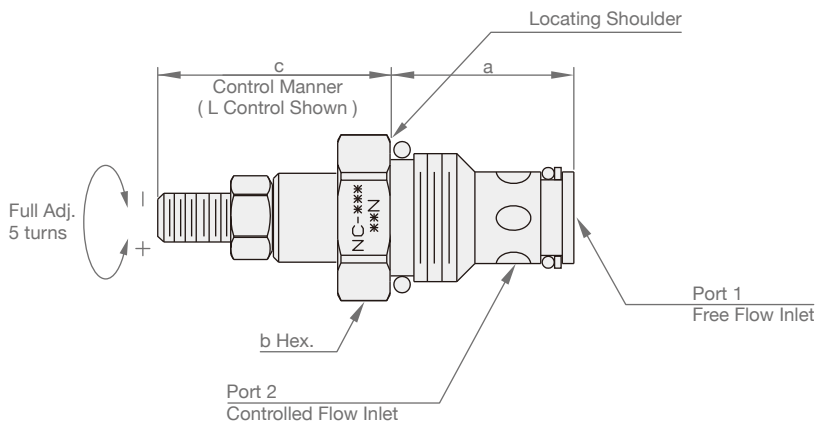

Model	a	b	c	
			L	K
NC-082	27.7	22.4	48	53
NC-102	31.8	25.4	51	56
NC-122	46.0	31.8	53	58
NC-162	44.5	38.1	59	64

CP



SYMBOLS

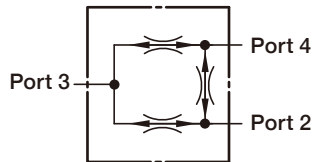

Flow Ratio:
Port 2 : Port 4 = 1:1

ORDER CODES

CP - **104** - **2** - **X** **C** **N**

1 2 3 4 5 6

1	Model Name	CP	
2	Valve Size & Cavity	104, 124, 164	
3	Type	none	standard
		2	anti-stall
4	Control Manner	X	unadjustable
5	Capacity (l/min)	A	CP-104: 7.6, CP-124: 38, CP-164: 91
		B	CP-104: 23, CP-124: 53, CP-164: 114
		C	CP-104: 45, CP-124: 90, CP-164: 150
		N	buna-N
6	Material of Seal	V	viton
		E	EPDM
		H	HNBR
		U	polyurethane

MODEL SPEC.

Model	Cavity	Capacity (l/min)	Max. Pressure (bar)	Installation Torque (Nm)	Operating Temperature	Weight (kg)
CP-104	T104	45	210	35/45	-35 ~ 100°C (-31 ~ 212°F)	0.11
CP-124	T124	90	210	45/55		0.23
CP-164	T164	150	210	60/70		0.37

PERFORMANCE CURVES

► Typical Pressure Drop

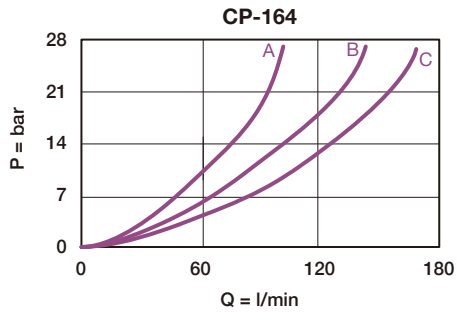
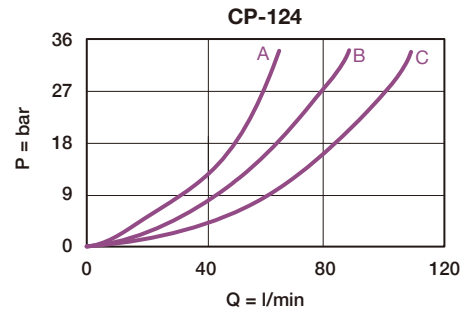
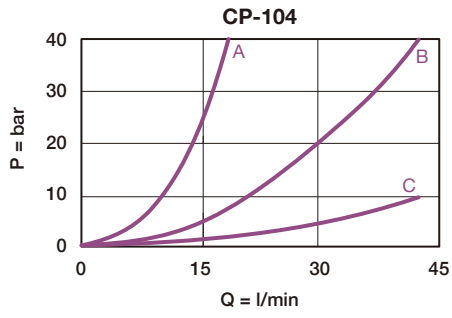

DIMENSION

(UNIT : mm)

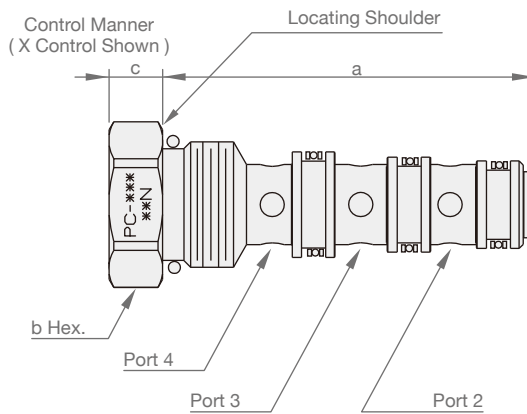

Model	a	b	c
			X
CP-104	64.8	25.4	7.9
CP-124	85.1	31.8	9.5
CP-164	105.0	38.1	12.7

CV



SYMBOLS



ORDER CODES

CV - **082** - **X** **A** **N**

1 2 3 4 5

1	▶ Model Name	CV	
2	▶ Valve Size & Cavity	082, 102, 122, 162	
3	▶ Control Manner	X	unadjustable
4	▶ Cracking Pressure	A	0.3 bar
		C	2.0 bar
		E	5.0 bar
5	▶ Material of Seal	N	buna-N
		V	viton
		E	EPDM
		H	HNBR
		U	polyurethane

MODEL SPEC.

Model	Cavity	Capacity (l/min)	Max. Pressure (bar)	Installation Torque (Nm)	Operating Temperature	Weight (kg)
CV-082	T082	30	300	40/50	-35 ~ 100°C (-31 ~ 212°F)	0.06
CV-102	T102	50	300	40/50		0.09
CV-122	T122	80	300	40/50		0.15
CV-162	T162	150	300	40/50		0.27

PERFORMANCE CURVES

► Typical Pressure Drop

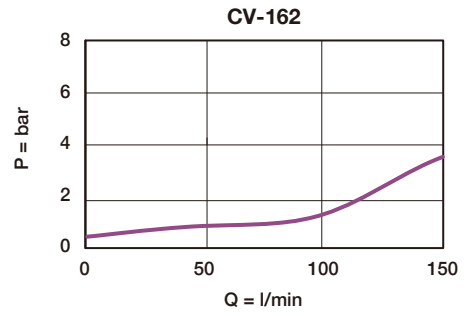
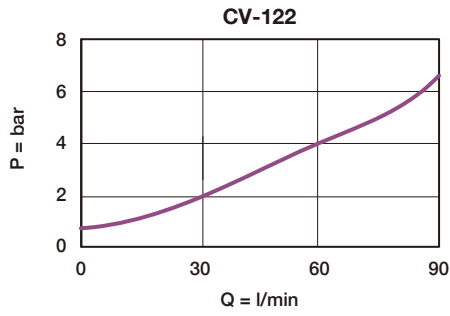
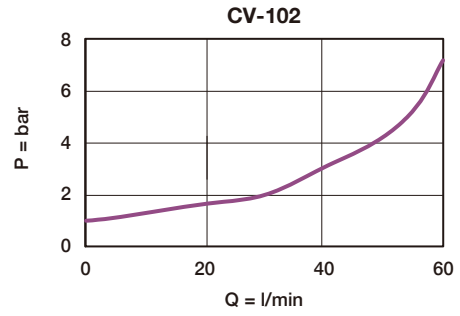
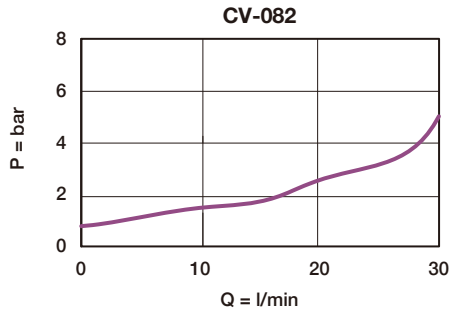

DIMENSION

(UNIT : mm)

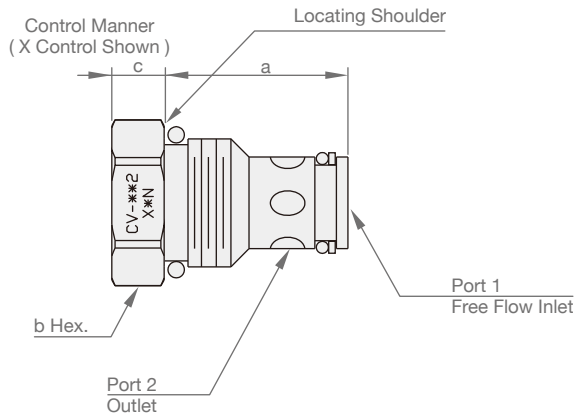

Model	a	b	c
			X
CV-082	27.7	22.4	7.9
CV-102	31.8	25.4	7.9
CV-122	46.0	31.8	9.5
CV-162	44.5	38.1	14.0

LS



SYMBOLS

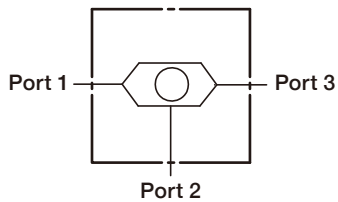

ORDER CODES

LS - **083** - **X** X **N**

① ② ③ ④

① ▶ Model Name	LS	
② ▶ Valve Size & Cavity	083, 103	
③ ▶ Control Manner	X	unadjustable
④ ▶ Material of Seal	N	buna-N
	V	viton
	E	EPDM
	H	HNBR
	U	polyurethane

MODEL SPEC.

Model	Cavity	Capacity (l/min)	Max. Pressure (bar)	Installation Torque (Nm)	Operating Temperature	Weight (kg)
LS-083	T083	15	240	30/40	-35 ~ 100°C (-31 ~ 212°F)	0.06
LS-103	T103	30	240	40/50		0.10

PERFORMANCE CURVES

► Typical Pressure Drop

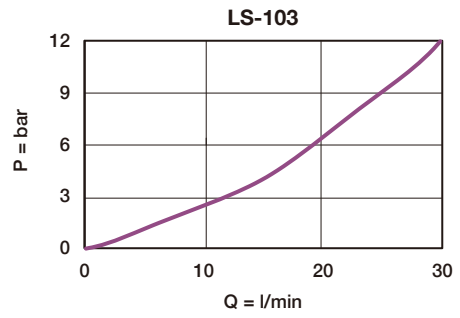
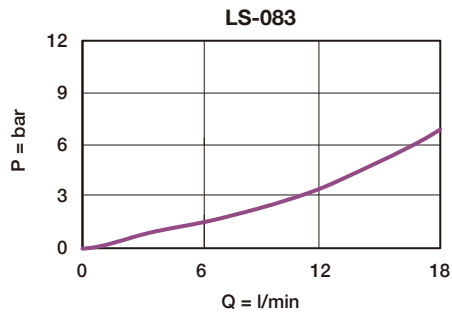

DIMENSION

(UNIT : mm)

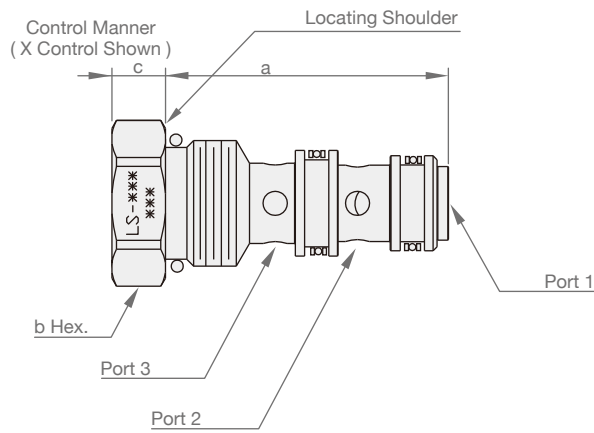

Model	a	b	c
			X
LS-083	42.2	22.4	8
LS-103	46.0	25.4	8

HS, JS, LS, PS-2A



SYMBOLS

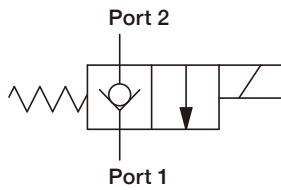

ORDER CODES

HS - **2A** - **16** - **A1**

1 2 3 4

1 ▶ Cavity	HS	T082
	JS	T102
	LS	T122
	PS	T162
2 ▶ Type of Valve	2A	
	16	
3 ▶ Tube Diameter	16	
	16	
4 ▶ Power Source	A1	RAC110V
	A2	RAC220V
	D1	DC12V
	D2	DC24V

MODEL SPEC.

Model	Cavity	Tube Diameter	Capacity (l/min)	Max. Pressure (bar)	Installation Torque (Nm)	Weight (kg)
HS-2A	T082	16	28	250	39/51	0.41
JS-2A	T102	16	50	250	39/51	0.43
LS-2A	T122	16	100	250	39/51	0.53
PS-2A	T162	16	150	250	39/51	0.62

PERFORMANCE CURVES

Typical Pressure Drop

- - - de-energized,
Port 1 → Port 2
- energized,
Port 2 → Port 1

* 32cSt / 150 ssu oil at 40°C

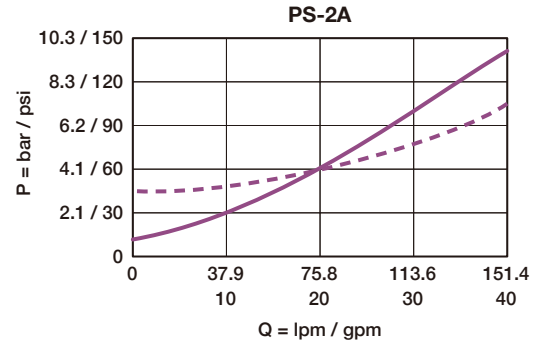
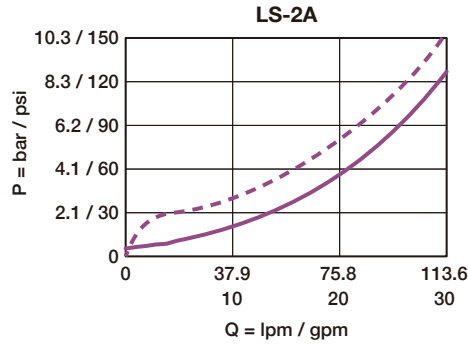
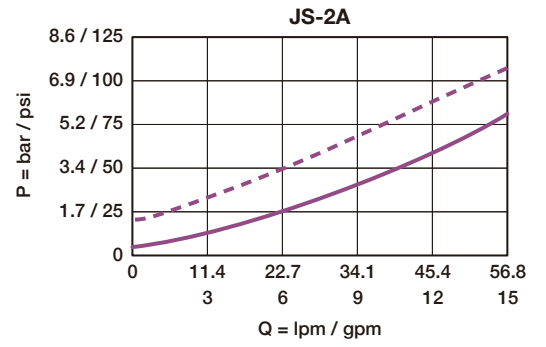
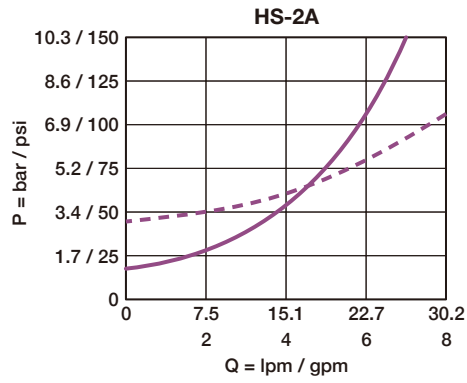

DIMENSION

(UNIT : mm)

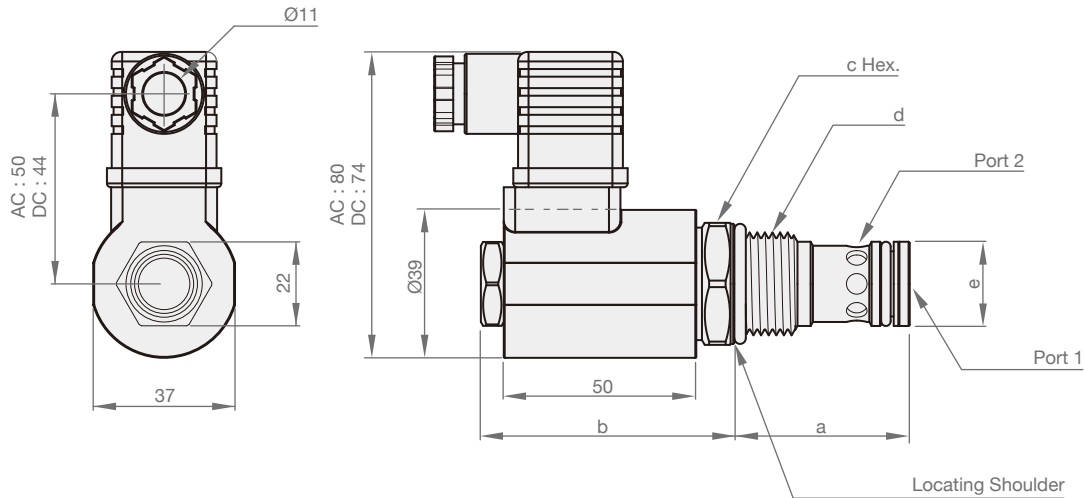

Model	a	b	c	d	e
HS-2A	28	64	22	3/4"-16UNF	12.7
JS-2A	32	64	25.4	7/8"-14UNF	15.8
LS-2A	45	64	32	1 1/16"-12UNF	22.2
PS-2A	45	65	38	1 5/16"-12UNF	28.6

HS, JS, LS, PS-2B



SYMBOLS

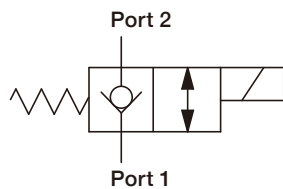

ORDER CODES

HS - **2B** - **16** - **A2**

① ② ③ ④

① ▶ Cavity	HS	T082
	JS	T102
	LS	T122
	PS	T162
② ▶ Type of Valve	2B	
③ ▶ Tube Diameter	16	
④ ▶ Power Source	A1	RAC110V
	A2	RAC220V
	D1	DC12V
	D2	DC24V

MODEL SPEC.

Model	Cavity	Tube Diameter	Capacity (l/min)	Max. Pressure (bar)	Installation Torque (Nm)	Weight (kg)
HS-2B	T082	16	28	250	39/51	0.41
JS-2B	T102	16	50	250	39/51	0.43
LS-2B	T122	16	100	250	39/51	0.53
PS-2B	T162	16	150	250	39/51	0.62

PERFORMANCE CURVES

Typical Pressure Drop

HS-2B, PS-2B

- - - de-energized, Port 1 → Port 2
- energized, Port 2 → Port 1

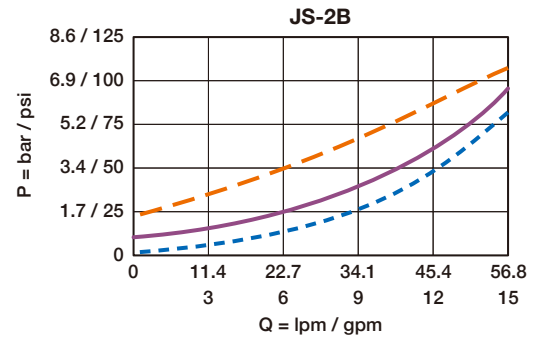
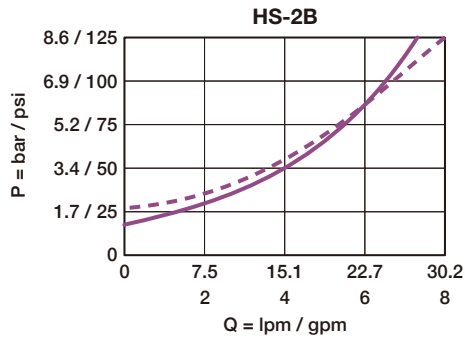

JS-2B, LS-2B

- - - de-energized, Port 1 → Port 2
- energized, Port 2 → Port 1
- - - energized, Port 1 → Port 2

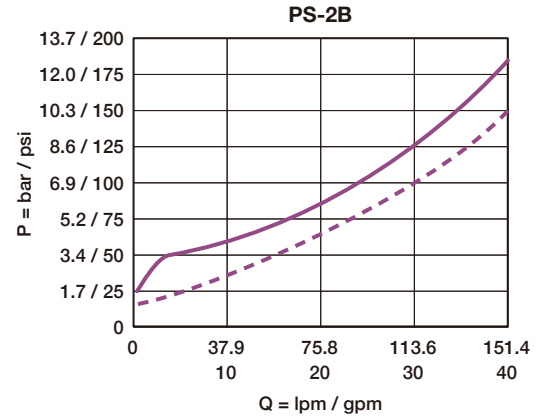
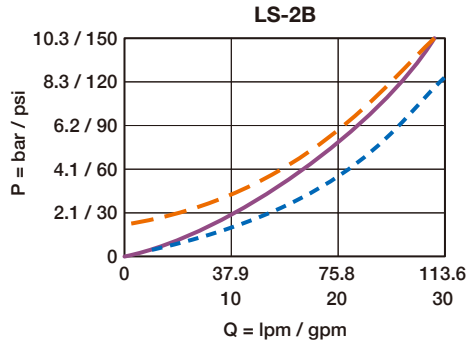

* 32cSt / 150 ssu oil at 40°C

DIMENSION

(UNIT : mm)

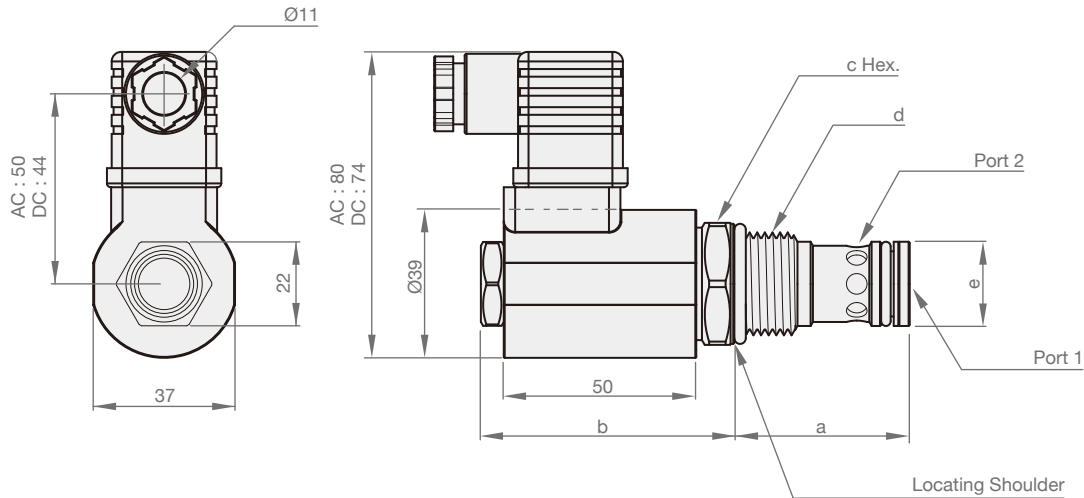

Model	a	b	c	d	e
HS-2B	28	64	22	3/4"-16UNF	12.7
JS-2B	32	64	25.4	7/8"-14UNF	15.8
LS-2B	45	64	32	1 1/16"-12UNF	22.2
PS-2B	45	65	38	1 5/16"-12UNF	28.6

HS, JS, LS, PS-2C



SYMBOLS

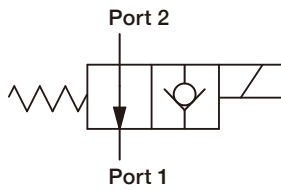

ORDER CODES

JS - **2C** - **16** - **A1**

① ② ③ ④

① ▶ Cavity	HS	T082
	JS	T102
	LS	T122
	PS	T162
② ▶ Type of Valve	2C	
③ ▶ Tube Diameter	16	
④ ▶ Power Source	A1	RAC110V
	A2	RAC220V
	D1	DC12V
	D2	DC24V

MODEL SPEC.

Model	Cavity	Tube Diameter	Capacity (l/min)	Max. Pressure (bar)	Installation Torque (Nm)	Weight (kg)
HS-2C	T082	16	28	250	39/51	0.41
JS-2C	T102	16	50	250	39/51	0.43
LS-2C	T122	16	100	250	39/51	0.56
PS-2C	T162	16	150	250	39/51	0.67

PERFORMANCE CURVES

Typical Pressure Drop

- - - energized,
Port 1 → Port 2
- de-energized,
Port 2 → Port 1

* 32cSt / 150 ssu oil at 40°C

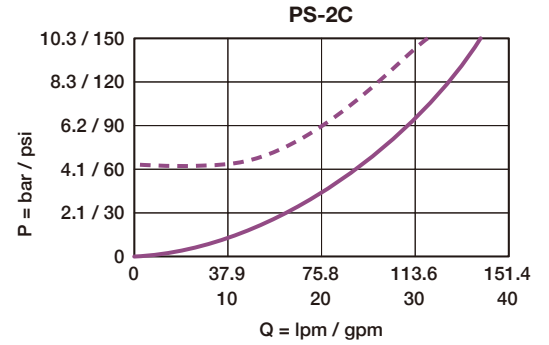
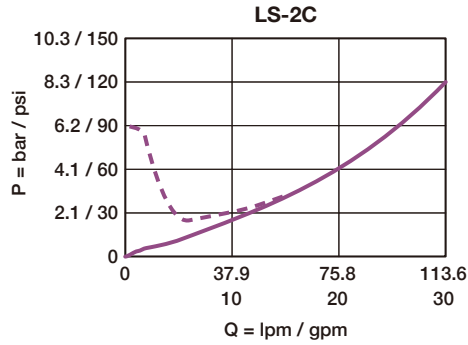
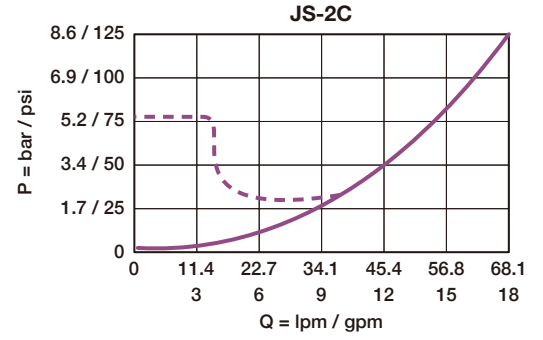
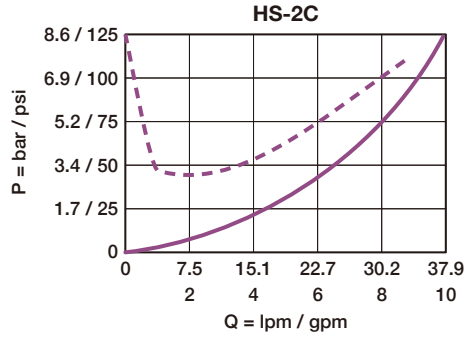

DIMENSION

(UNIT : mm)

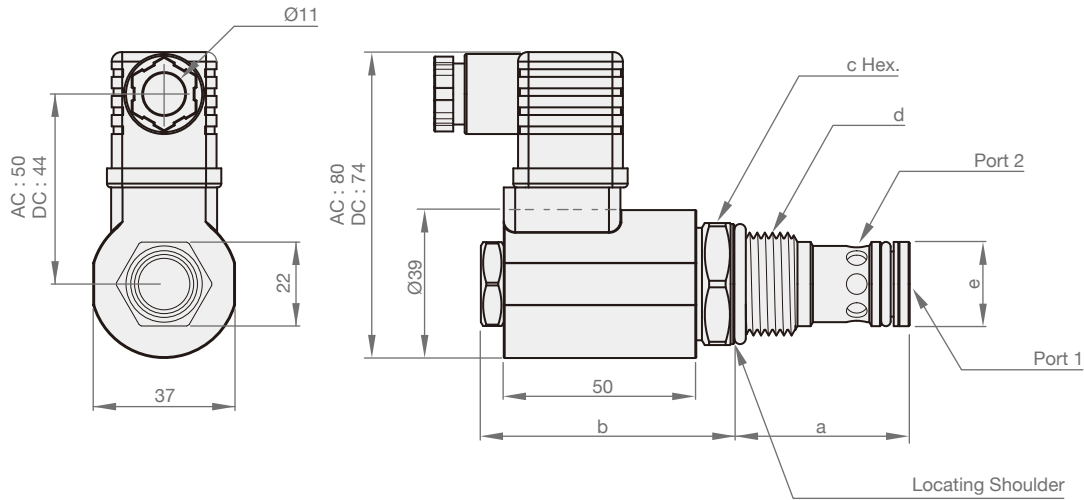

Model	a	b	c	d	e
HS-2C	28	64	22	3/4"-16UNF	12.7
JS-2C	32	64	25.4	7/8"-14UNF	15.8
LS-2C	45	64	32	1 1/16"-12UNF	22.2
PS-2C	45	65	38	1 5/16"-12UNF	28.6

HS, JS, LS, PS-2D



SYMBOLS

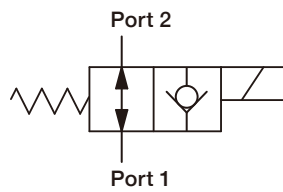

ORDER CODES

JS - **2D** - **16** - **A2**

① ② ③ ④

① ▶ Cavity	HS	T082
	JS	T102
	LS	T122
	PS	T162
② ▶ Type of Valve	2D	
	16	
③ ▶ Tube Diameter	16	
	16	
④ ▶ Power Source	A1	RAC110V
	A2	RAC220V
	D1	DC12V
	D2	DC24V

MODEL SPEC.

Model	Cavity	Tube Diameter	Capacity (l/min)	Max. Pressure (bar)	Installation Torque (Nm)	Weight (kg)
HS-2D	T082	16	28	250	39/51	0.41
JS-2D	T102	16	50	250	39/51	0.46
LS-2D	T122	16	100	250	39/51	0.56
PS-2D	T162	16	150	250	39/51	0.67

PERFORMANCE CURVES

Typical Pressure Drop

- - - energized, Port 1 → Port 2
- de-energized, Port 2 → Port 1

* 32cSt / 150 ssu oil at 40°C

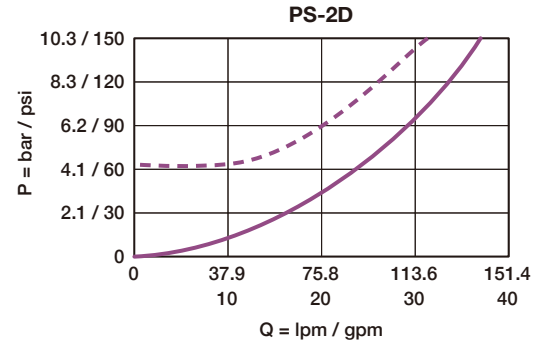
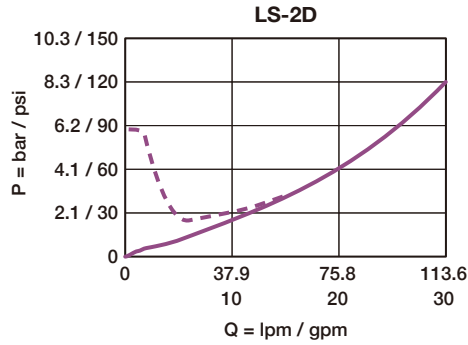
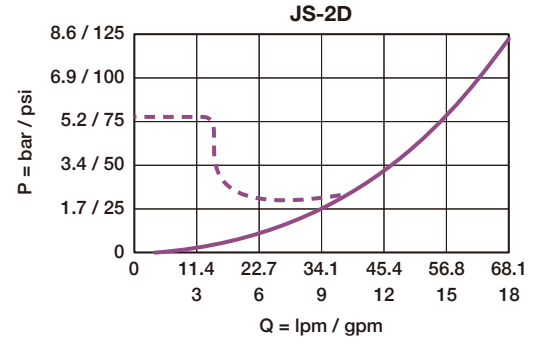
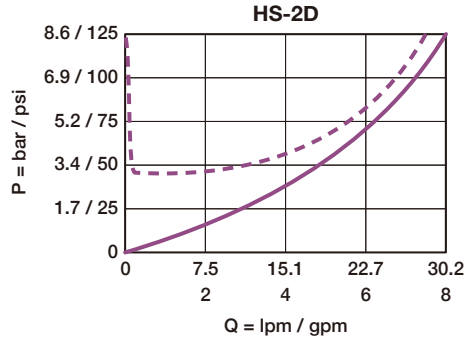

DIMENSION

(UNIT : mm)

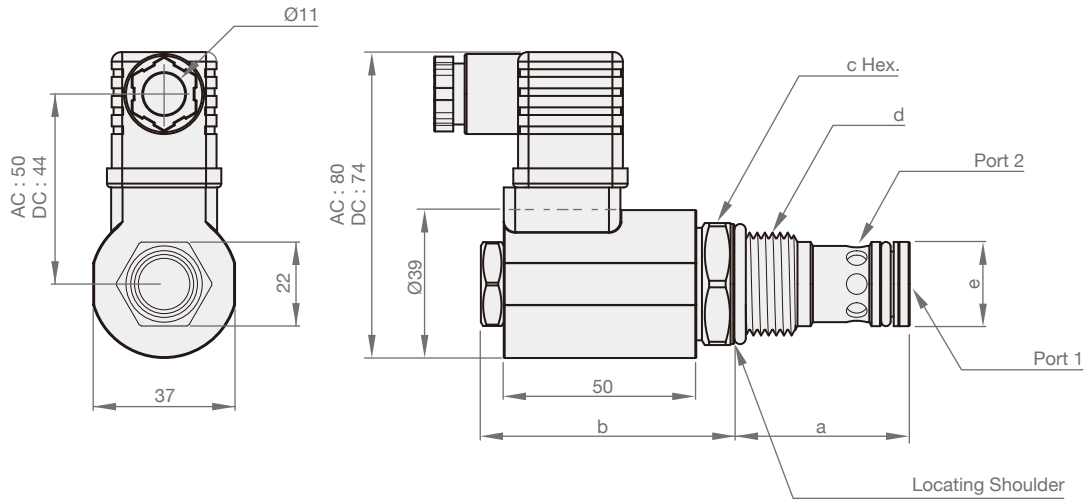

Model	a	b	c	d	e
HS-2D	28	64	22	3/4"-16UNF	12.7
JS-2D	32	64	25.4	7/8"-14UNF	15.8
LS-2D	45	64	32	1 1/16"-12UNF	22.2
PS-2D	45	65	38	1 5/16"-12UNF	28.6

HS, JS, LS, PS-2I



SYMBOLS

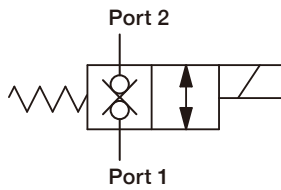

ORDER CODES

PS - **2I** - **19** - **D1**

① ② ③ ④

① ▶ Cavity	HS	T082
	JS	T102
	LS	T122
	PS	T162
② ▶ Type of Valve	2I	
③ ▶ Tube Diameter	16, 19	
④ ▶ Power Source	A1	RAC110V
	A2	RAC220V
	D1	DC12V
	D2	DC24V

MODEL SPEC.

Model	Cavity	Tube Diameter	Capacity (l/min)	Max. Pressure (bar)	Installation Torque (Nm)	Weight (kg)
HS-2I	T082	16	28	250	39/51	0.41
JS-2I	T102	16	50	250	39/51	0.45
LS-2I	T122	16	100	250	39/51	0.56
PS-2I	T162	19	150	250	39/51	0.67

PERFORMANCE CURVES

Typical Pressure Drop

HS-2I

— energized,
Port 2 ↔ Port 1

JS-2I

— energized,
Port 1 → Port 2
- - - energized,
Port 2 → Port 1

LS-2I, PS-2I

— energized,
Port 1 → Port 2
- - - de-energized,
Port 2 → Port 1

* 32cSt / 150 ssu oil at 40°C

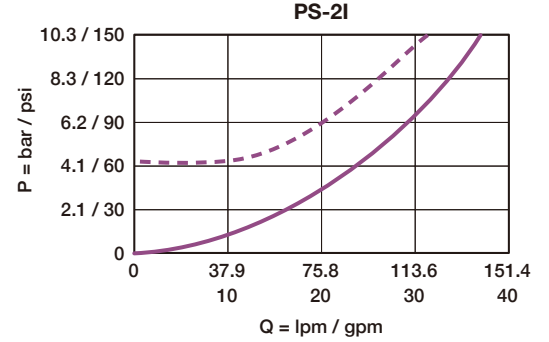
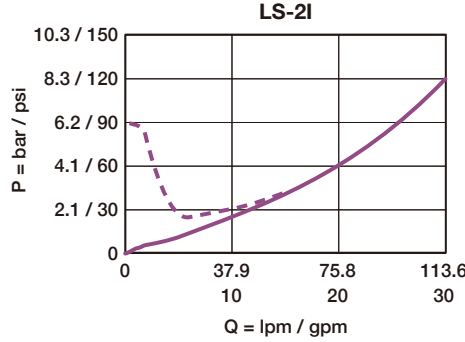
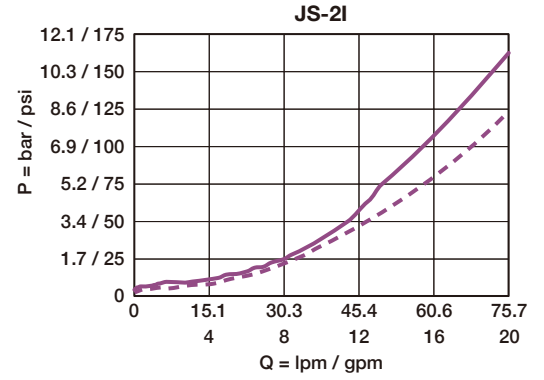
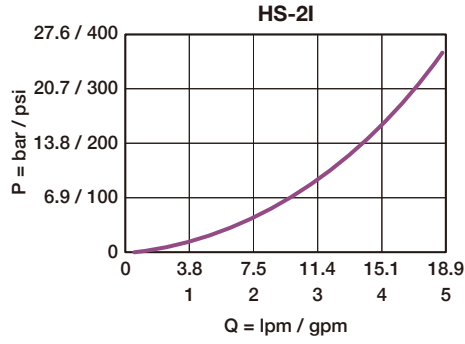

DIMENSION

(UNIT : mm)

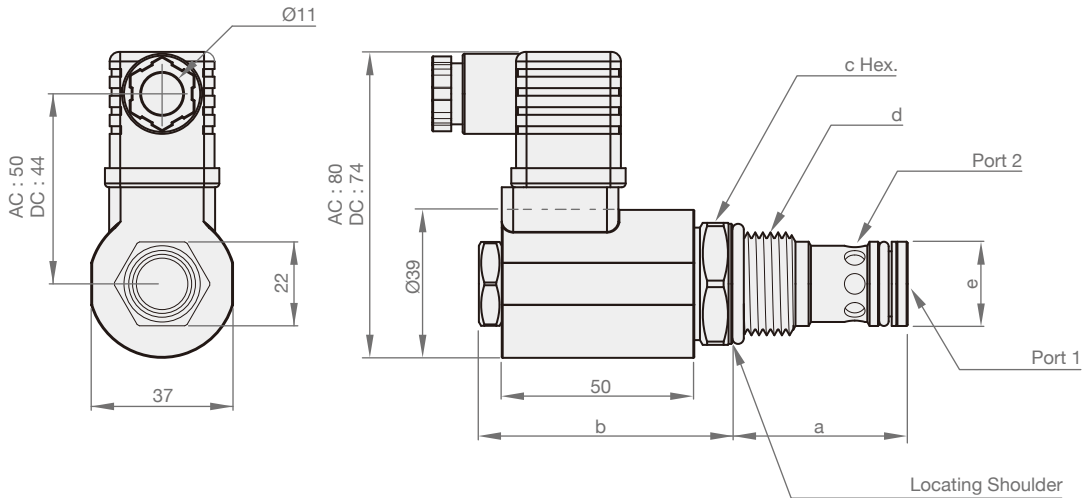

Model	a	b	c	d	e
HS-2I	28	64	22	3/4"-16UNF	12.7
JS-2I	32	64	25.4	7/8"-14UNF	15.8
LS-2I	45	64	32	1 1/16"-12UNF	22.2
PS-2I	45	65	38	1 5/16"-12UNF	28.6

HS, JS, LS, PS-2J



SYMBOLS

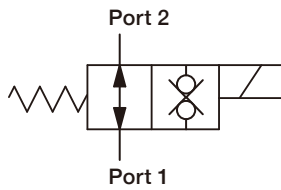

ORDER CODES

LS - **2J** - **16** - **D2**

① ② ③ ④

① ▶ Cavity	HS	T082
	JS	T102
	LS	T122
	PS	T162
② ▶ Type of Valve	2J	
	16	
③ ▶ Tube Diameter	16	
	16	
④ ▶ Power Source	A1	RAC110V
	A2	RAC220V
	D1	DC12V
	D2	DC24V

MODEL SPEC.

Model	Cavity	Tube Diameter	Capacity (l/min)	Max. Pressure (bar)	Installation Torque (Nm)	Weight (kg)
HS-2J	T082	16	28	250	39/51	0.41
JS-2J	T102	16	50	250	39/51	0.43
LS-2J	T122	16	100	250	39/51	0.56
PS-2J	T162	16	150	250	39/51	0.67

PERFORMANCE CURVES

Typical Pressure Drop

- energized,
Port 1 → Port 2
- de-energized,
Port 2 → Port 1

* 32cSt / 150 ssu oil at 40°C

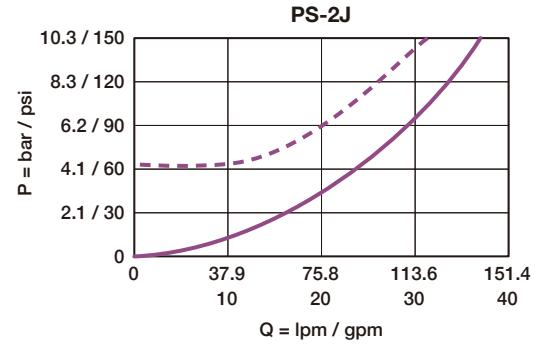
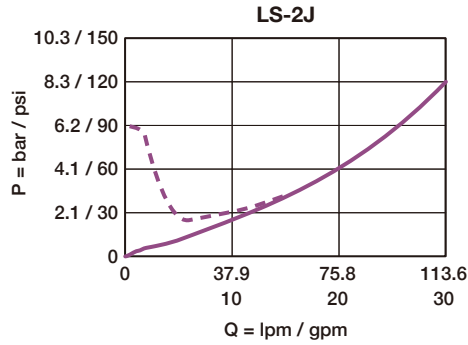
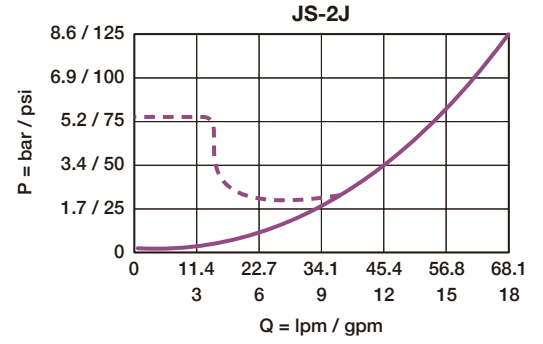
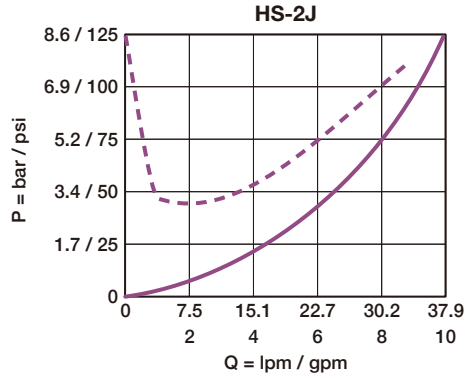

DIMENSION

(UNIT : mm)

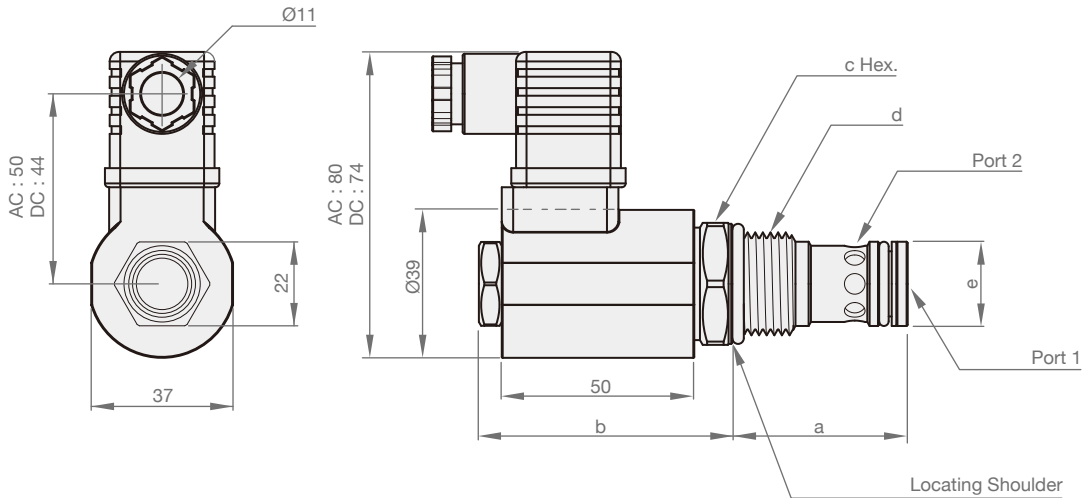

Model	a	b	c	d	e
HS-2A	28	64	22	3/4"-16UNF	12.7
JS-2A	32	64	25.4	7/8"-14UNF	15.8
LS-2A	45	64	32	1 1/16"-12UNF	22.2
PS-2A	45	65	38	1 5/16"-12UNF	28.6

HS-3A



SYMBOLS

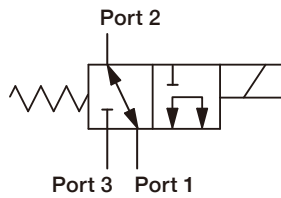

ORDER CODES

HS - **3A** - **16** - **D2**

1 2 3 4

1	▶ Cavity	HS	T082
		JS	T102
2	▶ Type of Valve	3A	
3	▶ Tube Diameter	16	
4	▶ Power Source	A1	RAC110V
		A2	RAC220V
		D1	DC12V
		D2	DC24V

MODEL SPEC.

Model	Cavity	Tube Diameter	Capacity (l/min)	Max. Pressure (bar)	Installation Torque (Nm)	Weight (kg)
HS-3A	T082	16	15	250	39/51	0.43
JS-3A	T102	16		250	39/51	

PERFORMANCE CURVES

► Typical Pressure Drop

- Port 1 → Port 3
- Port 1 → Port 2
- Port 2 → Port 1

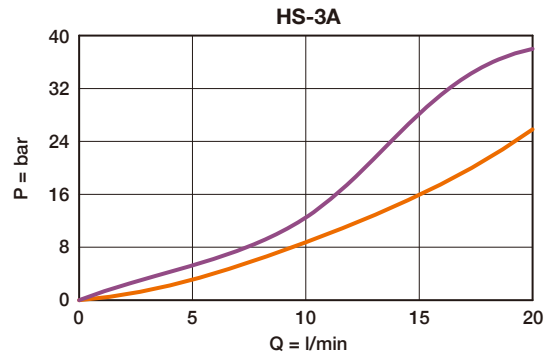

► Limits of Application

- Port 1 → Port 3
- Port 2 → Port 1
- Port 3 → Port 1
- Port 1 → Port 2

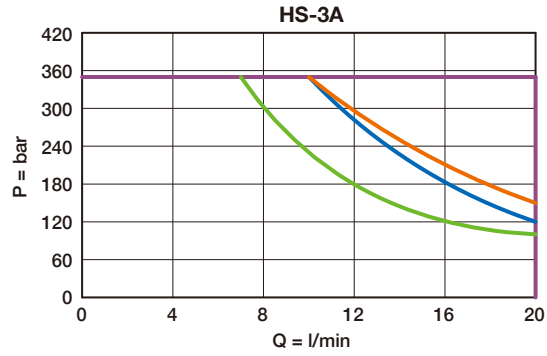

DIMENSION

(UNIT : mm)

► HS-3A

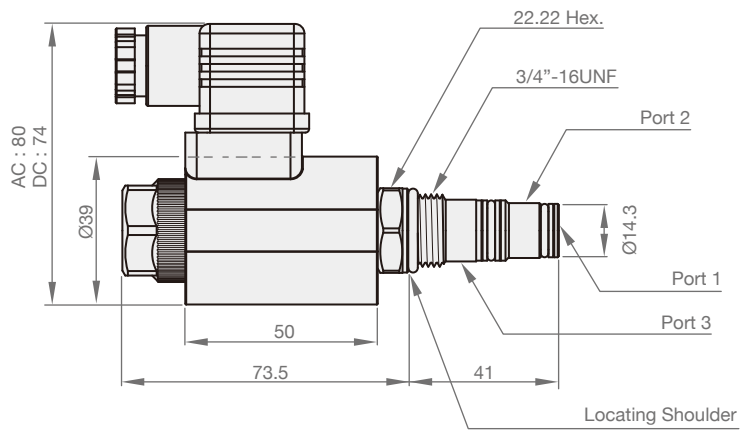
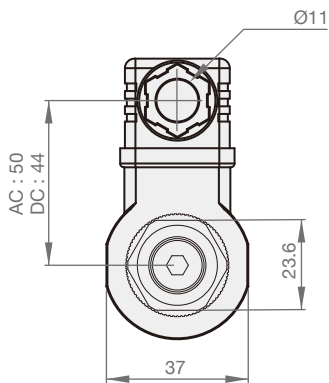

HS-3X



SYMBOLS

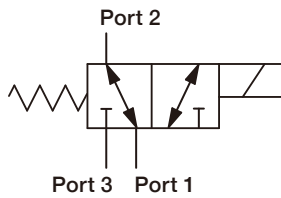

ORDER CODES

HS - **3X** - **16** - **A2**

1 2 3 4

1 ▶ Cavity	HS	T082
	JS	T102
2 ▶ Type of Valve	3X	
3 ▶ Tube Diameter	16	
4 ▶ Power Source	A1	RAC110V
	A2	RAC220V
	D1	DC12V
	D2	DC24V

MODEL SPEC.

Model	Cavity	Tube Diameter	Capacity (l/min)	Max. Pressure (bar)	Installation Torque (Nm)	Weight (kg)
HS-3X	T082	16	13	207	39/51	0.43
JS-3X	T102	16	38	207	39/51	0.52

PERFORMANCE CURVES

► Typical Pressure Drop

- Port 3 → Port 2
- Port 2 → Port 3
- Port 1 → Port 2
- Port 2 → Port 1

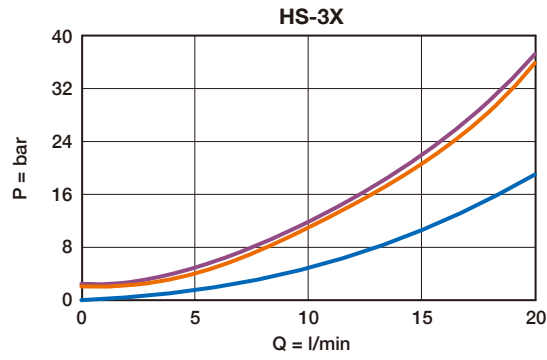

► Limits of Application

- Port 2 → Port 3
- Port 3 → Port 2
- Port 1 → Port 2
- Port 2 → Port 1

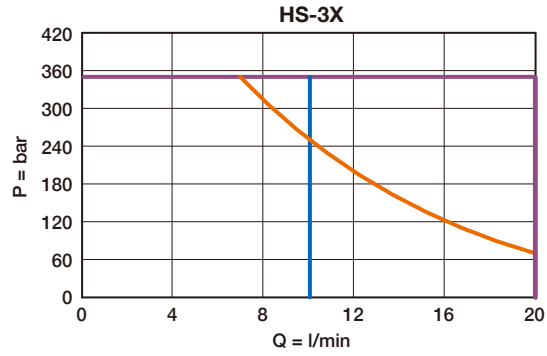

DIMENSION

(UNIT : mm)

► HS-3X

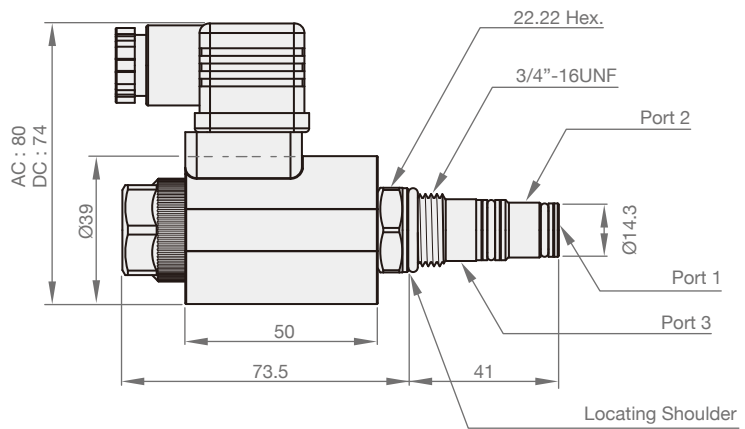
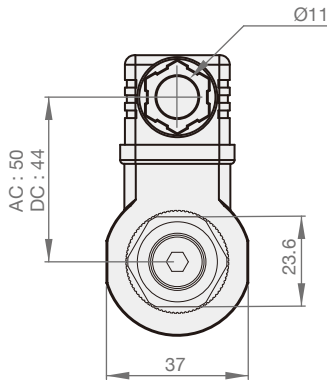

Cavities Tooling

2 Port Cavities Tooling

(UNIT : mm)

► T8A

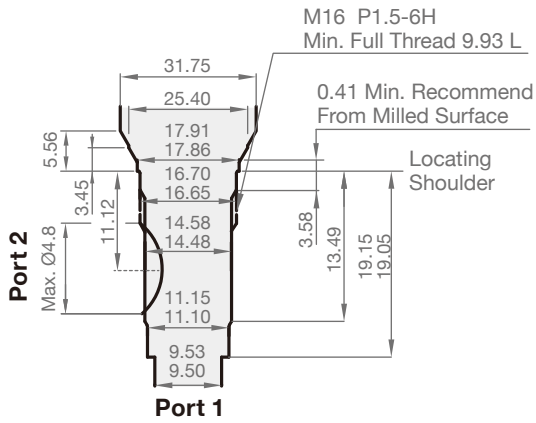

► T162A

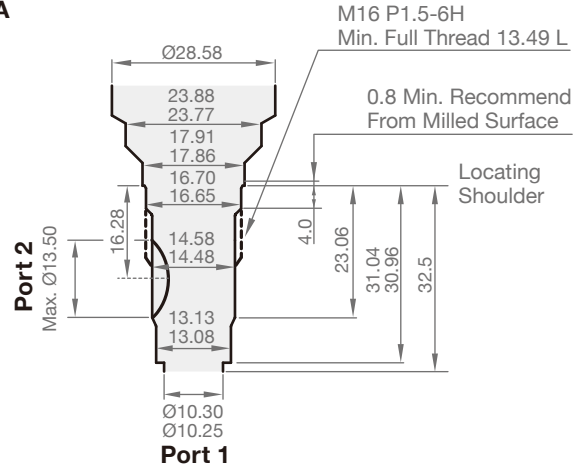

► T10A

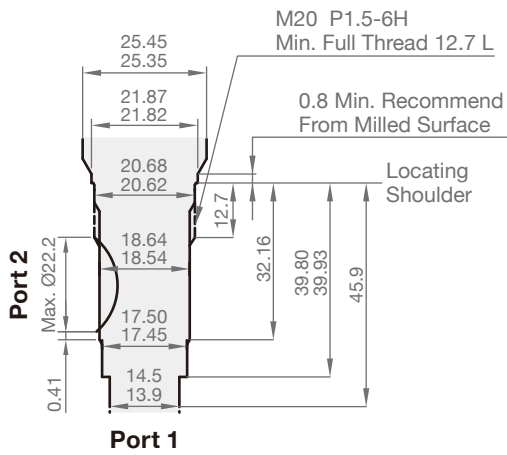

► T13A

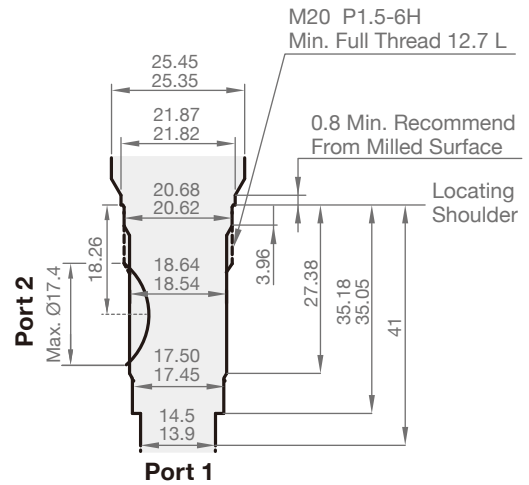

Size	Cavity
01	T8A, T162A
02	T10A, T13A
03	T3A, T5A
06	T16A
08	T18A

► T3A

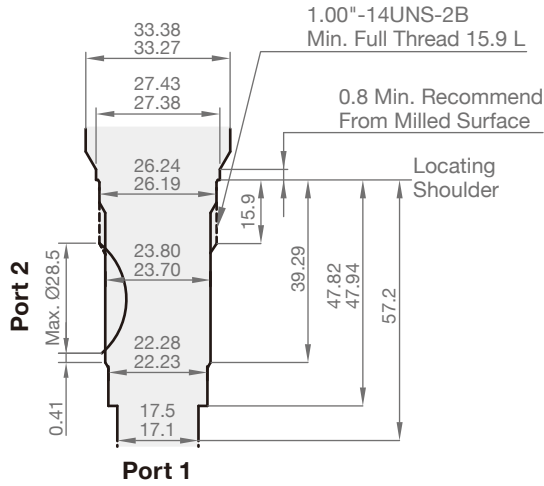

► T5A

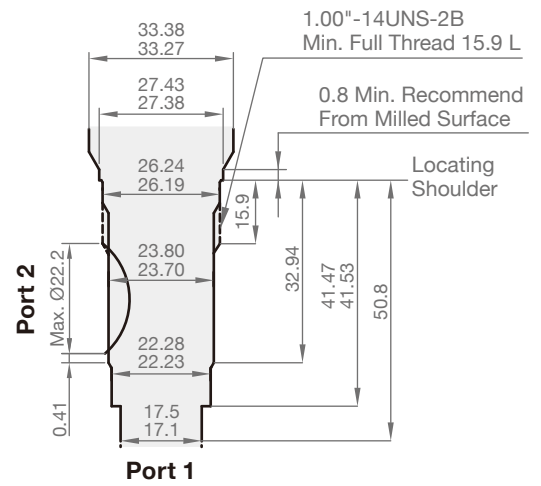

► T16A

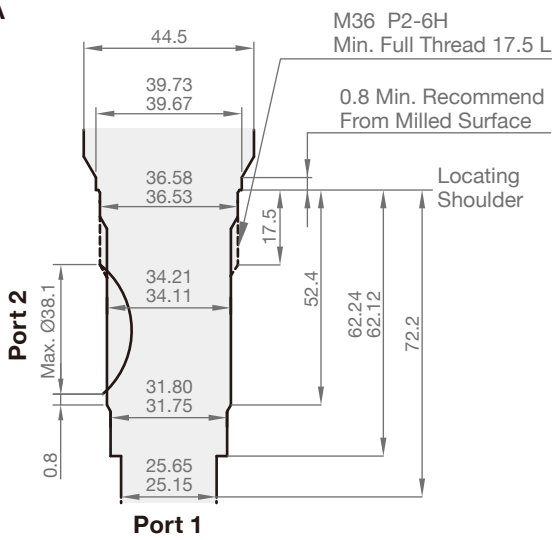

► T18A

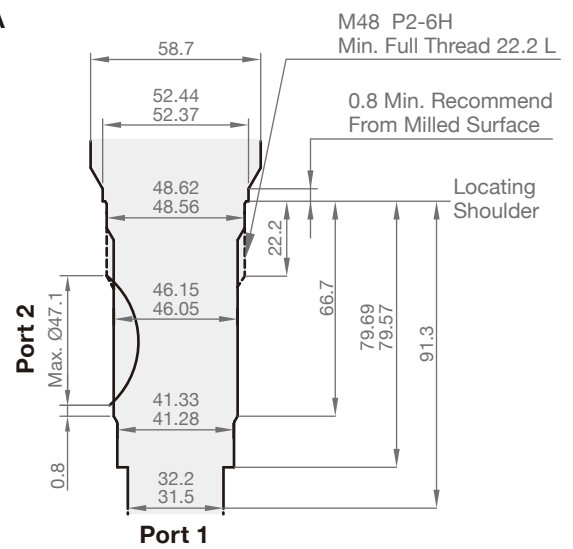

► T163A

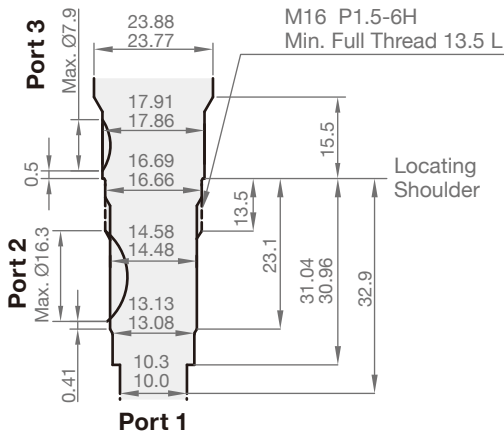

Size	Cavity
01	T163A
02	T11A
03	T2A
06	T17A
08	T19A

► T11A

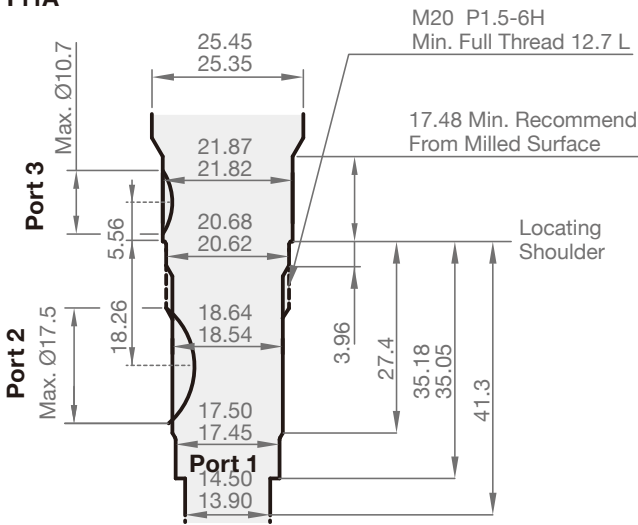

► T2A

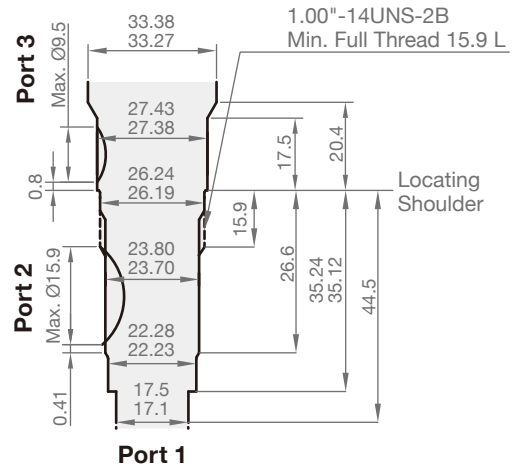

► T17A

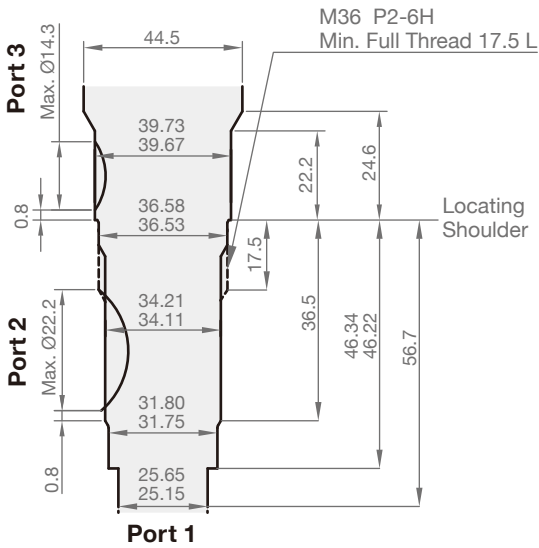

► T19A

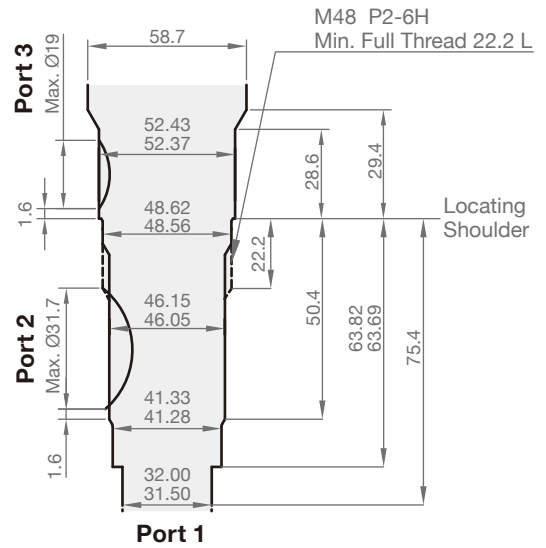

► T21A

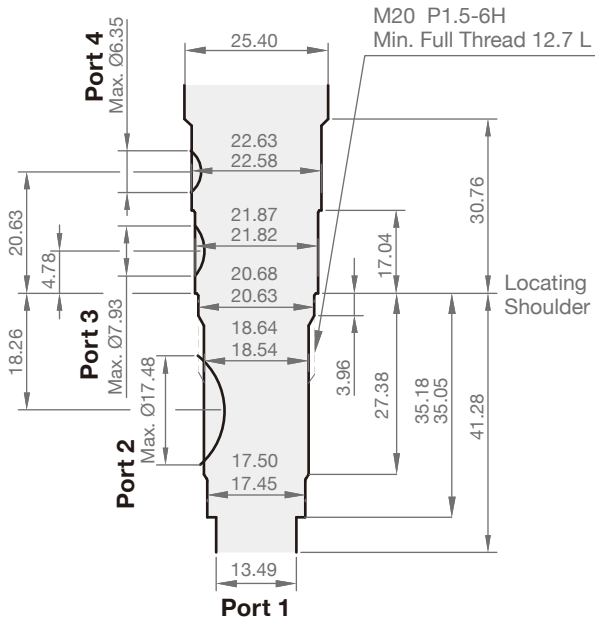

► T22A

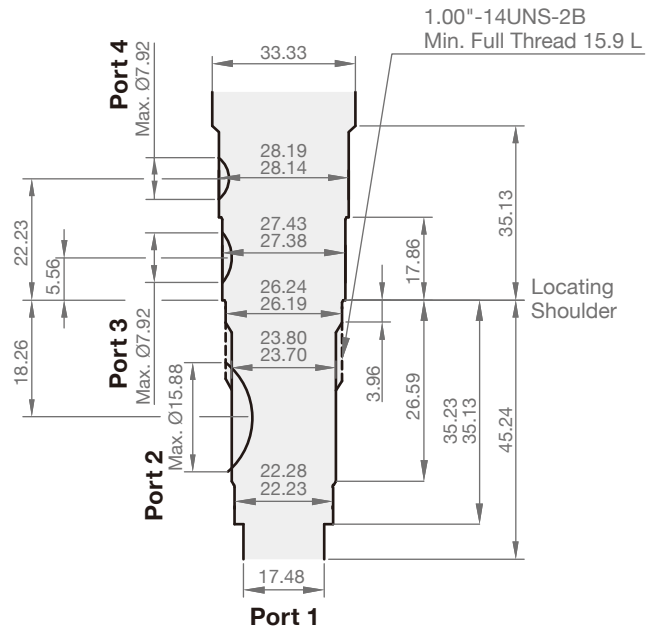

► T23A

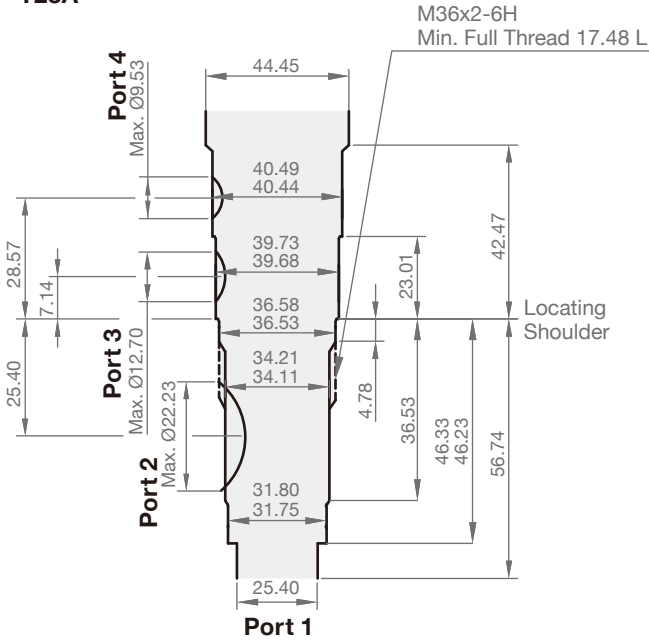

► T24A

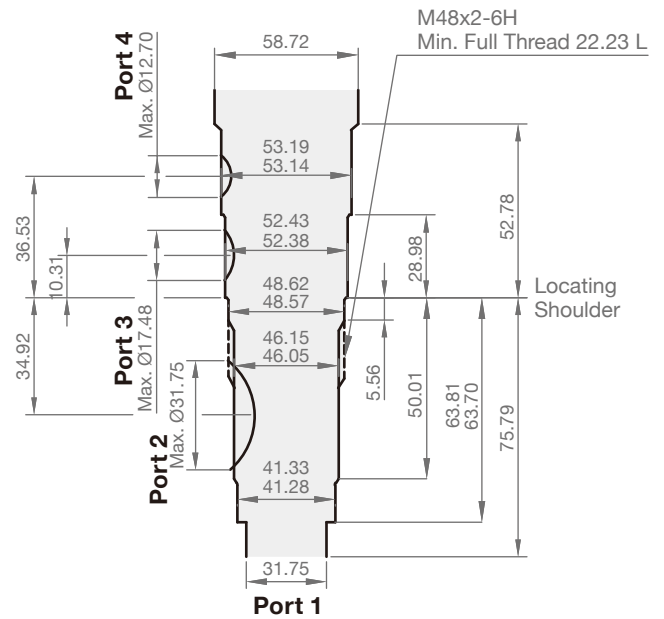

Cavities Tooling (SAE Cavity)

DIMENSION

(UNIT : mm)

► T82

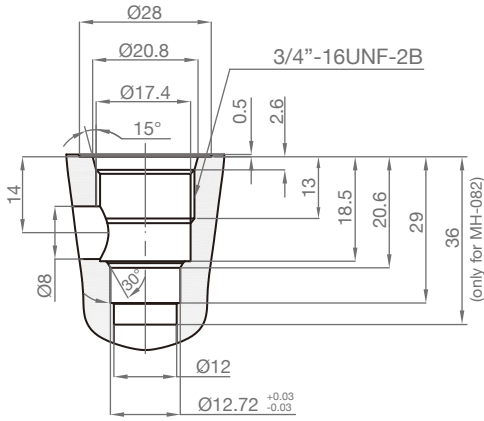

► T83

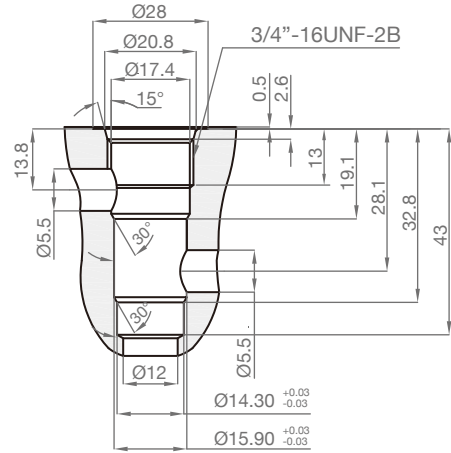

► T092

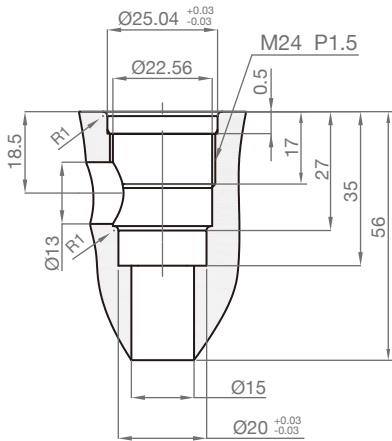

► T102

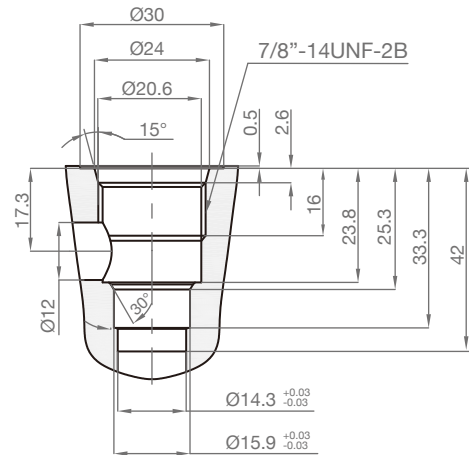

► T103

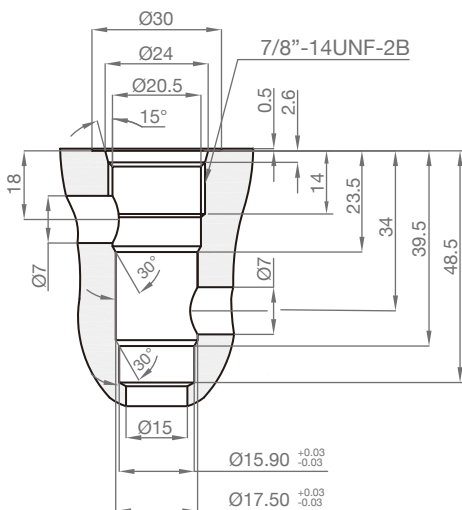

► T104

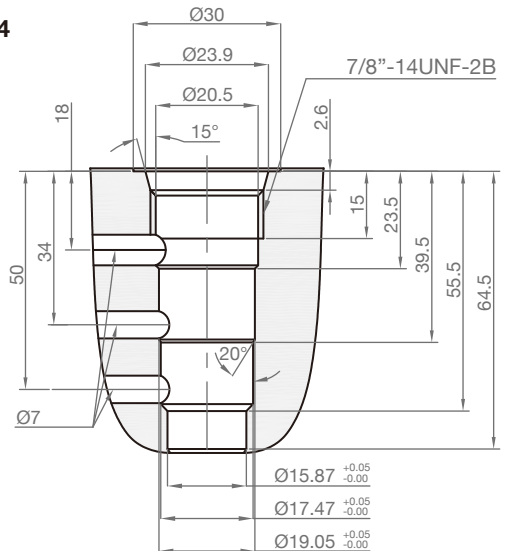

► T122

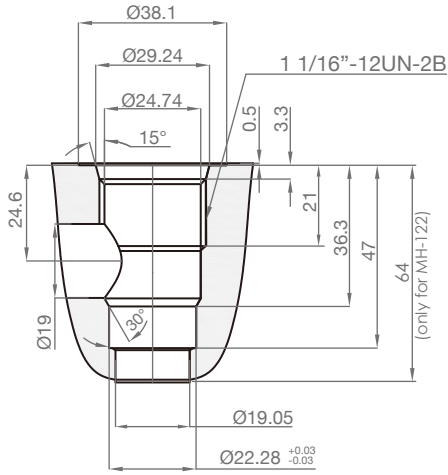

► T123

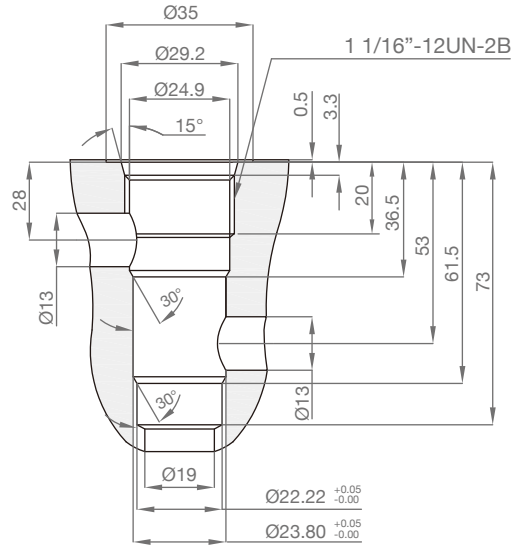

► T124

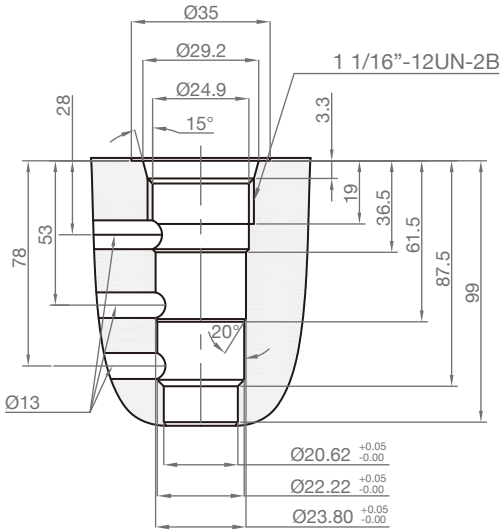

► T162

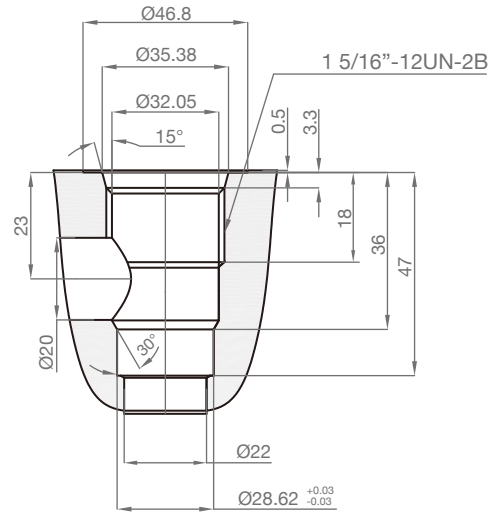

► T163

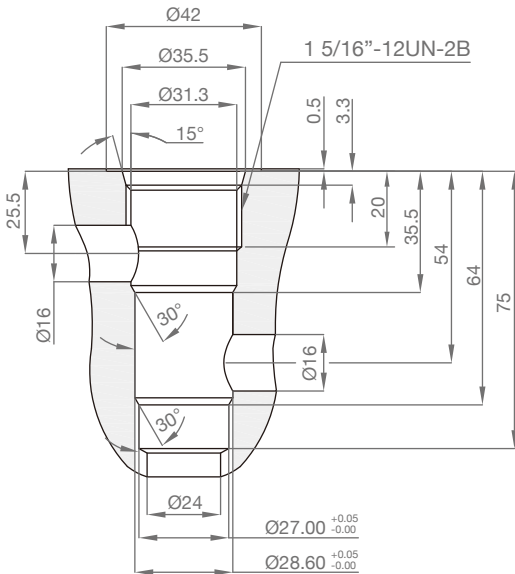

► T164

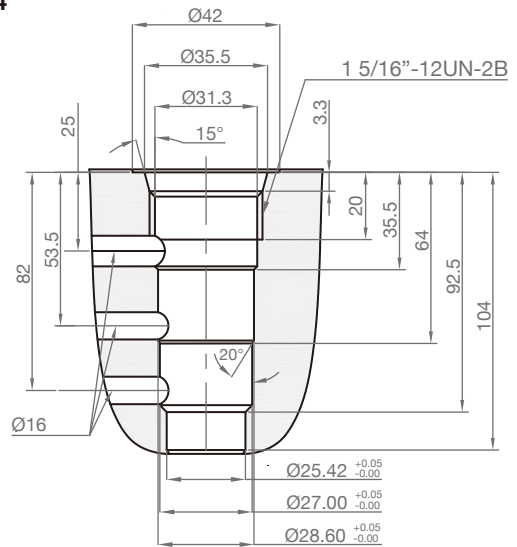

Steed Machinery Co., Ltd.

No. 28, Ruiguang St., South Dist.,
Taichung City 402006,
Taiwan
Tel : +886-4-2285-4867
Fax : +886-4-2285-2848
Email : info@steedmachinery.com.tw

more information
www.steedmachinery.com.tw

